



AC890/AC890PX Series

Modular AC Drives

1 - 1500 HP



ENGINEERING YOUR SUCCESS.



Parker Electromechanical and Drives Division Headquarters - Charlotte, NC

WARNING - USER RESPONSIBILITY

FAILURE OR IMPROPER SELECTION OR IMPROPER USE OF THE PRODUCTS DESCRIBED HEREIN OR RELATED ITEMS CAN CAUSE DEATH, PERSONAL INJURY AND PROPERTY DAMAGE.

This document and other information from Parker Hannifin Corporation, its subsidiaries and authorized distributors provide product or system options for further investigation by users having technical expertise.

The user, through its own analysis and testing, is solely responsible for making the final selection of the system and components and assuring that all performance, endurance, maintenance, safety and warning requirements of the application are met. The user must analyze all aspects of the application, follow applicable industry standards, and follow the information concerning the product in the current product catalog and in any other materials provided from Parker or its subsidiaries or authorized distributors.

To the extent that Parker or its subsidiaries or authorized distributors provide component or system options based upon data or specifications provided by the user, the user is responsible for determining that such data and specifications are suitable and sufficient for all applications and reasonably foreseeable uses of the components or systems.

OFFER OF SALE

The items described in this document are hereby offered for sale by Parker Hannifin Corporation, its subsidiaries or its authorized distributors. This offer and its acceptance by the provisions stated in the detailed 'Offer of Sale' which is available upon request.

Table of Contents

Topic		Power Range	Page
Introduction	Introduction to Parker Hannifin		4
AC890	AC890 modular systems drive	1 to 1500 HP	5
	Specifications		8
	Connection Diagram		9
	Active Front End - Regenerative Drives		10
	Dimensions		16
AC890PX	AC890PX modular high power drive	150 to 600 HP	17
	Specifications		20
	Part number key		23
Accessories and Options	Accessories and options AC890 and AC890PX	All	24
	Dynamic braking options AC890 and AC890PX		33
	Software tools		34
	EMC filters		35
	Input and output reactors		36
Motors	AC Inverter and Vector Duty Motors	2 to 64 Nm	37
	NX Servo Motors and TMW Torque Motors	1200 to 22,100 Nm	38

Parker Hannifin

The global leader in motion and control technologies and systems

Global Partnerships Global Support

Parker is committed to helping make our customers more productive and more profitable through our global offering of motion and control products and systems. In an increasingly competitive global economy, we seek to develop customer relationships as technology partnerships. Working closely with our customers, we can ensure the best selection of technologies to suit the needs of our customers' applications.



Electromechanical Technologies for High Dynamic Performance and Precision Motion

Parker electromechanical technologies form an important part of Parker's global motion and control offering. Electromechanical systems combine high performance speed and position control with the flexibility to adapt the systems to the rapidly changing needs of the industries we serve.



About Parker Hannifin Corporation

With annual sales of approximately \$13 billion in fiscal year 2015, Parker Hannifin is the world's leading diversified manufacturer of motion and control technologies and systems, providing precision-engineered solutions for a wide variety of mobile, industrial and aerospace markets. The company employs approximately 55,000 people in 50 countries around

the world. Parker has increased its annual dividends paid to shareholders for 59 consecutive fiscal years, among the top five longest-running dividend-increase records in the S&P 500 index. For more information, visit the company's website at www.parker.com, or its investor information website at www.phstock.com.

Modular Systems Drives

AC890 Systems Drive

1 HP - 1500HP

Description

The AC890 is a compact, modular systems-capable drive engineered to control speed and position of open-loop and closed-loop, single- or multi-motor AC induction or servo motor applications.

Features

The AC890 can be configured for 5 different modes of operation

Open-loop (volts/frequency) control

This mode is ideal for basic, single or multi-motor speed control.

Sensorless vector control

With its ultra high performance sensorless vector algorithm, the AC890 delivers a combination of both high torque and close speed regulation without the need for any speed measuring transducer.

Closed-loop vector control

Full closed-loop flux vector performance can be achieved with the AC890 by simply adding an encoder feedback 'technology box'. This provides 100% continuous full load standstill torque, plus a highly dynamic speed loop more than sufficient for the most demanding applications.

PMAC servo control

Allows the use of a PMAC motor like the TMW series, with feedback device.

Active front-end module for line regeneration

With this configuration, used in applications that require four quadrant or continuous braking operation, the regenerated energy is fed back into the grid with sinusoidal currents and unity power factor; a very low current harmonic content is achieved (THD less than 3%).

Compatible with a wide range of feedback options

The AC890 is compatible with any AC motor and virtually any speed/position feedback options. With this flexibility you may not even need to replace your existing AC motor to achieve high performance, saving you time and money.

- Incremental encoder
- EnDat 2.1 (SinCos) encoder
- Resolver

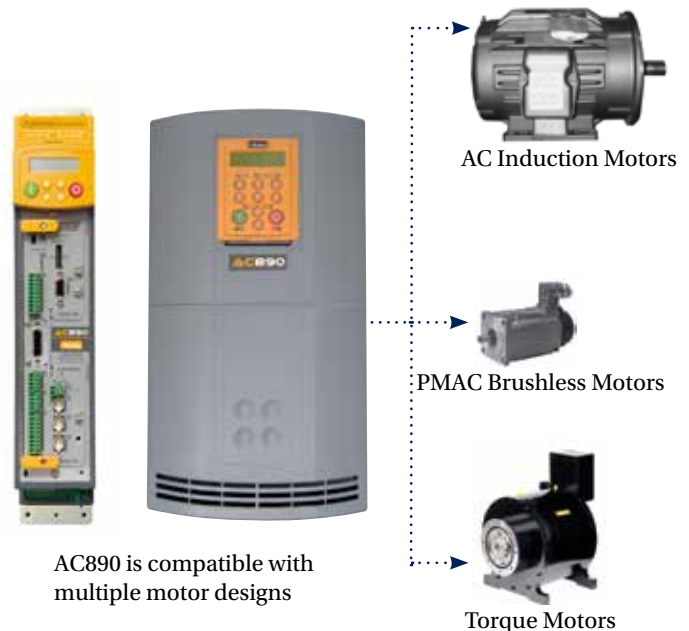

International Standards

Complies with :

- EN61800-3 (EMC) Directive
- CE Marked to EN50178 (Low Voltage) Directive
- Units listed in this catalog are UL Listed to US safety standard UL508C and cUL Listed to Canadian standard C22.2 #14 except where otherwise noted.

www.parker.com/ssdusa/ac890

Modular Systems Drives

AC890 Systems Drive

Features

Range of feedback options

- Incremental encoder
- EnDat® 2.1 (SinCos) encoder
- Resolver



Versatile communications

- Ethernet/IP
- Modbus/TCP
- CANopen
- Profibus-DP
- Profinet/IO
- EtherCAT
- RS485
- DeviceNet
- ControlNet
- FireWire IEEE 1394
- USB port

EtherNet/IP
CONFIDENCE TESTED

DeviceNet
CONFIDENCE TESTED

PROFIBUS

CANopen

ControlNet
CONFIDENCE TESTED

PROFINET

Ultra-fast control loops

- Torque loop: 62.5µs
- Speed loop: 62.5µs
- Position loop: 62.5µs

Serves the most demanding applications

Taking advantage of leading edge control algorithms running on a fast 150 Mhz microprocessor, the AC890 drive can achieve very high bandwidth control loops. This allows you to use the drive for the most demanding industrial applications e.g. printing, registration, cut-to-length, position synchronization, rotary shear, converting and slitting.

Benefits

Integrated safety functionality

The integrated Safe Torque Off (STO) functionality offers protection against unexpected motor start-up, in accordance to EN13849-1 PLE, SIL 3 as standard.

Minimal delay between fieldbus setpoints and the control loops

Designed to integrate in existing automation systems, the AC890 features high performance ports linked directly to the fast control loops of the drive. Minimum delay exists between your digital setpoint sent through a fieldbus and the control loops.

Replacement of analog solutions

Your existing analog setpoint-based solutions can be replaced by a digital fieldbus-based solution with minimum bandwidth loss.

Flexible feedback options

The AC890 offers system designers complete flexibility in their choice of feedback technology to best suit the needs of their application.

Open standards for protection of investment

The AC890 has been specifically designed to integrate seamlessly into your automation network. To connect to your PLC or fieldbus network you can simply choose from the wide range of communication technology boxes.

Two performance levels to suit all applications :

Advanced Performance

Motion control with position control, Motion control function blocks: incremental move, absolute move, move home Section Control : line drive master ramp, winder blocks (speed and current winder), PID process, sequencer, more...

High Performance

All "Advanced Performance" features PLUS: Library of pre-engineered application specific LINK VM function blocks such as: Shaftless printing, cut-to-length, advanced winding, advanced traversing and others.

Modular Systems Drives

AC890 Systems Drive

Space saving compact footprint thanks to modular design concept

Stand Alone version (SD)



The Complete Drive

The AC890SD series Stand Alone version provides a complete AC input to AC motor output drive, with keypad and display included. Perfect solution for single motor applications where line regeneration is not required.

Characteristics of the AC890SD include:

- Power output up to 1500 HP
- 208-500 VAC input supply
- Compatibility with all feedback and networking options
- Built-in dynamic brake switch with provision to add external braking resistor
- 24VDC control board supply for programming without power
- Torque and speed signal outputs
- USB programming port
- Operator keypad/display for programming, status, and diagnostics

Reduced dimensions, compact footprint

The AC890 has been designed to be compact and require the minimum possible cabinet space. Boasting the latest innovations in semiconductor cooling, the AC890 is a class leader in terms of its size.

Common Bus System (CS+CD)



Common Bus System

The AC890 is also available in a common bus platform, where multiple motor output drives (CD) are easily connected to a common DC bus supply (CS).

Characteristics of the common bus drive (AC890CD) :

- Power output to 150 HP in 5 frame sizes
- Power Supply : 320 to 705 VDC
- Compatibility with all feedback and networking options
- 24VDC control board supply for programming without power
- Torque and speed analog outputs
- USB programming port

Characteristics of the common bus supply module (AC890CS):

- Power output 25 to 135 HP
- Power Supply : 208-500 VAC
- Built-in dynamic braking unit (external braking resistor required)
- Operator display
- Up to 162A output per module

Removable terminal block connections for easier installation and maintenance



Fast connection of the common DC busbars



The control terminals are plug-in style, simplifying connection to the drive during installation and allowing a fast swap-out for maintenance purposes.

The Common DC bus also helps to keep the overall size of the system to a minimum. Simply open the bus terminal cover, connect the bus bars and close.

Modular Systems Drives

AC890 Systems Drive



Technical Specification

Power Supply	890CS : 208 - 500 VAC +/- 10 % 890CD : 320/560 - 705 VDC 890SD : 380 - 500 VAC +/- 10 % Frames E/F/G/H/J/K : 380 - 460 VAC +/- 10 %
Operating Temperature	0°-45°C (32°-113° F) - Frame B-F 0°-40°C (32°-104° F) - Frame G and above (derate by 2% per degree C up to 50°C maximum)
Altitude	Up to 1000m ASL (derate 1% per 100m to 2000m max)
Protection	IP20 (Frames G/H/J: IP00)
Humidity	Maximum 85% Non-Condensing
Analog Inputs	4; 12 bit, Configurable 2 x 0-10V, +/-10V, 0-20mA, 4-20mA and 2 x 0-10V, +/-10V (High resolution 15 bit plus sign analog input available with addition of 8903/AI option)
Analog Outputs	2; 12 bit, Configurable 0-10V, +/- 10V
Digital Inputs	7 ; Configurable 24VDC
Digital Output	2; Configurable 24VDC
Digital Relay Output	1; Configurable
Communications Options	EtherNet/IP, Modbus/TCP, CANopen, PROFIBUS, PROFINET, DeviceNet, ControlNet, FireWire, EtherCAT, Peer to peer, RS485/Modbus
Axis Synchronisation	Internally via Firewire IEEE1394
Overload	Constant Torque Ratings: 150% for 60 sec Variable Torque Ratings: 110% for 60 sec Servo Mode: 200% for 4 sec
Output Frequency	0-590 Hz - Volts/Hertz Mode 0-350 Hz - Closed Loop Vector Mode 0-120 Hz - Sensorless Vector Mode
Switching Frequency	Size B-D - 3 kHz (4 kHz or 8 kHz in servo mode) Size E - 3 kHz or 6 kHz Size F - 3 kHz Size G-H - 2.5 kHz Size J - 2 kHz Some exceptions may apply - see manual
Atmosphere	Non flammable, non corrosive and dust free

Safe Torque Off - STO

The AC890 features Safe Torque Off functionality as **standard**, offering users protection against unexpected motor start-up in accordance with EN18849-1 PL-e or SIL3. STO connections are made to X11 terminals per installation manual.

To ensure a high degree of safety, two independent STO control channels are implemented in hardware. The circuit is designed such that a fault in one control channel will not affect the other channel's ability to prevent the drive from starting, i.e. the STO function of the is tolerant to any single fault. It may not be tolerant to an accumulation of faults. This is in keeping with its declared safety ratings.

STO always overrides any attempt to start the drive. If one or both STO control inputs is requesting the STO function, the drive will not start, even if for example, the drive's software malfunctions and tries to cause the motor to turn. The STO function is implemented in hardware; it overrides all software activities. The only software involvement is to report STO status to the user via an MMI, serial communications link or user terminal on the AC890 control board as defined by the drive configuration.

Note: STO is an electronic inhibit intended for use during normal operation of the machine. It is not intended for use during machine maintenance, repair, replacement or other similar activities. For these activities recognized electrical power isolation devices and lock-out procedures must be used.

Conformal Coating

For environments that have dusty, humid or corrosive atmospheres, the AC890 can optionally be supplied with conformally coated circuit boards that improve the drives resistance to corrosion, thereby increasing reliability and service life. Environments that would typically benefit from conformal coating could include:

- Water and wastewater treatment plants
- Paper and pulp processing mills
- Steel mills
- Marine and offshore
- Outdoor cranes
- Wind, solar, and wave power generation (Grid tie configuration)
- Food and chemical processing plants

Modular Systems Drives

AC890 Systems Drive



Connection Diagram

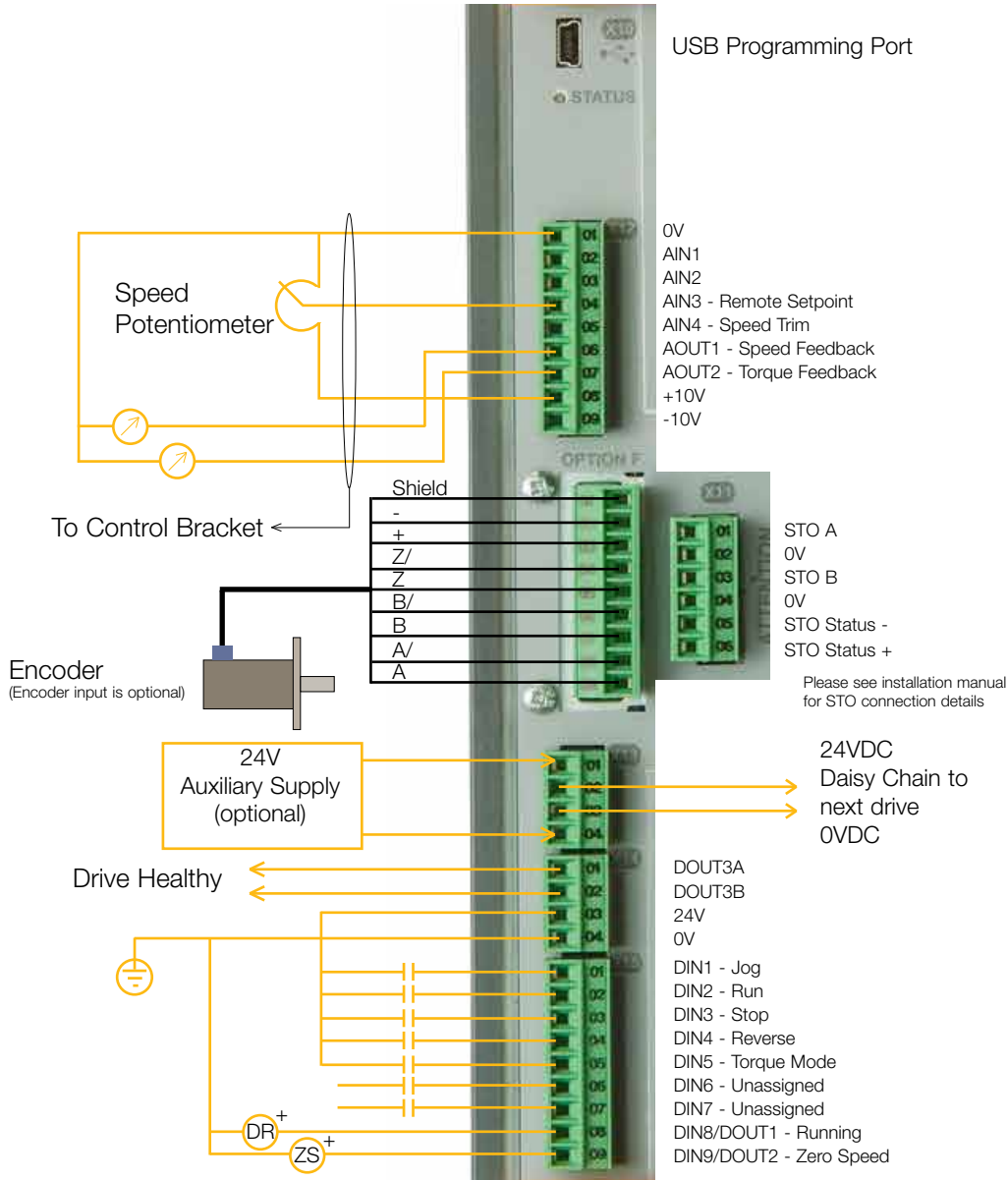

This diagram shows examples of some basic user connections to the Control Module. It is not intended to be a substitute for the installation manual which is provided with each drive and available for download on the website.

Modular Systems Drives

AC890 Systems Drive Active Front End



4 Quadrant active front-end power supply with regeneration to the grid

By specifying an AFE supply, AC890 common bus systems can be configured to feed energy back into the grid supply with sinusoidal currents and unity power factor; with very low levels of harmonic current distortion. Use the AFE with AC890CD modules for a complete system.

Required Parts (Provided with AFE package)

- Pre-charge circuit
- LCL Filter

FULLY BIDIRECTIONAL POWER FLOW

150% OVERLOAD FOR 60 SEC

SINUSOIDAL INPUT CURRENT

HARMONIC LEVELS MEET REQUIREMENTS OF IEEE 519

Note :

It is possible to use a larger separate active front-end module for higher power AC890 systems. In this case, several AC890's can be connected to the AFE using the AC890CA common bus adaptor.

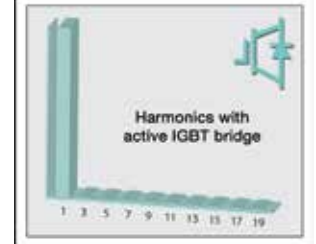
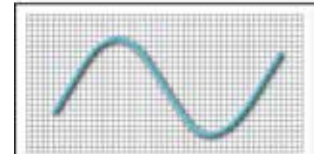
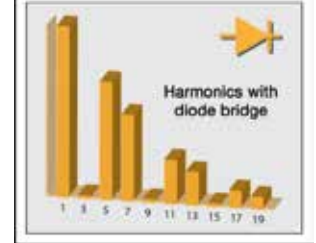
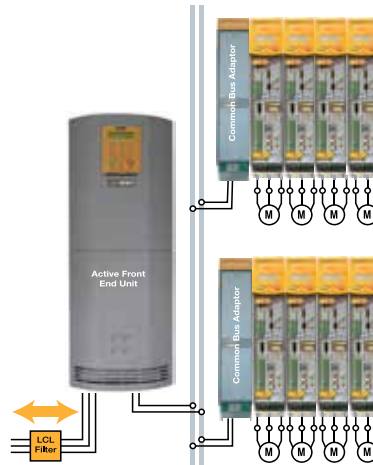
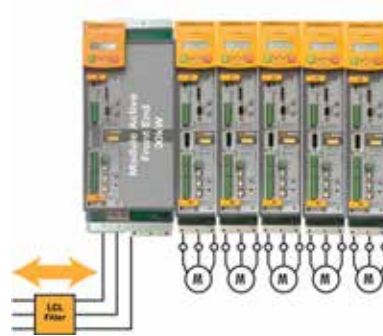
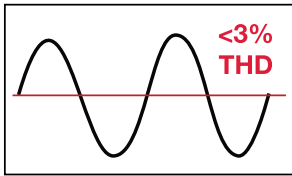

AFE Part Number	Sub-panel Part Number	Power (HP)	Current (A)	Notes
890CD/5/0016B/N/00/A/US	AFE-13-890	13	12	Sub-panel includes line synch module, pre-charge circuit, and LCL filter.
890CD/5/0030C/N/00/A/US	AFE-26-890	26	25	
890CD/5/0059D/N/00/A/US	AFE-45-890	45	45	
AFE-85-890	N/A	85	80	AFE includes AC890 drive configured as AFE, line synch module, pre-charge circuit, and LCL filter, provided on open panel
AFE-125-890		125	120	
AFE-167-890		167	160	
AFE-200-890		200	194	
AFE-300-890		300	284	AFE includes AC890 drive configured as AFE, line synch module, pre-charge circuit, and LCL filter, provided in enclosure.
AFE-350-890		350	325	
AFE-400-890		400	378	
AFE-500-890		500	468	

DC Power Supply Module

AC890CS Module

10 HP - 135 HP (40A - 200A)

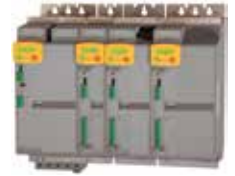

Description

Used in common bus systems, the AC890CS (Common Supply) module is able to provide DC bus voltage to one or more AC890CD units. Inter-connecting busbar is available from Parker. This modularity provides significant space saving in the enclosure. For 12 pulse or 18 pulse input, multiple CS modules may be used. (See page 55 for details on alternate input power configurations.)

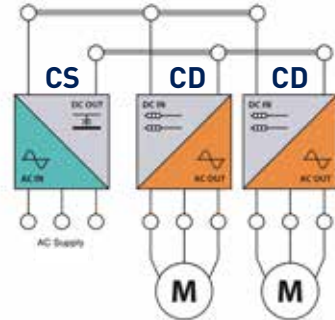

DC Power Supply

Use with AC890CD for a common bus system

208-500VAC Input

Built-in dynamic braking unit

DC bus power output terminals

Operator display for diagnostics

CS Module Includes:

“Drive Healthy” contact

24VDC auxiliary supply (optional)

HMI Interface

Power supply selector

Configurable analog outputs

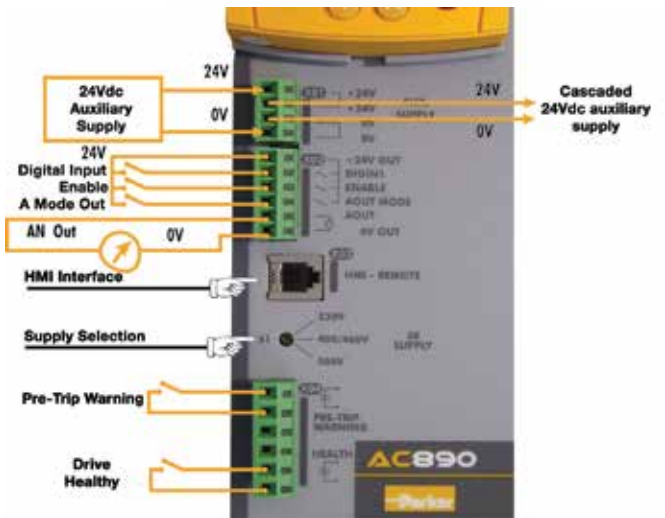

Electrical Characteristics - AC890CS Drives

Part Number	Frame	Input voltage (VAC)	Power (HP)	Power (kW)	AC input current (A)	DC output current (A)
890CS/5/0032B/B/00/N/EN	B	230	10	7.5	32	40
		400/460	25	15		
890CS/5/0054B/B/00/N/EN	B	230	20	15	54	65
		400/460	45	30		
890CS/5/0108D/B/00/N/EN	D	230	40	30	108	135
		400/460	90	60		
890CS/5/0162D/B/00/N/EN	D	230	60	45	162	200
		400/460	135	90		

kW power ratings correspond to 400 VAC input

Note: For increased power, additional units can be connected in parallel.

For further details, contact our technical support department

Modular AC Systems Drives

AC890CD Series Systems Drive

1 HP - 150 HP (1.5A - 180A)



Description

Used in common bus systems, the AC890CD (Common Drive) module accepts DC input from an AC890CS unit. Multiple CD units may be connected to a single CS. Interconnecting busbar is available from Parker. This modularity provides significant space saving in the enclosure. Typical applications include printing, converting, or other continuous web processes.

DC Input

Power Supply 320, 650, 705VDC

Use with AC890CS for a common bus system

Operator display supplied as standard

Common options as AC890SD (See page 66)

Electrical Characteristics - AC890CD Drive

Part Number	Frame	CS Module Voltage	Constant Torque			Variable Torque			Servo		Features
			Power (HP/kW)	Output Current (A)		Power (HP/kW)	Output Current (A)		Output Current (A)		
				208 or 380	230 or 460		208 or 380	230 or 460	208 or 380	230 or 460	
890CD/2/0003B/N/00/A/US	B	208/230	0.75/.55	3	3	0.75/.55	3	3	2.2	2.2	Internal Fusing
890CD/2/0005B/N/00/A/US		208/230	1.5/1.1	5.5	5.5	1.5/1.1	5.5	5.5	4	4	Internal Fusing
890CD/2/0007B/N/00/A/US		208/230	2/1.5	7	7	2/1.5	7	7	6	6	Internal Fusing
890CD/2/0011B/N/00/A/US		208/230	3/2.2	11	11	3/2.2	11	11	8	8	Internal Fusing
890CD/2/0016B/N/00/A/US		208/230	5/4	16.5	16.5	5/4	16.5	16.5	12	12	Internal Fusing
890CD/2/0024C/N/00/A/US	C	208/230	7.5/5.5	24	24	7.5/5.5	24	24	24	24	Internal Fusing
890CD/2/0030C/N/00/A/US		208/230	10/7.5	30	30	10/7.5	30	30	30	30	Internal Fusing
890CD/5/0002B/N/00/A/US	B	380/500	1/.55	2	2	1/0.55	2	2	1.5	1.5	Internal Fusing
890CD/5/0003B/N/00/A/US		380/500	1.5/1.1	3.5	3.5	1.5/1.1	3.5	3.5	2.5	2.5	Internal Fusing
890CD/5/0004B/N/00/A/US		380/500	2/1.5	4.5	4.5	2/1.5	4.5	4.5	3.5	3.5	Internal Fusing
890CD/5/0006B/N/00/A/US		380/500	3/2.2	5	6	3/2.2	5	5	4	4	Internal Fusing
890CD/5/0010B/N/00/A/US		380/500	5/4	8	10	5/4	8	8	6	6	Internal Fusing
890CD/5/0012B/N/00/A/US		380/500	7.5/5.5	12	12	7.5/5.5	12	12	9	9	Internal Fusing
890CD/5/0016B/N/00/A/US		380/500	10/7.5	14	16	10/7.5	14	16	10	12	Internal Fusing
890CD/5/0024C/N/00/A/US	C	380/500	15/11	24	24	15/11	24	24	20	20	Internal Fusing
890CD/5/0030C/N/00/A/US		380/500	20/15	27	30	20/15	27	30	22	25	Internal Fusing
890CD/5/0039D/N/00/A/US	D	380/500	25/18.5	35	39	25/18.5	35	39	29	35	Internal Fusing
890CD/5/0045D/N/00/A/US		380/500	30/22	40	45	30/22	40	45	34	38	Internal Fusing
890CD/5/0059D/N/00/A/US		380/500	40/30	52	59	40/30	52	59	45	50	Internal Fusing
890CD/4/0073E/N/00/A/US	E	380/500	50/37	73	73	60/45	87	87	73	73	Requires DC Fusing
890CD/4/0087E/N/00/A/US		380/500	60/45	87	87	75/55	105	105	87	87	Requires DC Fusing
890CD/4/0105F/N/1F/A/US	F	500/380	75/55	100	105	100/75	125	145	74	78	Requires DC Fusing
890CD/4/0145F/N/1F/A/US		500/380	100/75	130	145	125/90	156	165	99	110	Requires DC Fusing
890CD/4/0156F/N/1F/A/US*		500/380	125/90	156	180	150/110	180	205	117	135	Requires DC Fusing
890CD/4/0180F/N/1F/A/US*		500/380	150/90	180	180	N/A	N/A	N/A	135	135	Requires DC Fusing

Note : The AC890 can be provided as Advanced Performance (Per table above) or High Performance by changing "A" in part number to "H".
* 890CD/4/0156F/... and 890CD/4/0180F/... are not UL or cUL listed

Note : For higher powers, refer to AC890SD series supplied from a DC bus.
Servo current ratings assume 4kHz switching frequency.
Servo overload ratings: Frame B-D - 200% for 4 sec., Frame E-F - 150% for 60 sec.



Modular AC Systems Drives

AC890SD Series Systems Drive

0.75 HP - 1500 HP



Description

The AC890SD (Standalone) drives are independent modules with integrated three-phase AC supply inputs. With its wide range of sizes available, the AC890SD is suitable for every type of application from a small machine to a large industrial high power process line. For variable torque loads like fans, blowers, and most pumps, economical “VT” ratings are offered for Frame E and larger.

AC Input or DC common bus

Built-in dynamic braking module

Operator display provided as standard

Common options as AC890CD (See page 66)

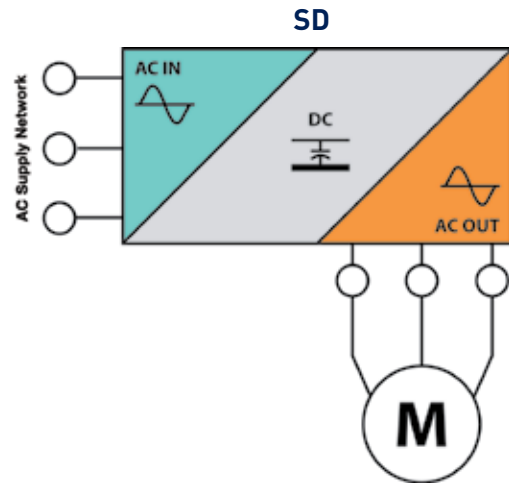

Electrical Characteristics - AC890SD Drive - 230V

Part Number	Frame	Input Voltage (VAC)	Power CT or VT (HP/kW)	CT or VT Output Current (A)	Servo Output Current (A)
890SD/2/0003B/B/00/A/US	B	230	1/.55	3	2.2
890SD/2/0005B/B/00/A/US			1.5/1.1	5.5	4
890SD/2/0007B/B/00/A/US			2/1.5	7	6
890SD/2/0011B/B/00/A/US			3/2.2	11	8
890SD/2/0016B/B/00/A/US			5/4	16.5	12
890SD/2/0024C/B/00/A/US	C	230	7.5/5.5	24	24
890SD/2/0030C/B/00/A/US			10/7.5	30	30

Note : All SD units above include brake module.

Permitted overload : 150% for 60 sec in vector mode - 200% for 4 sec in servo mode.

Electrical Characteristics - AC890SD drive (contd.)

Part Number	Frame	Input voltage (VAC)	Constant Torque			Variable Torque			Servo		Inductance
			Power (HP/kW)	Output Current (A)		Power (HP/kW)	Output Current (A)		Output Current (A)		
				400V	460V		400V	460V	400V	460V	
890SD/5/0002B/B/00/A/US	B	380-460	1/.55	2	2	1/.55	2	2	1.5	1.5	
890SD/5/0003B/B/00/A/US			1.5/1.1	3.5	3.5	1.5/1.1	3.5	3.5	2.5	2.5	
890SD/5/0004B/B/00/A/US			2/1.5	4.5	4.5	2/1.5	4.5	4.5	3.5	3.5	
890SD/5/0006B/B/00/A/US			3/2.2	5	5	3/2.2	5	5	4	4	
890SD/5/0010B/B/00/A/US			5/4	8	8	5/4	8	8	6	6	
890SD/5/0012B/B/00/A/US			7.5/5.5	12	12	7.5/5.5	12	12	9	9	
890SD/5/0016B/B/00/A/US			10/7.5	14	16	10/7.5	14	16	10	12	
890SD/5/0024C/B/00/A/US	C	380-500	15/11	24	24	15/11	24	24	20	20	
890SD/5/0030C/B/00/A/US			20/15	27	30	20/15	27	30	22	25	
890SD/5/0039D/B/00/A/US	D	380-500	25/18.5	35	39	25/18.5	35	39	29	35	
890SD/5/0045D/B/00/A/US			30/22	40	45	30/22	40	45	34	38	
890SD/5/0059D/B/00/A/US			40/30	52	59	40/30	52	59	45	50	
890SD/4/0073E/B/00/A/US	E	380-460	50/37	73	73	60/45	87	87	73	73	
890SD/4/0087E/B/00/A/US			60/45	87	87	75/55	105	105	87	87	
890SD/4/0105F/B/1F/A/US	F	380-460	75/55	100	105	100/75	125	145	74	78	
890SD/4/0145F/B/1F/A/US			100/75	130	145	125/90	156	165	99	110	
890SD/4/0180F/B/1F/A/US			150/110	180	180	150/90	180	205	135	135	
890SD/4/0250G/N/1F/A/US	G	380-460	200/132	250	250	250/150	302	302	171	171	
890SD/4/0250G/B/1F/A/US			200/132	250	250	250/150	302	302	171	171	
890SD/4/0361G/N/1F/A/US			300/180	361	361	350/220	420	420	253	253	
890SD/4/0361G/B/1F/A/US			300/180	361	361	350/220	420	420	253	253	
890SD/4/0420H/N/1F/A/US	H	380-460	350/220	420	420	400/250	480	480	300	300	
890SD/4/0420H/B/1F/A/US			350/220	420	420	400/250	480	480	300	300	
890SD/4/0520H/N/1F/A/US			450/280	520	520	500/315	590	590	368	368	
890SD/4/0520H/B/1F/A/US			450/280	520	520	500/315	590	590	368	368	
890SD/4/0590J/N/1F/A/US	J	380-460	500/315	590	590	550/355	650	650	411	411	
890SD/4/0590J/B/1F/A/US			500/315	590	590	550/355	650	650	411	411	
890SD/4/0685K/ * /1F/A/US	K (2xG) *	380-460	600/355	685	685	700/400	798	798	N/A		
890SD/4/0798K/ * /1F/A/US	K (2xH) *		700/400	798	798	800/475	912	912	N/A		
890SD/4/0988K/ * /1F/A/US	K (2xH) *		800/500	988	988	900/600	1120	1120	N/A		
890SD/5/1028K/ * /1F/A/US	K (3xG) **		900/550	1028	1028	1000/630	1197	1197	N/A		
890SD/5/1120K/ * /1F/A/US	K (2xJ) *		1000/600	1120	1120	1100/650	1235	1235	N/A		
890SD/5/1197K/ * /1F/A/US	K (3xH) **		1000/630	1197	1197	1200/750	1368	1368	N/A		
890SD/5/1482K/ * /1F/A/US	K (3xH) **		1300/800	1482	1482	1500/900	1681	1681	N/A		
890SD/5/1681K/ * /1F/A/US	K (3xJ) **		1500/900	1681	1681	1600/1000	1852	1852	N/A		

Kilowatt ratings correspond to 400 VAC input.
Specify VT or CT when ordering K frame units.
*12-Pulse Input Optional
**18-Pulse Input Optional

Permitted overload : 150% for 60 sec in vector mode
Servo current ratings assume 4kHz switching frequency.
Servo overload ratings: Frame B-D - 200% for 4 sec., Frame E-F - 150% for 60 sec.



Modular AC Systems Drives

AC890 Alternative Input Power Configurations

0.75 HP - 1500 HP

The modular design of the AC890 makes it easy to connect parallel input (CS) modules for multi-phase configurations. By using 12-pulse or 18-pulse configurations, harmful line harmonics can be greatly reduced. Or, for the ultimate in harmonic abatement, an Active Front End (AFE) may be selected. (See page 50 for details on AFE units.)

The typical AC drive has six rectifiers in a three phase bridge configuration, and is commonly referred to as a "6-pulse" configuration. A 12-pulse drive configuration contains two sets of six rectifiers, an 18-pulse configuration, three sets of six rectifiers and so on. If the AC power connected to each set of rectifiers is "phase shifted", then some of the harmonics produced by one set of rectifiers will be opposite in polarity from the harmonics produced by the other set of rectifiers. The two (or three) wave forms effectively cancel each other out. To provide the phase shifted AC power, a special transformer with multiple secondary windings is specified.

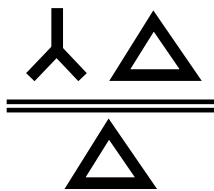

12 Pulse Transformer Configuration

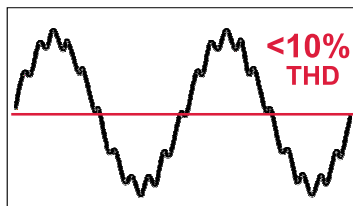

Input Current Waveform

12 pulse connection (option)	CS Modules Required	2
	Harmonics	Under 10% THD
	Input Transformer	User supplied - Delta primary, Wye and Delta secondaries, 30 degree phase shift.

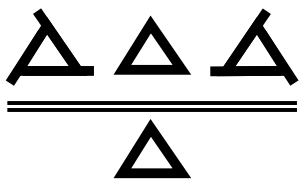

18 Pulse Transformer Configuration

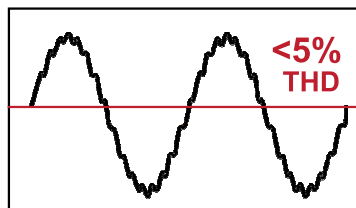

Input Current Waveform

18 pulse connection (option)	CS Modules Required	3
	Harmonics	Under 5% THD
	Input Transformer	User supplied - Delta primary, three secondaries, 20 degree phase shift.

For installations that require ultra low harmonics, with THD under 3%, consider an Active Front End (AFE) as described on page 50.

Dimensions

AC890 Series Systems Drives

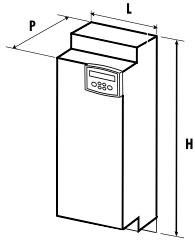

Frames B/C/D

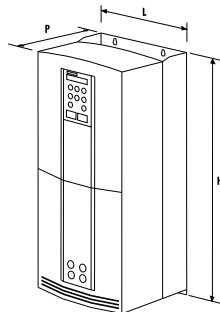

Frames E/F

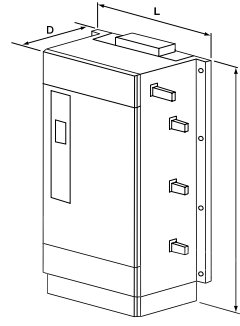

Frames G/H/J

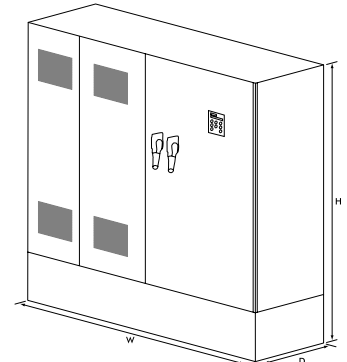

Frame K

Dimensions and Weights

Model	H (in/mm)	W (in/mm)	D (in/mm)	Weight (lb/kg)			
				AC890CS	AC890CD	AC890SD	
AC890 Frame B	17.0/433	2.85/72.4	10.16/258	7.7/3.5	11.0/5	13.2/6	
AC890 Frame C		4.57/116		N/A	14.6/6.6	16.8/7.6	
AC890 Frame D		6.30/160		19.2/8.7	26.7/12.1	28.9/13.1	
AC890 Frame E	26.3/668	10.12/257	12.28/312	N/A	71.7/32.5	73.9/33.5	
AC890 Frame F	28.35/720		13.98/355				90.4/41
AC890 Frame G	41.0/1042	17.95/456	18.31/465				N/A
AC890 Frame H	46.34/1177	22.52/572		304/138			
AC890 Frame J	50.71/1288	26.57/675		388/176			
Frame K - 685A, 798A, 988A, and 1120A ratings	79/2007	128/3251	24/610	N/A	N/A	N/A	
Frame K - 1028A, 1197A, 1482A, and 1681A ratings		176/4470					
AFE-13/26/45-890 (sub-panel)	22/559	18/457		N/A	N/A	N/A	
AFE-85/125/167-890	46/1168	34/864		N/A	N/A	N/A	
AFE-200/300/350/400/500-890	79/2007	47/1194	24/610	N/A	N/A	N/A	

High Power Modular AC Drives

AC890PX Series

150 - 600 HP/110 - 400kW

Description

The AC890PX is a high power standalone modular enclosed drive designed for industrial applications. It is especially suited to retrofit applications where a complete standard enclosed drive system is required. It is particularly suited to the following applications:

- Energy-saving pump and fan applications
- Extruders
- Hoists and Cranes
- Mixers and Centrifuges
- Engine Dynamometers

Models Available:
400 VAC
460 VAC
575 VAC
690 VAC

Features

Suitable for use with all types of AC motor

The AC890PX can control all types of AC motor:

- Induction motors
- PMAC servo motors
- Torque Motors

Operation with or without feedback

The drive can be configured for the following operating modes:

- Volts/Hertz speed control
- Sensorless Vector speed control
- Full Flux Vector speed control
- PMAC Servo motor speed/position control

Compatible with a wide range of feedback options

Thanks to a range of optional feedback cards, the AC890PX works with all types of popular feedback systems:

- Incremental encoder
- Resolver
- SinCos (Endat 2.1) encoder
- Absolute encoder EnDat

Conforming to international standards

Suitable for supply voltages of 380Vac to 690Vac, the AC890PX can be connected to different supply networks around the world without any additional equipment. Meeting the requirements of key international standards, the AC890PX is supported around the world through the Parker Drives support network.



High Power Modular AC Drive

AC890PX Series

150 - 600 HP/110 - 400kW

Features

Ultra-Compact Drive

The extremely compact footprint of the AC890PX is unmatched in the high power AC drives market. Within its small frame it integrates all of the standard equipment necessary for your installation: line reactor, disconnect switch, fuses and second environment line filter (compliant to EN 61800-3), and more. Configuration and start-up of the drive can be performed using the operator keypad in a matter of minutes or from your laptop using the DSELite configuration software.

- **STANDARD 3% Line Reactor**
- **STANDARD AC Disconnect**
- **STANDARD Line Fuses**
- **STANDARD Dynamic Braking**

Low-maintenance ensures maximum machine up-time and productivity

Thanks to a plug in design, the individual “PowerPak” phase modules of the AC890PX can be replaced in just minutes by any technician, even a non-specialist. These lightweight, ship anywhere modules help to reduce machine downtime and lost productivity in the event of a fault occurring. And each phase module has its own on-board diagnostics to make troubleshooting a snap.



PowerPak Phase Module – Front View



PowerPak Phase Module - Rear View

Total flexibility for easy factory integration

To facilitate maximum integration into the factory or existing buildings the AC890PX is available in a number of different variants :

- Top or bottom cable entry/exit to suit existing wiring arrangements
- 12 or 18 pulse configuration
- Active Front-End with negligible harmonic distortion
- Integrated contactors, fuses, chokes etc.

Note : Certain variants require an additional enclosure bay.

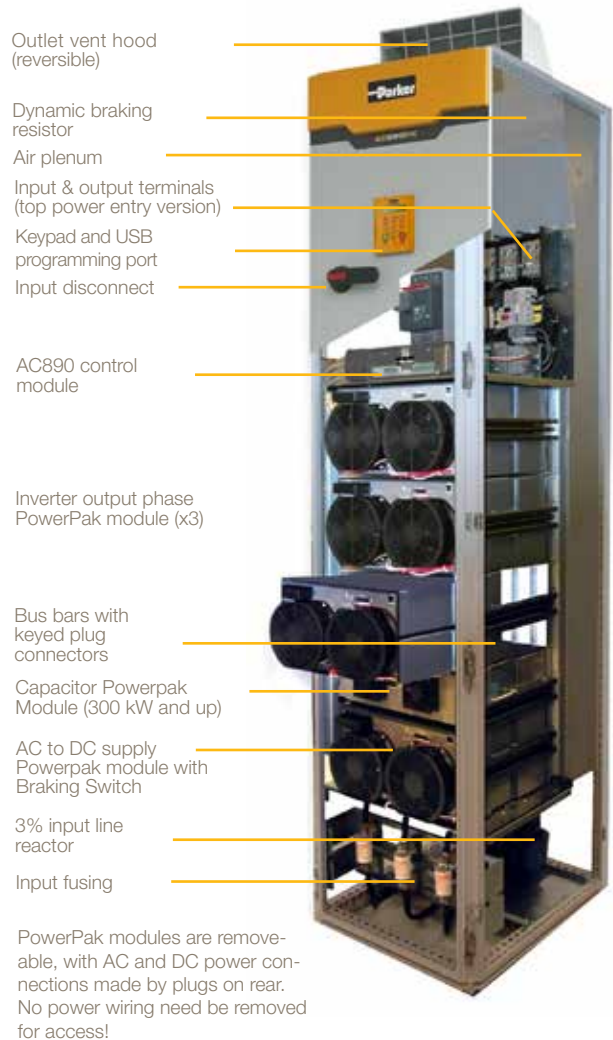

Top Cable entry/exit

Bottom Cable entry/exit



High Power Modular AC Drive

AC890PX Series

150 - 600 HP/110 - 400kW

Alternative Input Power Configurations



Active Front-End (AFE) Version - Energy regeneration with low harmonic distortion

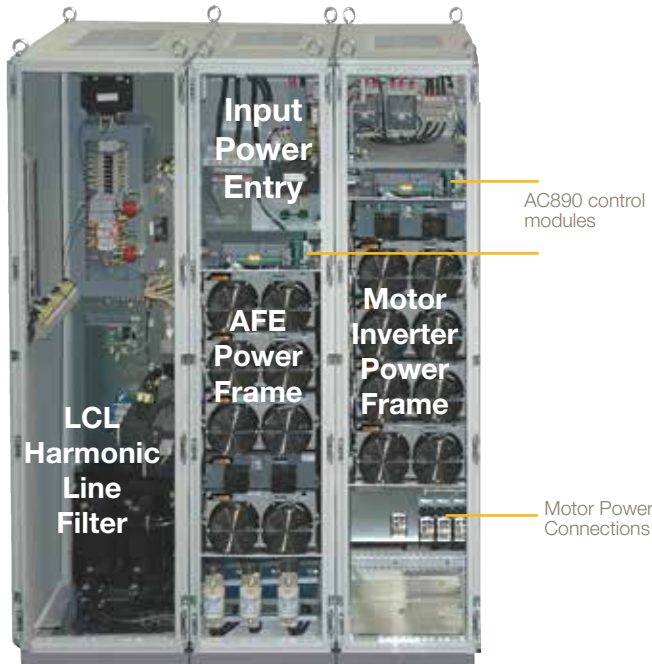

- Fully line regenerative drive
- Continuous duty at full torque - motoring or braking
- Negligible power line harmonics - meets IEEE519
- Unity power factor
- Compact 3 bay (1600 mm) enclosure
- Grid Tie models also available

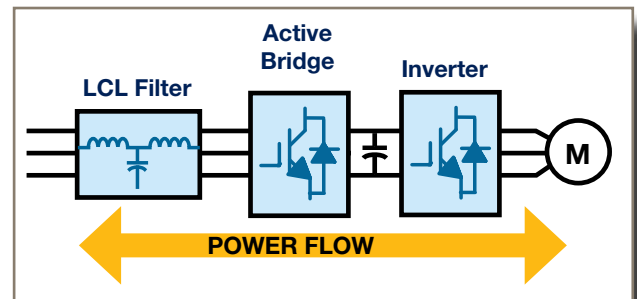

The modular design of the AC890PX makes it easy to configure parallel input modules and multi-phase configurations. By using 12-pulse or 18-pulse configurations, harmful line harmonics can be greatly reduced. Or, for the ultimate in harmonic abatement, an Active Front End (AFE) may be selected. The typical AC drive has six rectifiers in a three phase bridge configuration, and is commonly referred to as a “6-pulse” configuration. A 12-pulse drive contains two sets of six rectifiers, an 18-pulse drive, three sets of six rectifiers and so on. If the AC power connected to each set of rectifiers is “phase shifted”, then some of the harmonics produced by one set of rectifiers will be opposite in polarity from the harmonics produced by the other set of rectifiers. The two (or three) wave forms effectively cancel each other out. To provide the phase shifted AC power, a transformer with multiple secondary windings is used.

Alternative Input Supplies

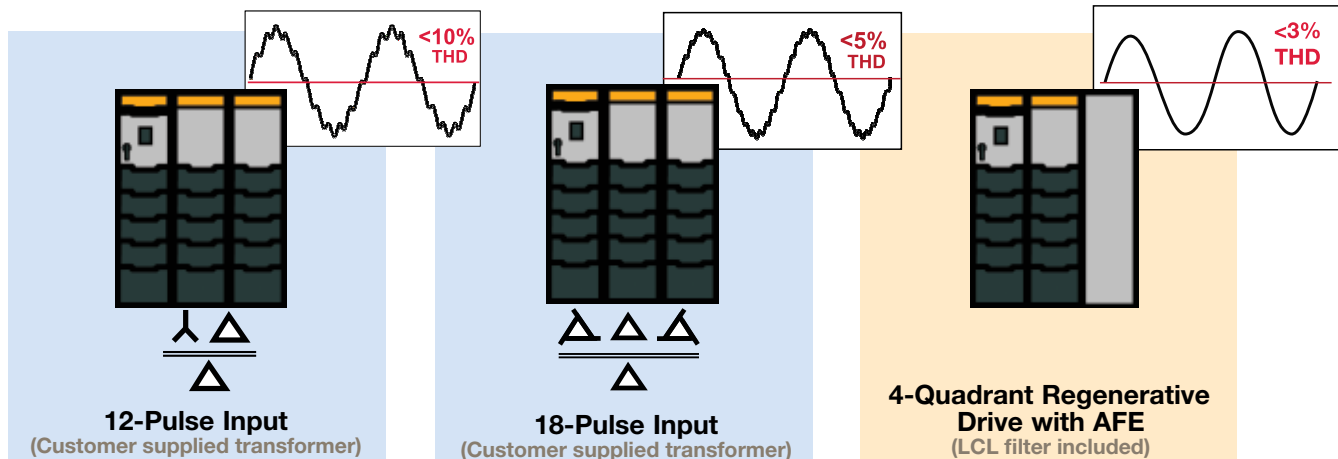

High Power Modular AC Drive

AC890PX Series

150 - 600 HP/110 - 400kW



Technical Specification

Nominal Supply Voltage	VT (Standard duty)	CT (Heavy duty)
400 VAC 3ph +/-10%	132-400kW	110-315kW
460 VAC 3ph +/-10%	200-600HP	150-500HP
575 VAC 3ph +/-10%	200-500HP	150-400HP
690 VAC 3ph +/-10%	132-400kW	110-315kW
Overload Capacity		
Induction motor - standard duty (Variable Tq)	110% for 60 sec	
Induction motor - heavy duty (Constant Tq)	150% for 60 sec	
PMAC motor - heavy duty (Constant Tq)	150% for 60 sec	
Output Frequency	0 - 590 Hz in V/F mode 0 - 350 Hz in Closed loop vector mode 0 - 120 Hz in Sensorless vector mode	
Switching Frequency	2 kHz (standard) - Adjustable 4 kHz (derating required, consult factory). Suppression of audible frequencies	
Dynamic Braking	Dynamic braking module integrated as standard (limited service db resistor included). External braking resistor optional.	
Operating Temperature	0°C to 40°C, derate 1% per degree over 40°C to maximum of 50°C	
Altitude	Up to 1000m ASL (derate 1% per 100m to 4600m max)	
IP Rating	IP 21/UL (c-UL) Enclosed Type 1 as standard. Higher ratings are available - consult factory for quotation	
Dimensions	86.7" (2203mm) H x 19.9" (505mm) W x 25.6" (650mm) D (Height includes 8" (203mm) vent hood)	
Enclosure Rating (Radiated emissions)	EMC Enclosure Standard	Attenuation to RF in spectrum 30-1000MHz
	EN61800-3 Category C3	NONE
	EN61800-3 Category C2 Restricted Distribution EN61000-6-3	10db
	EN61800-3 Category C1 Unrestricted Distribution EN61000-6-4	20db
Safety rating	STO - Category 3 to ISO13849-1 PLe, SIL3	
Humidity	85% maximum humidity at 40°C, non-condensing	
Atmosphere	Non flammable, non corrosive, dust free	
Climate	Class 3k3, as defined by EN50178 (1998)	
Vibrations	Test Fc meeting EN60068-2-6. 10Hz<=f<=57Hz sinusoidal 0.075mm amplitude, 57Hz<=f<=150Hz sinusoidal 1g, 10 sweep cycles per axis on each of three mutually perpendicular axis	
Pollution Index	Degree II (non-conductive pollution, except for temporary condensation)	
Europe	Low Voltage Directive 73/23/EEC with amendment 93/68/EEC, Article 13 and Annex III, EN50178 (1998) Conforms to EN61800-3 (second environment)	
North America / Canada	Product conforms to UL specifications.	

Safe Torque Off - STO

The AC890PX features Safe Torque Off functionality as standard, offering users protection against unexpected motor start-up in accordance with EN18849-1 PL-e or SIL3. Two independent STO control channels are implemented in hardware. A fault in one control channel will not affect the other channel's ability to prevent the drive from starting, i.e. the STO function of the is tolerant to any single fault. It may not be tolerant to an accumulation of faults. This is in keeping with its declared safety ratings. If one or both STO control inputs is requesting the STO function, the drive will not start, even if for example, the drive's software malfunctions and tries to cause the motor to turn. The STO function is implemented in hardware; it overrides all software activities. The only software involvement is to report STO status to the user via an MMI, serial communications link or user terminal on the AC890 control board as defined by the drive configuration.

Note: STO is an electronic inhibit intended for use during normal operation of the machine. It is not intended for use during machine maintenance, repair, replacement or other similar activities. For these activities recognized electrical power isolation devices and lock-out procedures must be used.

High Power Modular AC Drive

AC890PXP Series

Solutions above 600 HP



Description

The flexible nature of the AC890PX means that higher power ratings of up to 1800HP (1200kW) can be provided as well as the standard catalog ratings. These larger AC890PXP units use the same modular construction as the standard AC890PX, with replaceable phase modules, built into multiple bay cabinets.

Power ratings of over 1000HP (750kW) can be supplied with

Parker's 2-phase advanced cooling system, which uses a non-conductive liquid refrigerant. This enables Parker to offer high power inverters with one of the highest power densities available in the market, and its customers to benefit from smaller form factors and increased floor space.

The high power AC890PXP is also available as a DC input inverter, AC input converter, grid-tie

inverter and fully line regenerative four-quadrant drive. With this flexibility and line voltage ratings up to 690 VAC, the AC890PXP covers applications including industrial motor control, solar and wind power, and utility scale energy storage.

Please contact the factory to obtain pricing on an AC890PXP to meet your specifications.



High Power Modular AC Drive

AC890PX High Power Modular AC Drive

150 - 600 HP/110 - 400kW



Electrical Characteristics

Part Numbers	Induction motor ratings					PMAC motor ratings *	
	Constant Torque		Variable Torque		Maximum current w/o overload	Constant Torque	Variable Torque
	Power	Output Current (A)	Power	Output Current (A)		Output Current (A)	Output Current (A)
400 VAC nominal							
890PX/4/0215/B/00/A	110 kW	215 A	132 kW	260 A	265 A	155 A	190 A
890PX/4/0260/B/00/A	132 kW	260 A	160 kW	340 A	347 A	185 A	245 A
890PX/4/0300/B/00/A	160 kW	300 A	200 kW	390 A	398 A	210 A	285 A
890PX/4/0420/B/00/A	200 kW	420 A	250 kW	480 A	487 A	295 A	350 A
890PX/4/0480/B/00/A	250 kW	480 A	315 kW	600 A	609 A	340 A	435 A
890PX/4/0520/B/00/A	280 kW	520 A	355 kW	660 A	670 A	365 A	475 A
890PX/4/0580/B/00/A	315 kW	580 A	400 kW	720 A	731 A	410 A	520 A
460 VAC nominal							
890PX/4/0215/B/00/A	150 HP	200 A	200 HP	250 A	255 A	140 A	180 A
890PX/4/0260/B/00/A	200 HP	250 A	250 HP	320 A	326 A	175 A	230 A
890PX/4/0300/B/00/A	250 HP	300 A	300 HP	380 A	388 A	210 A	275 A
890PX/4/0420/B/00/A	300 HP	380 A	400 HP	480 A	487 A	270 A	350 A
890PX/4/0480/B/00/A	400 HP	460 A	500 HP	590 A	599 A	325 A	425 A
890PX/4/0580/B/00/A	500 HP	580 A	600 HP	700 A	711 A	410 A	505 A
575 VAC nominal							
890PX/6/0130/B/00/A	150 HP	160 A	200 HP	210 A	214 A	90 A	120 A
890PX/6/0160/B/00/A	200 HP	210 A	250 HP	250 A	255 A	115 A	145 A
890PX/6/0190/B/00/A	300 HP	260 A	300 HP	310 A	316 A	140 A	180 A
890PX/6/0280/B/00/A	150 HP	310 A	400 HP	420 A	426 A	170 A	240 A
890PX/6/0340/B/00/A	400 HP	410 A	500 HP	480 A	487 A	220 A	275 A
690 VAC nominal							
890PX/7/0130/B/00/A	110 kW	130 A	132 kW	160 A	163 A	60 A	85 A
890PX/7/0160/B/00/A	132 kW	160 A	160 kW	190 A	194 A	75 A	105 A
890PX/7/0190/B/00/A	160 kW	190 A	200 kW	240 A	245 A	85 A	130 A
890PX/7/0230/B/00/A	200 kW	230 A	250 kW	280 A	286 A	105 A	150 A
890PX/7/0280/B/00/A	250 kW	280 A	315 kW	340 A	347 A	125 A	185 A
890PX/7/0320/B/00/A	280 kW	320 A	355 kW	390 A	398 A	145 A	210 A
890PX/7/0340/B/00/A	315 kW	340 A	400 kW	430 A	436 A	155 A	235 A

PMAC motor ratings use 4 kHz switching frequency

Selection and Part Numbers

AC890PX High Power Modular AC Drive

150 - 600 HP/110 - 400kW



Part Number Key

					Example ▶	890	PX	/	4	/	0580	/	B	/	00	/	A	/	US						
Product Family	AC890PX Standard High Power Drive					890																			
	AC890PX Conformal Coated PCB High Power Drive					891																			
Product Type	Modular Standalone Drive						PX																		
Power / Current Ratings	Supply Voltage	kW	Output Current (A)	HP																					
	380-460V AC nominal								4																
		110	215	150							0215														
		132	260	200							0260														
		160	300	250							0300														
		200	420	300							0420														
		250	480	400							0520														
		280	520	-							0580														
		315	580	500																					
	500-575V AC nominal								6																
	600-690V AC nominal								7																
		110	130	150							0130														
		132	160	200							0160														
		160	190	250							0190														
		200	230	-							0230														
	250	280	300							0280															
	280	320	-							0320															
	315	340	400							0340															
Brake Switch	No brake switch																			N					
	Braking control including internal brake resistor (200kJ/2.4kW) and thermal OL protection provided																				B				
Build Options	Top cable entry																				00				
	Bottom cable entry																					01			
	Top entry no line choke																					02			
	Bottom entry no line choke																						03		
Performance	Advanced performance																					A			
	High performance																						H		
Language	French																						FR		
	German																						GR		
	Italian																						IT		
	Polish																							PL	
	Portuguese																							PO	
	Spanish																							SP	
	Swedish																								SW
	English (50Hz)																								UK
	English (60Hz)																								US

Accessories and Options

AC890/AC890PX Series

Table of Contents



Category	Page
Operator Interface	
While every AC890 and AC890PX series drive is shipped with a keypad/display, there are several options available such as a remote keypad kit and a full featured graphical display. In addition, the TS8000 series HMI is fully compatible with the AC890 and AC890PX series.	67
Accessories - Common Bus	
The AC890 series is a natural for common bus applications. Frames B-D can be mounted side by side, and include convenient accessible clamp terminals for bus connections, as well as bus adapters to connect additional rows of drives. For convenience, we offer quality bus bar stock and related accessories so that everything is guaranteed to fit.	67
Options Cards - Communication	
A wide variety of communications cards allow the AC890 and AC890PX series drives to interface with most current and legacy SCADA networks, using both open architecture and proprietary standards. Other cards allow multiple drives to communicate with each other, peer to peer. Field or factory installed.	68
Options Cards - Feedback	
Since the AC890 family is compatible with such a wide variety of motor types, a number of feedback option cards are offered. Choose from a number of encoder and resolver options to match the feedback device on your motor or process line. Field or factory installed.	70
Option Cards - I/O	
Even though the AC890 family comes standard with extensive I/O, certain applications have special requirements. For these, we offer option cards that will accept "master encoder" inputs, registration mark signals, and high resolution analog references. Field or factory installed.	71
Accessories - Mounting and Wiring	
The unique design of the AC890 frame B-D accommodates ductwork and forced air ventilation, and we offer the hardware required in the form of duct and fan kits. For ease of wiring, several pre-manufactured cables are offered.	74
Accessories - Dynamic Braking	
All AC890 drives include braking logic and transistor, but since not every application requires dynamic braking, the resistor assemblies are optional. Braking kits include overload	75
Accessories - Software Tools	
For drive configuration and programming	106
Accessories - Power Quality	
Pre-selected line/load reactors and EMC filters can be provided for the AC890 family.	112



Accessories

AC890/AC890PX Series



Operator Interface

Model	Description
6511/TTL/00	4 Digit LCD keypad*
6901/00/G	Alphanumeric multilingual keypad**
6052/00	Remote mounting kit for 6901 with 3m cable
TS8000 series	Full featured HMI - purchased separately

*Standard equipment for frames B - D

** Standard equipment for frames E - K and All AC890PX



6511/TTL/00



6901/00/G



Keypad Blanking Cover

The keypad blanking cover kit may be used when local keypad is not installed. Kit includes light pipes for LED's.

Part Number	Description	Suitable for
BD467732U002	Blank Cover	AC890 Frame B-D
LA500326U001		AC890 Frame E-J

Cables

Model	Description
CM471050	USB programming cable for AC890/AC890PX
8905/FWCBL200/00	FireWire cable 200 mm (B frame to B, C, D frame)
8905/FWCBL280/00	FireWire cable 280 mm (C, D frame to B, C, D frame)
8905/FWCBL1000/00	FireWire cable 1000 mm (Rack to rack)
8905/FWCBL4500/00	FireWire cable 4.5 m (Rack to rack to enclosure)
CM471585U001	Drive to LA471585 module cable, 1 meter
CM471585U002	Drive to LA471585 module cable, 2 meter
CM471585U003	Drive to LA471585 module cable, 3 meter
CM471592	Extended LA471585 to LA471585 cable, 2 m

Common Bus System

Model	Description
BH465850	1 meter DC Rail/Bus Bar, copper 140A
BC465938U200	Insulator for DC bus bars 200mm
BA469216	1 meter Grounding bus bar
890CA/5/0050B/N/00/N/EN	Common bus adapter, 50A, w/bus capacitors
890CA/5/0080B/N/00/N/EN	Common bus adapter, 80A, w/o bus capacitors

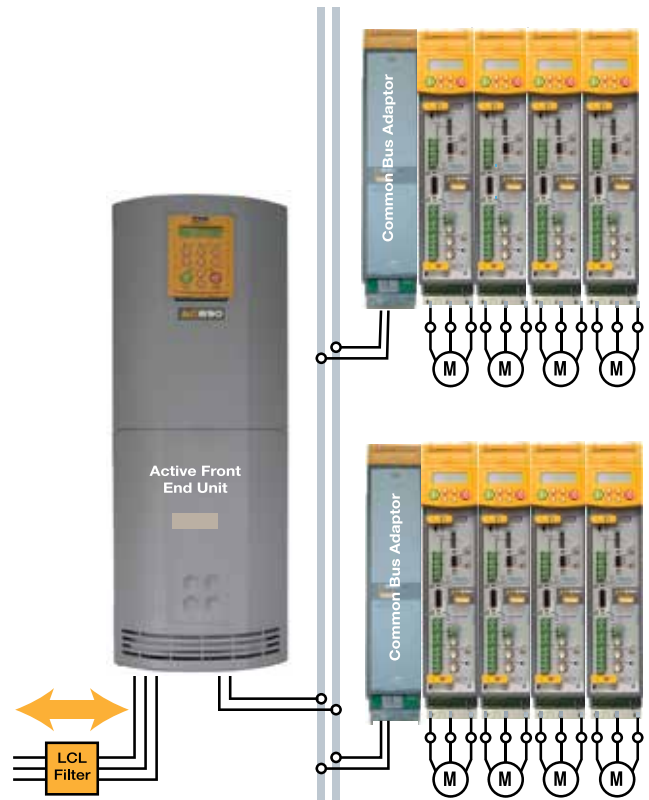

Example of a common bus system using multiple AC890 CD units with a single AC890 AFE. Bus bar connects 4 drives together with Common Bus Adaptor, which connects additional rows of drives to main DC bus. The common bus adapter includes the necessary fuses.

Options

AC890/890PX Series

Communication Interfaces



Ethernet/IP (8903/IP/00)	
Supported Protocols	Ethernet IP, Level 2 I/O Server CIP
Communication speed	10/100Mbps/s
Station Address	By DSE software via RTNX protocol
Connection support	4 class 1 (cyclic I/O data transfer), 16 class 3 (explicit messaging)
Interface	RJ45
Suitable for Drives	AC890/AC890PX version 3.2+
Modbus/TCP (8903/IM/00)	
Communication speed	10/100Mbps/s
Station Address	By DSE software via RTNX protocol
Connection support	Up to 4 simultaneous connections
Interface	RJ45
Suitable for Drives	AC890/AC890PX version 3.2+
EtherCAT (8903/CT/00)	
Supported Protocols	CANopen over EtherCAT (CoE)
Communication speed	100M bits/s
Features	DS301 compliant, EMCY support
Interface	RJ45 in/RJ45 out
Suitable for Drives	AC890/AC890PX version 3.7+
DeviceNet (8903/DN/00)	
Supported Protocols	Supports the group 2 only slave subset of the DeviceNet protocol
Supported Messages	Polled I/O, Cyclic Outputs, Change of State (COS), Explicit Messaging
Communication Speed	125K, 250K et 500K bits/s
Station Address (MACID)	DIP switch or software setting of station address and network speed
Interface	5-position removeable terminal strip
Suitable for Drives	AC890/AC890PX version 1.9+
ControlNet (8903/CN/00)	
Supported Messages	Polled I/O
Station Address	Selectable by DSE software or hardware switches
Data capacity	Up to 504 bytes of producer data and 504 bytes of consumer data
Interface	2 Co-axial RG-6 connectors (channel A, B), RJ45 network access port
Suitable for Drives	AC890/AC890PX version 1.4+
Profinet/IO (8903/PN/00)	
Supported Protocols	Profinet I/O Real-time (RT) Protocol
Communication speed	100Mbps/s
Station Address (IP)	Software setting of IP address via DSE
Interface	RJ45
Suitable for Drives	AC890/AC890PX version 3.3+

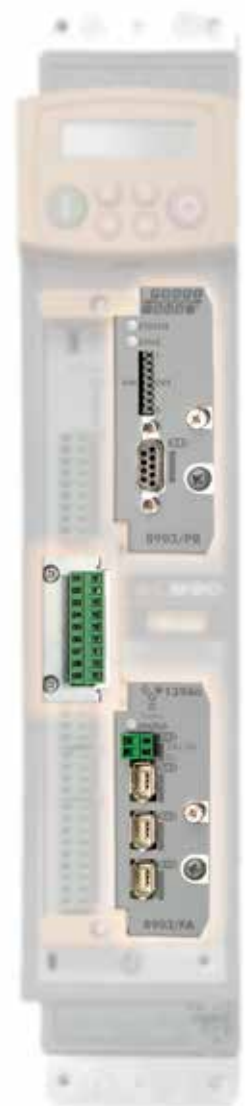

**Plug-in Design
for easy field
installation of all
communications
options, or order
factory installation...
your choice!**

Options

AC890/890PX Series

Communication Interfaces



Peer to Peer (8903/SP/00)

Supported Protocols	Peer to peer data exchange with other AC890/AC890PX drives
Communications Speed	Up to 1Mbits/s selectable by DIP switch
Station Address	DIP switch
Interface	5-position removable terminal strip
Suitable for Drives	AC890/AC890PX version 3.3+

FireWire IEEE 1394 (8902/FA/00)

Communication Supported	Peer-to-Peer communication between drives via IEEE1394 standard
Communication Speed	Up to 400 MBaud
LA471480	Firewire Repeater Kit - includes 100 ft. CAT5 cable
Interface	3 IEEE1394a Firewire ports, removable terminal strip for 24V power input
Suitable for Drives	All AC890/AC890PX

RS485/Modbus (8903/RS/00)

Supported Protocols	Slave Modbus RTU
Communication Speed	1200 to 115200 bits/second
Interface	RS485 2 wire
Station Address	Selectable via software
Suitable for Drives	AC890/AC890PX version 3.7+

CANopen (8903/CB/00)

Profile	DS402
Supported Messages	SDO, PDO, NMT, SYNC
Communication Speed	20K, 50K, 125K, 250K, 500K, 1Mbits/s selectable by software or DIP switch setting
Station Address	DIP switch or software setting of station address
Interface	5-position removable terminal strip
Suitable for Drives	AC890/AC890PX version 1.3+

Profibus-DP (8903/PB/00)

Supported Protocols	Profibus-DP ; Demand Data and Data Exchange
Communication Speed	Up to 12M bits/s selected by the master
Station Address	DIP switch or software setting of station address
Interface	9-pin D-sub connector
Suitable for Drives	AC890/AC890PX version 1.4+

Note: Part numbers above refer to option cards provided loose. To order an option card factory installed in a drive, change the last two digits from "00" to "FF".

Options

AC890/890PX Series

Feedback cards

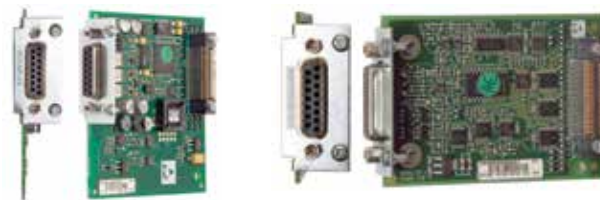

8902/RE/00 - Resolver

The 8902/RE resolver speed feedback option allows the resolver to be connected directly to the drive to provide highly accurate speed feedback measurement. Contains a carrier output signal to power the resolver.

Part Number	Description
8902/RE/00/00	Optional Resolver feedback card
8902/RE/00/FF	Optional Resolver feedback factory-installed

Features

Maximum Speed	Up to 50,000 RPM (with 2 pole resolver)
Carrier Output Signal	7V rms, 8kHz
Maximum Carrier Supply	70mA rms
Maximum Input Voltage	±12V peak
Accuracy	< 5 minutes
Resolution	Equivalent to 16 bits in one revolution of resolver
Inputs	Differential inputs Zin ~2 kΩ
Maximum Input Voltage	12V peak

8902/M1/00 - Sin/Cos Encoder

The Sin/Cos Registration Option allow 1Volt peak-to-peak Sin/Cos encoders to be connected directly to the motor controller to provide highly accurate speed feedback measurement and registration. It may be used in conjunction with 8903/M1 for systems requiring two simultaneous encoder inputs. See page 72 for more information.

Part Number	Description
8902/M1/00/00	Optional encoder feedback card
8902/M1/00/FF	Optional encoder f/b card factory-installed

Features

Maximum Pulse Rate	250kHz
Receiver Impedance	120Ω
Input Format	2 differential 1V p-p signals in quadrature
Encoder Supply	250mA maximum load
Supply Voltage	5V/10V adjustable
Terminal Type	15 pin D-Sub connector
Maximum Cable Length	150m shielded cable
Serial Protocol	Endat 2.1

8902/EQ/00 - HTTL Encoder

The HTTL 8902/EQ speed feedback option allows incremental encoders to be connected directly to the drive to provide highly accurate speed feedback measurement. Supplies variable voltage isolated encoder power supply.

Part Number	Description
8902/EQ/00/00	Optional HTTL incremental encoder
8902/EQ/00/FF	Option HTTL encoder factory-installed

Features

Maximum pulse rate	250kHz (differential) 200kHz (single ended)
Receiver current	≤10mA per channel
Input Format	Two differential channels in quadrature (Clock/direction or clock only)
Input Voltage	±30V (differential), 0-30V (single-ended)
Input Voltage Differential	±30V maximum
Input Voltage Threshold	3V ± 1V (differential) 8V ± 1V (single-ended)
Encoder Power Supply	Maximum load 200mA or 2W Voltage adjustable 10V to 20V by firmware

Options

AC890/890PX Series

I/O Cards



8903/EP/00 - Encoder Input

The 8903/EP encoder input option allows an incremental encoder input as a reference, and provides a synthesized encoder output. The input features optically isolated differential inputs for channels A, B and Z. All inputs are compatible with RS422 and RS485 encoders, as well as encoders that provide output voltages as high as +/-30V. All decoding logic required to interface the encoder input to the drive is provided. Three non-isolated differential digital outputs are used for synthesizing an encoder output. Installed along with an 8902-EQ incremental encoder option, the board can be used to create an electronic line shaft between the reference and feedback encoders.

Part Number	Description
8903/EP/00/00	Optional Encoder Input card
8903/EP/00/FF	Optional Encoder Input factory-installed

8903/AI/00 - Hi-Res Analog Input

The 8903/AI card adds a high resolution analog input to the drive. In addition to all of the features and functionality of the 8903/EP encoder option board above, the 8903/AI includes a 15 bit plus sign +/-10V analog input. This makes the drive suitable for applications, where the drive follows a precision analog speed set point from a CNC and send back to the CNC the position of the controlled axis. It provides the fast response times required for accurate position control.

Part Number	Description
8903/AI/00/00	Optional High Resolution Analog Input and Encoder Input card
8903/AI/00/FF	Optional High Resolution Analog Input and Encoder Input factory-installed

Features

Encoder Input	8903/EP and 8903/AI
Maximum Pulse Rate	250kHz
Receiver Current	≤10mA per channel
Input Format	Two differential channels in quadrature, clock/dir or clock only
Input Voltage Range	±30V (differential) 0-30V (single-ended) or RS422/485
Input Voltage Threshold	< 2V (differential) 8V ± 1V (single-ended)
Synthesized Encoder Output	8903/EP and 8903/AI
Supply Voltage	30V
Operating Input Supply Voltage (VS)	5V to 24V Absolute Maximum
Maximum Output Frequency	250kHz on each output
Maximum Output Current	± 100mA per output
Output Voltage	Low logic level < 3V @ 100mA High logic level > VS – 4V @ 100mA
Overload and short circuit duration	Indefinite
Maximum cable length *	150 meters
Analog Input	8903/AI Only
Resolution	15 bits + sign
Input voltage range	+/- 10V
Input Format	Differential
Input Impedance	100k-ohm
Input low pass filter	3kHz

Plug-in Design for easy field installation of all feedback and I/O options, or order factory installation... your choice!



Options

AC890/890PX Series

Sin/Cos registration position



8903/M1/00, 8902/M1/00

Description

The 8903/M1/00 and 8902/M1/00 feedback cards allow operation without external registration position, thanks to the connection of the encoder to the drive. They provide highly accurate speed feedback measurement and registration. Nevertheless registration applications are best achieved when both cards are used.

- Registration achieved **in the drive** (“High Performance” AC890 model only)
- Interpolates each encoder line with 11-bit accuracy giving 4 million counts/rev. on a 2048 line encoder
- Optional 1V input from ‘Z’ index pulse for use with registration
- Supplies 5V or 10V to the encoder
- Decodes Heidenhain Endat 2.1 absolute position encoders
- 4 optically isolated auxiliary digital outputs that can be used either for general purpose inputs, or for inputs from registration mark sensor (8903/M1 only)
- 3 non-isolated auxiliary digital outputs that can be either for general purpose outputs or for synthesizing an encoder output (8903/M1 only)

Part Number	Description
8902/M1/00	Slave SinCos registration
8903/M1/00	Master SinCos registration
8902/M1/FF	Slave SinCos registration factory-installed
8903/M1/FF	Master SinCos registration factory-installed

Approved Encoders	1V p-p	Endat 2.1	Single Turn ABS	Multi-turn ABS
Heidenhain :				
EQN425	√	√		√
ECN413	√	√	√	
ERN480	√			
Stegmann :				
HG660 AKR (xxxx)S	√			
HG660 DKR (xxxx)S	√			
Hengstler :				
RIS58-H	√			

Specification

Encoder Inputs (8902/M1 and 8903/M1)

Maximum Pulse Rate	250kHz
Receiver Impedance	120Ω
Input Format	2 differential 1V p-p signals in quadrature
Encoder Supply	250mA maximum load
Supply Voltage	5V/10V adjustable
Terminal Type	15 pin D-Sub connector
Maximum Cable Length	150m screened cable
Serial Protocol	Endat 2.1

Auxiliary digital input (8903/M1 only)

Low Logic Level	0V to 5V relative to X63 pin 5
High Logic Level	15V to 26V relative to X63 pin 5
Absolute Max. Input Voltage	30V relative to X63 pin 5
Input Current	Low logic level < 1mA High logic level > 3mA, < 10mA Typical input at 24V : 7mA
Isolation withstand relative to drive chassis	30V
Input Safety Category	SELV
Terminal Type	6-way pluggable 3.5mm terminal block
Maximum Cable Length	150m screened cable is recommended for all lengths, but essential if over 30m in order to comply with EMC regulations

Auxiliary digital outputs (8903/M1 only)

Input Voltage (VS)	5V to 24V
Maximum Input Voltage	30V
Maximum Output Current	± 100mA per output
Output Voltage	Low logic level < 3V to 100mA High logic level > VS – 4V to 100mA
Overload and short circuit duration	Indefinite withstand
Max. Output Frequency	250kHz per output
Terminal Type	8-way pluggable 3.5mm terminal block
Maximum Cable Length	150m screened cable is recommended for all lengths, but essential if over 30m in order to comply with EMC regulations

Options

AC890/890PX Series

SinCos registration position



Possible Configurations

	8902/M1 installed in slot F 8903/M1 not installed	8902/M1 not installed 8903/M1 installed in slot A	8902/M1 installed in slot F 8903/M1 installed in slot A
Speed feedback Encoder	Via 8902/M1 card	Via 8903/M1 card	Via 8902/M1 card
Reference Encoder Signal		In this combination, a reference encoder position would normally be supplied by a FireWire option interface (8903/FA)	Supplied by 8903/M1 card
Registration	Available only using the encoder's 1V index pulse.	Auxiliary digital inputs and the encoder's index pulse (if supplied by the encoder) for registration event inputs	Auxiliary digital inputs and the encoder's index pulse (if supplied by the encoders) from both encoders are available for registration event inputs
Inputs/Outputs		The auxiliary digital inputs are also available for general purpose digital inputs. Auxiliary digital inputs are also for simulated pulse encoder output, or for general purpose digital output	The auxiliary digital inputs are also available for general purpose digital inputs. Auxiliary digital inputs are also for simulated pulse encoder output, or for general purpose digital output

Example of two-mark registration

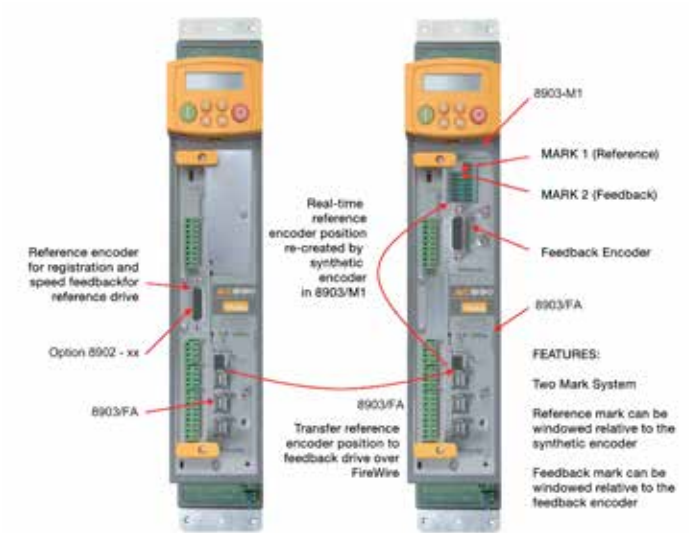
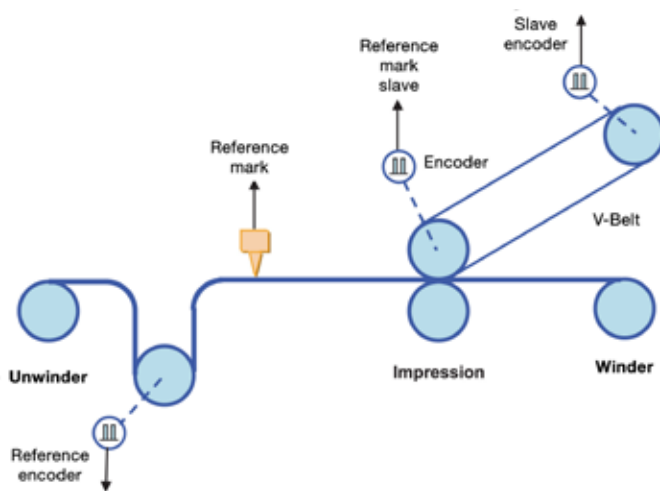

Accessories

AC890/AC890PX Series

Mounting and Wiring



Building your own system enclosure? Let Parker provide the necessary pre-engineered hardware to save you time and expense. Our installation kits and components come with guaranteed compatibility with the AC890 drives. All from a single source: Parker Electromechanical and Drives Division.

Ventilation Components

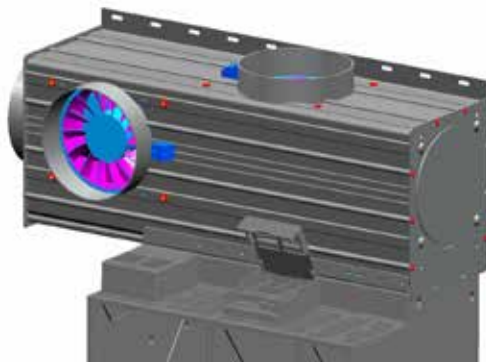

AC890 air ducting components make easy work of cabinet building when force ventilation is to be used. The exhaust duct, supplied in 1 meter sections, is mounted to the top of the AC890 heatsinks and includes a 190 CFM fan. This arrangement provides a very effective means of cooling by drawing air directly through the drives' heat sinks and out of the air outlets which can be flex-ducted out of the cabinet. See part numbers in table to right.

LA471585 I/O Terminal Interface



The I/O Terminal Interface Module saves time and provides for a clean panel layout when used with the AC890 series drive. The module is mounted on DIN rail and connected to the X12, X13, X14, and X15 I/O connectors on the AC890. With this module, 15 I/O points are accessible through push-type terminals, eliminating the need for a screwdriver and any concerns about loose wiring. For multi-drive systems, the interface modules can be mounted side by side, and with the included keyed jumper, will share Coast Stop and Program Stop commands from the lead drive, as well as the 24VDC auxiliary supply. If modules are not to be mounted directly adjacent, there is an optional 2 meter bus jumper cable available.

Parker also offers pre-made cables in three lengths for easy connection to the AC890 drive. See part numbers in table below.

Part Number	Description
LA468430U003	Installation kit for 890CS/CA
LA468430U103	Installation kit for 890CD, Frames B-D
LA468430U203	Installation kit for 890SD, Frames B-D
8905/DUCTKIT/00	Ventilation duct kit, 1 meter exhaust duct, one 190 CFM fan kit. Frame B-D
8905/DUCTFAN/00	Ventilation duct fan, 190 CFM, with flange (additional or replacement fan for duct kit)
LA466717U004	Exhaust duct kit, Frame E
LA466717U003	Exhaust duct kit, Frame F
CI465892U008	Shield Grounding Clamp 8 mm (One included with drive)
CI465892U014	Shield Grounding Clamp 14 mm
CI465892U020	Shield Grounding Clamp 20 mm
CI468595U015	Dsub-15 pin to discrete terminal strip (in shell)
VM15	Breakout Module - Dsub 15 to DIN rail terminal strip
LA471585	I/O terminal interface module, DIN rail mount

Options

AC890/890PX Series

Dynamic Braking Kit

D/B Kit includes resistor, overload, protective cage, and enclosure top or panel mounting							
Part Number	Voltage	HP - CT	HP - VT	Ohms	Amps	Watts	Dimensions (in) LxWxH
AC890SD Models							
LA471355	230	1		200	0.71	100	6.5x1x1.6
LA471356		2		100	1	100	6.5x1x1.6
LA471358		3		56	1.89	200	6.5x1.2x2.4
LA471385		5, 7.5	10	25	3.9	380	13.5x4x5
LA471386		10	15	15	5	375	13.5x4x5
LA471353	460	1		500	0.35	60	4x1x1.6
LA471355		2		200	0.71	100	6.5x1x1.6
LA471355		3		200	0.71	100	6.5x1x1.6
LA471356		5		100	1	100	6.5x1x1.6
LA471357		7.5		100	1.42	200	6.5x1.2x2.4
LA471358		10		56	1.89	200	6.5x1.2x2.4
LA471359		15		56	2.99	500	13.2x1.2x2.4
LA471361		20		30	5	750	13.5x7x5
LA471362		30		25	5.5	756	13.5x7x5
LA471350		40		22.5	7.1	1134	13.5x10x5
LA471364		50	60	18	7.9	1123	13.5x10x5
LA471365		60	75	15	8.7	1135	13.5x10x5
LA471367		75	100	8	13.7	1502	13.5x13x5
LA471367		100	125	8	13.7	1502	13.5x13x5
LA471369		125	150	6	19.4	2258	13.5x10x5
LA471369		150		6	19.4	2258	13.5x10x5
LA471370		200	250	3	39	4563	20x18x10
LA471372	250	300	2.25	45	4556	20x18x10	
LA471372	300	350	2.25	45	4556	20x18x10	
LA471375	350	400	1.5	55	4538	20x18x10	
LA471375	400	450	1.5	55	4538	20x18x10	
LA471375	450	500	1.5	55	4538	20x18x10	
LA471376	500	550	1.2	61	4465	20x18x10	
AC890CS Module							
LA471377	230	10		20	4.3	370	13.5x4x5
LA471378		20		10	8.7	757	13.5x7x5
LA471379		40		6	13.7	1126	13.5x10x5
LA471380		60		4	19.4	1505	13.5x13x5
LA471349	460	25		40	4.3	740	13.5x7x5
LA471350		45		22.5	7.1	1134	13.5x10x5
LA471351		90		12	11	1505	13.5x13x5
LA471352		135		9	15.8	2247	13.5x10x7.5

*NEMA ICS 3-301.62 Dynamic braking stop option. Minimum 100% full load torque from base speed with 6x motor inertia, and 4 stops per hour.

Software Tools

For All Drives with communications

Drive System Explorer Software

DSE is the programming, monitoring and diagnostic software platform for most Parker drives. Thanks to the on-line help, users can achieve the optimum drive configuration without the need to navigate through complicated parameter menus. Advanced programming is carried out through a set of pre-engineered templates in order to create the required configuration. It is possible to monitor every parameter of the drive either as a digital value or as a function in the “chart recorder” during normal operation.

While the drive is in running mode the oscilloscope function allows “on-line” monitoring of selected parameters and the recording of trends. Using straightforward block programming, DSE allows the user to create, parameterize and configure user defined applications thanks to function blocks dedicated to speed control, inputs, outputs, ramps, winder functions, PID, diameter calculator, and more. Groups of function blocks can be combined into macros for more complex programs.

There are three levels of DSE software available.

- DSE Lite is provided as a free download, and is a fully functional package for drive programming, configuration, status monitoring, and diagnosis.
- DSE Development software adds the capability to create and edit projects using AC890 with Firewire communications.
- DSE Runtime allows the user to edit projects using AC890 with Firewire communications, but not create new ones.

For users of DSD software who wish to migrate to the DSE platform, we offer upgrade packages for both development and runtime versions of that product.

System Requirements

- Windows Vista® or Windows® XP, Home or Professional Edition operating system
- 100Mb of free hard disk space
- USB port for connecting to an AC890 or AC890PX drive
- Serial port for connecting to AC650V, AC690+, DC590+, or legacy drives.

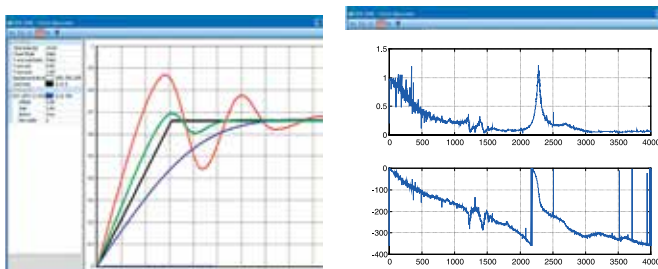

Real-time data acquisition and oscilloscope functions

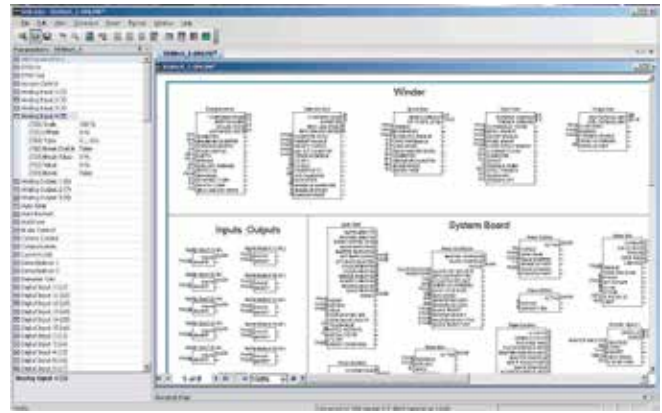

Function block configuration

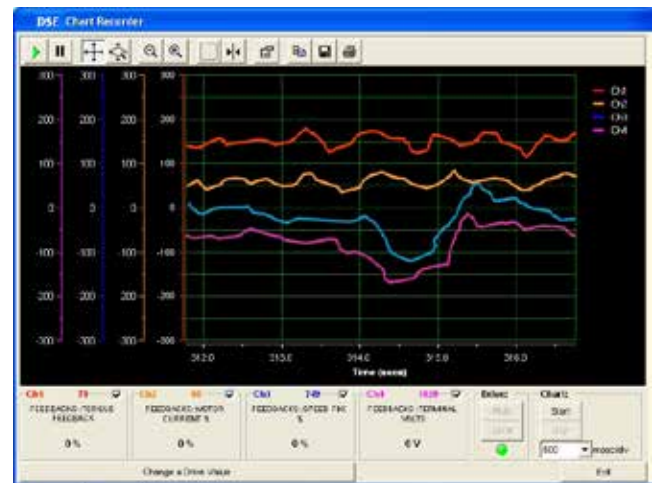

Chart recorder function

Part Number	Description
DSE-Lite	DSE Lite software (single axis) + USB cable*
8906-DSEDEV-00	DSE Development software + USB cable
8906-DSEDEV-00	DSE Runtime/Maintenance + USB cable
8906-DSEDEVUPG-00	DSD Development to DSE Development Upgrade + USB cable
8906-DSEDEVUPG-00	DSD Runtime to DSE Runtime Upgrade + USB cable

* DSE Lite may also be downloaded free of charge



EMC Filters

for AC and DC Drives

Description

A range of pre-selected EMC (Electromagnetic Compatibility)/RFI (Radio Frequency Interference) Filters are available, suitable for all drives. These filters are a cost effective and easily implemented solution for the abatement of EMC in order to meet certain directives. Installation of the drive must be in accordance with the installation guidelines in the product manual.

Filters described as “footprint” type are designed to save panel space by mounting behind the drive. Filters described as “bookshelf” are designed for mounting compatibility and integration with the AC890 series frames B - D.



Drive mounted on a “footprint” filter

Ordering

Part Number	Rating	Type	Description
CO467842U105	105A	Footprint	Filter for Frame E AC890SD Drive
CO467842U215	215A	Footprint	Filter for Frame F AC890SD Drive
CO467843U340	340A	External	Filter for Frame G, H or J AC890SD Drive
CO469330	54A	Bookshelf	Filter for Frame B AC890CS (Dimensions: See AC890 Frame C pg 56)
CO469331	162A	Bookshelf	Filter for Frame D AC890CS (Dimensions: See AC890 Frame D pg 56)

Three phase reactors

for AC Drives

Description

Parker's range of reactors have been especially selected to match the requirements of the Parker AC drive range and can be used on either the input or output sides of the drive. They are used to add inductance to reduce the harmonic content of the supply current. A reactor installed in the drive output limits the capacitive current when motor cable runs in excess of 50m are used. It prevents overcurrent trips and temperature rise of the motor.

In addition to helping with compliance with IEEE 519 there are other benefits to using line/load reactors including:

- Increased drive system reliability
- Reduced harmonics / surge currents
- Reduced motor noise and temperature
- Improved true power factor

Ordering

Part Number	Line Voltage	Current	Drive HP (CT)	Impedance
CO470653	230	4A	1	3mH
CO353011		8A	1.5 / 2	1.5mH
CO470638		12A	3	1.25mH
CO353012		18A	5	0.8mH
CO353013		25A	7.5	0.5mH
CO353014		35A	10	0.4mH
CO353015		45A	15	0.3mH
CO353016		55A	20	0.25mH
CO353017		80A	25 / 30	0.20mH
CO470654		100A	40	0.15mH
CO353018		130A	50	0.1mH
CO470058		160A	60	0.075mH
CO470650		460	2A	1
CO470651	4A		2	6.5mH
CO352782	8A		3	5mH
CO470652	8A		5	3mH
CO352783	12A		7.5	2.5mH
CO352785	18A		10	1.5mH
CO352786	25A		15	1.2mH
CO352901	35A		20 / 25	0.8mH
CO352902	45A		30	0.7mH
CO352903	55A		40	0.5mH
CO352904	80A		50 / 60	0.4mH
CO352905	100A		75	0.3mH
CO352906	130A		100	0.3mH
CO470057	160A		125	0.15mH
CO470045	200A		150	0.11mH
CO470046	250A		200	0.09mH
CO470047	320A		250	0.075mH
CO470048	400A	300	0.06mH	
CO470049	500A	350 / 400	0.05mH	
CO470050	600A	500	0.04mH	



AC Motors

Inverter and Vector Duty - Compatible with AC890, AC890PX

1 - 500 HP

Description

Parker can provide Inverter Duty and Vector Duty motors that let you get the most out of your drive. With your choice of a wide variety of frame styles, every rating includes specific features demanded by high performance drive applications.

Cast iron frames with totally enclosed non-ventilated construction are available for harsh environments, while compact laminated frame designs with forced ventilation can fit into the tightest spaces while providing 1000:1 constant torque speed range and excellent dynamic performance.

Not all motors are created equal. Don't settle for a re-rated constant speed motor for variable speed applications. All Parker Inverter and Vector Duty motors are provided with insulation that is suitable for use with IGBT based PWM drives, and with 200% torque overload capability. Ask for a performance matched package every time.

RPM AC™ Product Features



The RPM AC™ series of AC motors was designed specifically for optimum inverter duty performance, and offers high performance over a wide speed range. The compact, square cross-section, laminated steel frame includes cast iron brackets with feet for maximum ruggedness and stability. The unique low inertia design allows fast acceleration and high dynamic response. And to assure long and reliable motor life, Corona-Free insulation is used on all RPM ACTM ratings.

- Unique square laminated steel frames (FL210 - L440)
- Most compact, lightest weight
- Cast iron feet and end brackets
- Wide constant HP range - 4:1 to 12:1 available
- Low inertia design for faster dynamic response
- Replace DC motors with minimal mechanical issues
- Corona free insulation system
- Force ventilated open and enclosed blower cooled frames

Available enclosures:

DPG-FV (Drip-Proof Guarded Force Ventilated) - IEC IP23/IC06. Motor cooling is provided by motor-mounted blower driven by an integrally mounted three-phase blower motor.

TEBC (Totally Enclosed Air-Over Blower-Cooled) - IEC IP44/IC416. In-line blower cooled motors incorporate unique integral air ducts in the frame, external to the windings. The integrally mounted, independently powered three phase blowers result in low noise levels over wide speed ranges.

TEFC (Totally Enclosed Fan-Cooled) - IEC IP44/IC411. Exterior surface cooled by external fan mounted on motor shaft.

Encoders: Motors above are available with an encoder suitable for use with Parker AC drives. On some ratings, the encoder is an option, while on others it is provided as standard equipment. The standard encoder is a 1024 PPR quadrature style with mating connector. Please inquire if you have any special encoder requirements.

V*S Master™ Product Features



For applications in tougher environments, we offer V*S Master™, featuring cast iron frame and end shields. Overload is no problem, with 200% capability for 60 seconds. Corona-Free insulation and an insulated CE bearing extend lifetime.

- Cast iron frames and end brackets
- Corona free insulation system
- 200% overload torque for 1 minute
- Three thermostats
- Constant HP to 1.5 times base speed
- Class F insulation
- Stainless steel nameplate
- Re-greaseable bearings
- TEFC ratings provide continuous full load torque from 0 to base speed
- CSA certified and UL recognized

Parker Permanent Magnet Servo Motors

NX Series

2 - 64 Nm (17.7 - 566 in-lb)



Description

Parker NX brushless motors with resolver are the ideal complement to AC890 drives in applications where servo performance is needed. Their main features are as follows :

- 230 and 460 VAC Models
- Compact Size with Low Rotor Inertia
- High Torque at Zero Speed
- High Torque to Inertia Ratio
- 4, 8 and 10 Pole Zero-Cog Designs
- Resolver Feedback Standard
- Rotatable socket plugs standard
- IP64 enclosure standard

For more information, specifications, and dimensions, please visit our website.

PMAC Torque motors

TMW Series

1200 - 22,100 Nm



Description

Parker TMW Torque Motors are innovative direct drive solutions based on permanent magnet brushless technology. Designed with a high pole count for high torque, low speed operation, they advantageously replace traditional gearbox based systems in many applications. In addition to motoring applications, the TMW series is also an effective generator solution for applications in renewable energy, like wind and wave power. The Direct Drive advantages result in more compact, more efficient, quieter and virtually maintenance free drive systems.

The TMW series is well suited to extruder and injection molding applications. Developed in collaboration with machine builders and end-users, a number of innovative, dedicated features have been integrated into the motors, such as a generously sized, integrated thrust bearing to support back pressure from the screw, as well as specific mechanisms allowing quick and easy removal of the screw from the motor. Delivering torques up to 22,100 Nm, at speeds ranging from 50 to 500 rpm, Parker torque motors represent the perfect alternative to gearbox based systems for extruders applications of power up to 320 kW (400 HP).

For more information, specifications, and dimensions, please visit our website.

Application Profile

Process Optimization - Multi-Section Winder

Parker Drives improve process quality while saving energy in a multi-section winder



Summary

Parker C890 Series Modular Systems Drives were the first choice of an industry-leading steel manufacturer when process quality improvements and energy savings were required in a complex, multi-section winding machine .

The AC890 Series solution utilized application -specific function blocks, which provide real-time data logging and trending and provide the user with the ability to optimize the process.

By utilizing a Common DC Bus power supply configuration, the system was able to efficiently manage energy across all motor-drive sets, as well as reduce overall cabinet space.

Benefits

- **Energy saving operation using Common DC Bus configuration**
- **Real-time trending and historical data logging for process application enhancement**
- **Reduced overall cabinet space**
- **High-speed drive communications offering optimum machine speeds**

Parker Drives Solution

AC890 Series Modular Systems Drive

- Integrated winding application function blocks
- Compact footprint with Common DC Bus
- Industry compatible communications

Asynchronous Motors

- Compact with high dynamic performance
- Available with or without cooling fan

Technical Support

- Site survey and project management
- Commissioning and start-up assistance

Application Profile

Process Optimization - Shaftless Printing

Shaftless printing machine control delivers improved performance and quality thanks to AC890

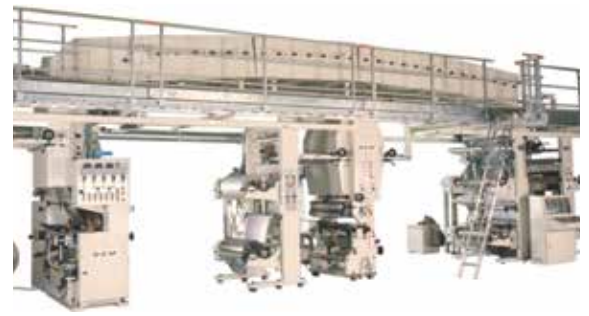

Summary

Parker AC890 Modular Systems Drives were selected when a large end-user print company wanted to upgrade their existing printing line. The integrated shaftless printing function blocks made it a simple task to replace the mechanically linked line shafts with individual AC890 drives capable of precise synchronization and print registration adjustment to each section

The inclusion of high performance brushless motors increased acceleration and deceleration rates allowing greater production throughput and the electronic control of the process simplified and reduced changeover times considerably.

TS8000 HMI's completed the transformation with an integrated web-server and Ethernet connectivity, delivering real-time control and data capture and providing seamless integration to other manufacturing systems.

Benefits

- **Removal of mechanical line shafts reducing maintenance and complexity**
- **Improve acceleration and deceleration speeds**
- **Improved changeover speeds**
- **Reduced waste on changeover**
- **Integrated diagnostics and data handling**
- **Web server delivering real-time production and maintenance information**
- **Registration mark detection and synchronization INSIDE the drive**

Parker Drives Solution

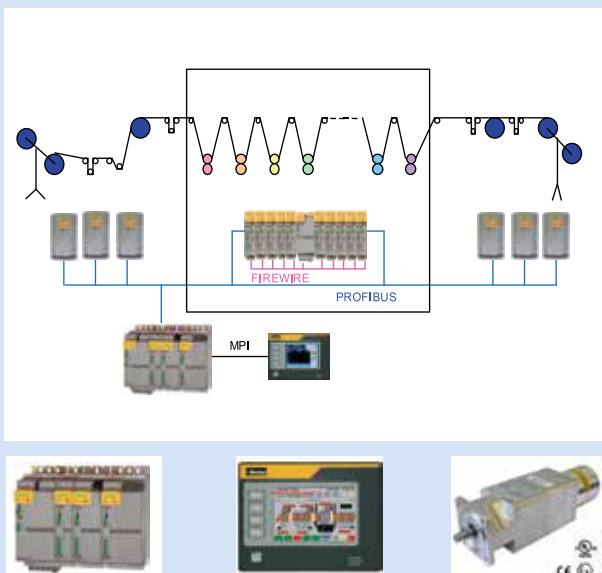

AC890 Modular Systems Drive

- Compact footprint thanks to Common DC Bus configuration
- Common DC Bus allows regenerated power to be shared between machine sections
- AC890 capable of driving a wide range of AC motors with a variety of feedback devices

Total Solutions

- ATEX motors for explosive atmospheres
- Web enabled TS8000 HMI's between 3" and 15" to suit all visualization requirements

Application Profile

Energy Savings - Pump applications

Pumping station retrofit reduces energy costs by replacing eddy current clutch



Summary

The wastewater treatment plant in Rock Hill, South Carolina turned to Parker when it needed to reduce energy and replace an obsolete eddy current clutch system on three 200 HP waste water lift pumps. By connecting the motors directly to the pumps, engineers were able to remove the obsolete and troublesome clutch systems which had been controlling the flow of waste water.

AC890PX High Power Modular Systems Drives were installed in bottom entry configuration to provide stand-alone control of the pumps. The integrated line reactors also removed the need for expensive additional harmonic filters to be installed.

In addition to providing significant energy savings, the AC890PX installation has also reduced the overall maintenance costs of the system by reducing the mechanical stresses of the pumps during starting.

Benefits

- **Significant reduction in energy consumption**
- **Efficient speed control of pump drive motors**
- **Reduced wear and tear of mechanical components**
- **Reduced maintenance and increased system availability**
- **Integrated 3% line reactor removing the need for additional filtering**

Parker Drives Solution



AC890PX High Power Modular Drive

- High power ratings, can be configured for systems requiring 1MW and above
- Plug-in power modules for easy replacement
- Top or bottom cable entry provides flexibility in siting
- Available in 12 pulse, 18 pulse and AFE configurations
- Available in 400 VAC, 460 VAC, 575 VAC, and 690 VAC models

Worldwide Support

- Air-freightable plug-in power modules for improved availability and support
- Configurable to meet local requirements

Parker Worldwide

AE – UAE, Dubai

Tel: +971 4 8127100
parker.me@parker.com

AR – Argentina, Buenos Aires

Tel: +54 3327 44 4129

AT – Austria, Wiener Neustadt

Tel: +43 (0)2622 23501-0
parker.austria@parker.com

AT – Eastern Europe, Wiener Neustadt

Tel: +43 (0)2622 23501 900
parker.easteurope@parker.com

AU – Australia, Castle Hill

Tel: +61 (0)2-9634 7777

AZ – Azerbaijan, Baku

Tel: +994 50 2233 458
parker.azerbaijan@parker.com

BE/LU – Belgium, Nivelles

Tel: +32 (0)67 280 900
parker.belgium@parker.com

BR – Brazil, Cachoeirinha RS

Tel: +55 51 3470 9144

BY – Belarus, Minsk

Tel: +375 17 209 9399
parker.belarus@parker.com

CA – Canada, Milton, Ontario

Tel: +1 905 693 3000

CH – Switzerland, Etoy

Tel: +41 (0)21 821 87 00
parker.switzerland@parker.com

CL – Chile, Santiago

Tel: +56 2 623 1216

CN – China, Shanghai

Tel: +86 21 2899 5000

CZ – Czech Republic, Klecany

Tel: +420 284 083 111
parker.czechrepublic@parker.com

DE – Germany, Kaarst

Tel: +49 (0)2131 4016 0
parker.germany@parker.com

DK – Denmark, Ballerup

Tel: +45 43 56 04 00
parker.denmark@parker.com

ES – Spain, Madrid

Tel: +34 902 330 001
parker.spain@parker.com

FI – Finland, Vantaa

Tel: +358 (0)20 753 2500
parker.finland@parker.com

FR – France, Contamine s/Arve

Tel: +33 (0)4 50 25 80 25
parker.france@parker.com

GR – Greece, Athens

Tel: +30 210 933 6450
parker.greece@parker.com

HK – Hong Kong

Tel: +852 2428 8008

HU – Hungary, Budapest

Tel: +36 1 220 4155
parker.hungary@parker.com

IE – Ireland, Dublin

Tel: +353 (0)1 466 6370
parker.ireland@parker.com

IN – India, Mumbai

Tel: +91 22 6513 7081-85

IT – Italy, Corsico (MI)

Tel: +39 02 45 19 21
parker.italy@parker.com

JP – Japan, Tokyo

Tel: +81 (0)3 6408 3901

KR – South Korea, Seoul

Tel: +82 2 559 0400

KZ – Kazakhstan, Almaty

Tel: +7 7272 505 800
parker.easteurope@parker.com

LV – Latvia, Riga

Tel: +371 6 745 2601
parker.latvia@parker.com

MX – Mexico, Apodaca

Tel: +52 81 8156 6000

MY – Malaysia, Shah Alam

Tel: +60 3 7849 0800

NL – The Netherlands, Oldenzaal

Tel: +31 (0)541 585 000
parker.nl@parker.com

NO – Norway, Ski

Tel: +47 64 91 10 00
parker.norway@parker.com

NZ – New Zealand, Mt Wellington

Tel: +64 9 574 1744

PL – Poland, Warsaw

Tel: +48 (0)22 573 24 00
parker.poland@parker.com

PT – Portugal, Leca da Palmeira

Tel: +351 22 999 7360
parker.portugal@parker.com

RO – Romania, Bucharest

Tel: +40 21 252 1382
parker.romania@parker.com

RU – Russia, Moscow

Tel: +7 495 645-2156
parker.russia@parker.com

SE – Sweden, Spånga

Tel: +46 (0)8 59 79 50 00
parker.sweden@parker.com

SG – Singapore

Tel: +65 6887 6300

SK – Slovakia, Banská Bystrica

Tel: +421 484 162 252
parker.slovakia@parker.com

SL – Slovenia, Novo Mesto

Tel: +386 7 337 6650
parker.slovenia@parker.com

TH – Thailand, Bangkok

Tel: +662 717 8140

TR – Turkey, Istanbul

Tel: +90 216 4997081
parker.turkey@parker.com

TW – Taiwan, Taipei

Tel: +886 2 2298 8987

UA – Ukraine, Kiev

Tel: +380 44 494 2731
parker.ukraine@parker.com

UK – United Kingdom, Warwick

Tel: +44 (0)1926 317 878
parker.uk@parker.com

US – USA, Cleveland

Tel: +1 216 896 3000

VE – Venezuela, Caracas

Tel: +58 212 238 5422

ZA – South Africa, Kempton Park

Tel: +27 (0)11 961 0700
parker.southafrica@parker.com

