



# **Series 2AJ & 2ANJ**

## **Rod Lock Air Cylinders**

*Catalog HY08-0931-1/NA*  
*July, 2014*



**Benefits of using a piston Rod Lock include:**

- Prevents rod movement upon release of stored energy
- Eliminates the need for pilot operated check valves for load holding
- Eliminates complicated piping between pilot operated check valves and the cylinder

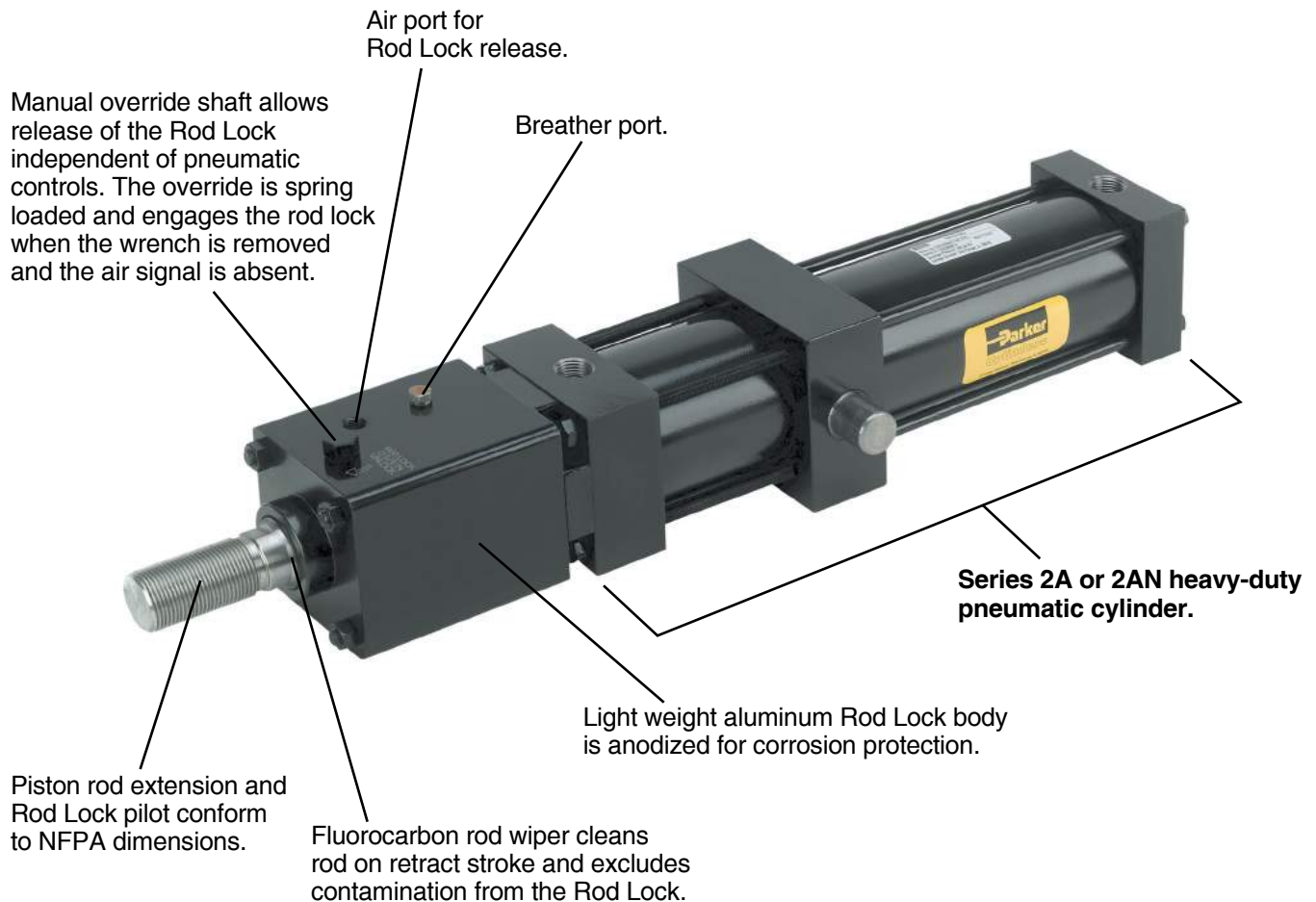

**Rod Lock Features**

- **True Bolt-on Modularity** – the cylinder is built and tested as a stand alone unit. The Rod Lock is then assembled and tested at rated holding force.
- **Large Rod Lock Clamping Surface** – provides uniform force to the rod contact area. This allows holding forces to resist 100 psi input on the cylinder cap end for most bore and rod combinations.
- **Spring-engaged, air-released operation** – ensures positive holding in power-off situations with minimal air volume required for release.
- **Manual release is standard** – cam operated release disengages the Rod Lock with a simple turn of a hex bolt. The default-to-lock function springs back to the engaged position when released.
- **Rod Lock is sealed to withstand harsh environments** – NEMA 4X rating protects internal components from contamination

<b>Table of Contents</b>	<b>Page No.</b>
Features, Benefits, Value .....	Inside Front Cover
How to Select a Cylinder.....	2
Theoretical Output.....	2
Rod Lock Rated Holding Force .....	2
Mounting Styles / Standard Specifications .....	3
Model Code .....	4
Rod Lock Specifications / Rod Lock Features.....	5
Connection of Rod Lock, Cylinder and Valve .....	5
Weight of Cylinder with Rod Lock .....	6
Cylinder Stroke Chart.....	7
Stop Tubing / Mounting Classes .....	8
T Mount Dimensions .....	10
TB, TC, TD Mount Dimensions .....	11
J Mount Dimensions .....	12
H Mount Dimensions.....	13
C Mount Dimensions.....	14
F Mount Dimensions .....	15
BB Mount Dimensions .....	16
SB Mount Dimensions .....	17
D Mount Dimensions.....	18
DB Mount Dimensions .....	19
DD Mount Dimensions.....	20
Double Rod End Dimensions .....	21
Style 55 Rod End Dimensions.....	22
Flange Coupler and Weld Plate Dimensions and Part Numbers .....	22
Mounting Accessories for Style SB .....	23
Mounting Accessories – Sizing & Dimensions for All Other Styles .....	24-25
Rod Lock Removal and Reinstallation / Torque Values .....	26
Service Parts Identification / Service Kits.....	27
Cylinder Safety Guide .....	28-29
Offer of Sale.....	32

 **Warning**

FAILURE OR IMPROPER SELECTION OR IMPROPER USE OF THE PRODUCTS AND/OR SYSTEMS DESCRIBED HEREIN OR RELATED ITEMS CAN CAUSE DEATH, PERSONAL INJURY AND PROPERTY DAMAGE.

This document and other information from Parker Hannifin Corporation, its subsidiaries and authorized distributors provide product and/or system options for further investigation by users having technical expertise. It is important that you analyze all aspects of your application, including consequences of any failure and review the information concerning the product or system in the current product catalog. Due to the variety of operating conditions and applications for these products or systems, the user, through its own analysis and testing, is solely responsible for making the final selection of the products and systems and assuring that all performance, safety and warning requirements of the application are met.

The product described herein, including without limitation, product features, specifications, designs, availability and pricing, are subject to change by Parker Hannifin Corporation and its subsidiaries at any time without notice.

**Offer of Sale**

The items described in this document are hereby offered for sale by Parker Hannifin Corporation, its subsidiaries or its authorized distributors. This offer and its acceptance are governed by provisions stated on a separate page of the document entitled 'Offer of Sale'.

**How to Select / Push & Pull Forces**

**How to Select a Series 2AJ or 2ANJ Cylinder**

Step 1 – **Determine the correct cylinder bore size** necessary to achieve required push or pull force using the available operating pressure (up to 100 psi). Follow steps in Theoretical Push and Pull Forces below.

Step 2 – **Select the mounting style** that fits your installation needs. Determine the bore and rod sizes available for the required mounting style and complete the model selection.

Step 3 – **Choose a rod end style** and the desired rod end accessories.

**Theoretical Push and Pull Forces**

The cylinder output forces are derived from this formula:

$$F = P \times A$$

Where F = Force in pounds.

P = Pressure at the cylinder in pounds per square inch.

A = Effective area of cylinder piston in square inches.

To determine the bore size for the application, follow the steps below.

1. Select the Operating Pressure column closest to that desired.

2. In the same column, identify the force required to move the load (always rounding up). If the piston rod is in compression use the 'Push' row and if the piston rod is in tension use the 'Pull' row.

3. In the row to the left is the bore required. To select the correct rod diameter for the stroke required use the Piston Rod-Stroke Selection Chart on page 7.

If the cylinder envelope dimensions are too large for the application, increase the operating pressure to the maximum pressure in the table below, if possible, and repeat steps 1 - 3.

**Push and Pull Force in Pounds**

Bore Ø	Rod Ø	Operating Direction	Piston Area (inches <sup>2</sup> )	Operating Pressure in psi		
				60	80	100
1 1/2	5/8	Push	1.767	106	141	177
		Pull	1.460	88	117	146
2	5/8	Push	3.142	189	251	314
		Pull	2.835	170	227	284
	1	Push	3.142	189	251	–
		Pull	2.357	141	189	–
2 1/2	5/8	Push	4.909	295	393	491
		Pull	4.602	276	368	460
	1	Push	4.909	295	393	491
		Pull	4.124	247	330	412
3 1/4	1	Push	8.296	498	664	830
		Pull	7.511	451	601	751
	1 3/8	Push	8.296	498	664	830
		Pull	6.811	409	545	681
	1 3/4	Push	8.296	498	664	830
		Pull	5.891	353	471	589
4	1	Push	12.566	754	1005	1257
		Pull	11.781	707	942	1178
	1 3/8	Push	12.566	754	1005	1257
		Pull	11.081	665	886	1108
	1 3/4	Push	12.566	754	1005	–
		Pull	10.161	610	813	–

Bore Ø	Rod Ø	Operating Direction	Piston Area (inches <sup>2</sup> )	Operating Pressure in psi		
				60	80	100
5	1	Push	19.635	1178	1571	1964
		Pull	18.850	1131	1508	1885
	1 3/8	Push	19.635	1178	1571	1964
		Pull	18.150	1089	1452	1815
6	1 3/4	Push	19.635	1178	1571	–
		Pull	17.230	1034	1378	–
	1 3/8	Push	28.274	1696	2262	2830
		Pull	26.789	1607	2143	2679
8	1 3/4	Push	28.274	1696	2264	2827
		Pull	25.869	1552	2070	2587
	2	Push	28.274	1696	2262	–
		Pull	25.132	1508	2011	–
8	1 3/8	Push	50.265	3016	4021	5027
		Pull	48.780	2927	3902	4878
	1 3/4	Push	50.265	3016	4021	5027
		Pull	47.860	2872	3829	4786
	2 1/2	Push	50.265	3016	4021	–
		Pull	45.365	2722	3629	–

**Cylinder Pressure Rating & Rod Lock Holding Force**

Bore Ø	1 1/2	2	2 1/2	3 1/4	4	5	6	8
Rod Ø	5/8	5/8	1	5/8, 1	1, 1 3/8	1, 1 3/8	1 3/4	1 3/8, 1 3/4
Cylinder Pressure Rating (psi)	100	100	80	100	100	80	100	80
Rod Lock Holding Force (lb.)	180	314	250	491	830	1256	1005	1963

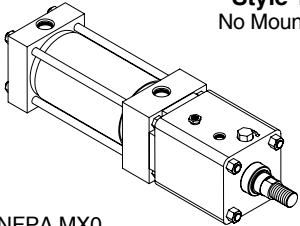
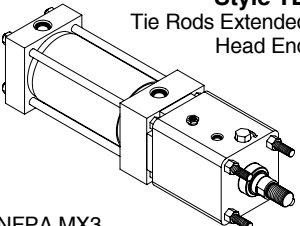
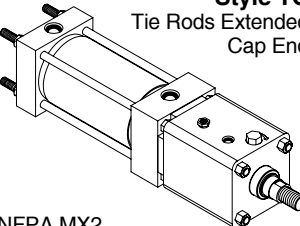
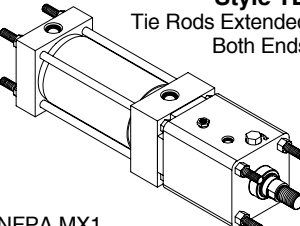
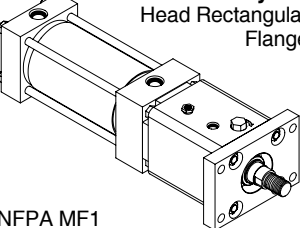
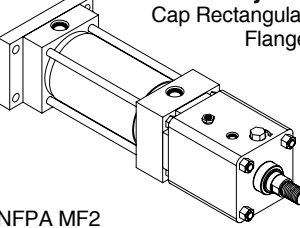
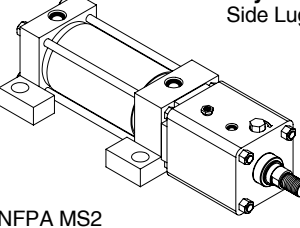
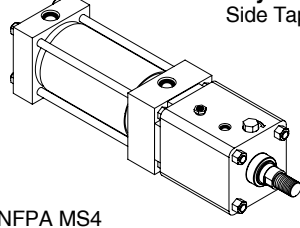
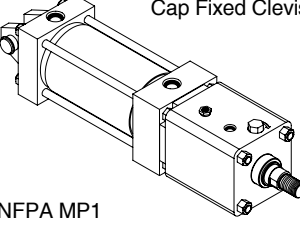
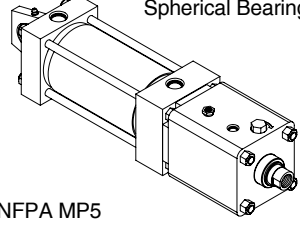
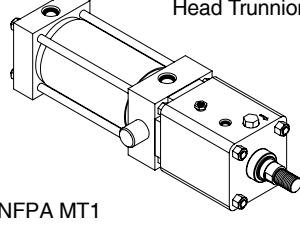
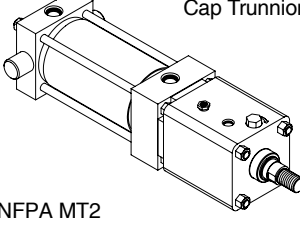
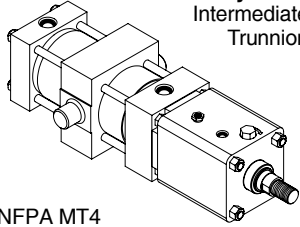

**Series 2AJ/2ANJ Mounting Styles**

 <p><b>Style T</b> No Mount</p> <p>NFPA MX0</p>	 <p><b>Style TB</b> Tie Rods Extended Head End</p> <p>NFPA MX3</p>	 <p><b>Style TC</b> Tie Rods Extended Cap End</p> <p>NFPA MX2</p>	 <p><b>Style TD</b> Tie Rods Extended Both Ends</p> <p>NFPA MX1</p>
 <p><b>Style J</b> Head Rectangular Flange</p> <p>NFPA MF1</p>	 <p><b>Style H</b> Cap Rectangular Flange</p> <p>NFPA MF2</p>	 <p><b>Style C</b> Side Lug</p> <p>NFPA MS2</p>	 <p><b>Style F</b> Side Tap</p> <p>NFPA MS4</p>
 <p><b>Style BB</b> Cap Fixed Clevis</p> <p>NFPA MP1</p>	 <p><b>Style SB</b> Spherical Bearing</p> <p>NFPA MP5</p>	 <p><b>Style D</b> Head Trunnion</p> <p>NFPA MT1</p>	 <p><b>Style DB</b> Cap Trunnion</p> <p>NFPA MT2</p>
 <p><b>Style DD</b> Intermediate Trunnion</p> <p>NFPA MT4</p>			

**Standard Specifications**

- 13 Standard mounting styles
- Bore sizes – 1½" to 8"
- Strokes – up to 120"
- Piston Rod Diameters – 5/8" to 2½"

- Working pressure up to 100 psi
- Single and double rod construction available
- Temperature range – -10°F (-23°C) to +165°F (+74°C) (depending on seal class)

Seal Classes	Typical Fluids	Temperature Range
1 – Standard Nitrile Seals	Dry 50µ filtered air	-10°F (-23°C) to +165°F (+74°C)
5 – Optional (At extra cost) Fluorocarbon Seals	Dry 50µ filtered air	-10°F (-23°C) to +165°F (+74°C)

Note: Class 5 seals do not increase temperature resistance of the cylinder and rock lock assembly. Specify Class 5 seals for chemical compatibility.

**2AJ / 2ANJ Model Code**

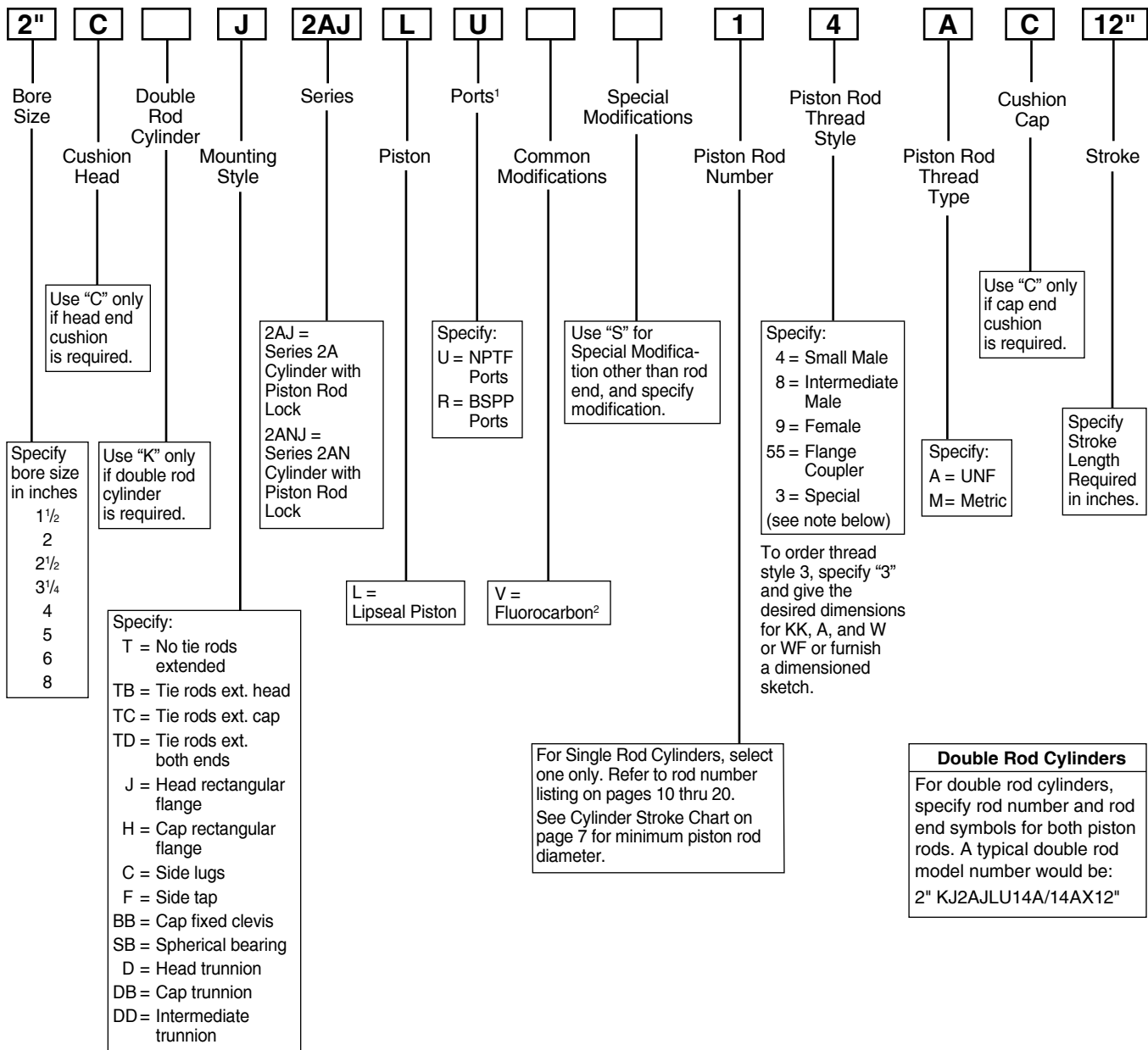

<sup>1</sup> Port thread styles for base cylinder only. Standard rod lock port is NPTF and cannot be specified with this field entry. If a different rod lock port is required, place an 'S' for special in the Special Modification field and indicate the desired rod lock port thread style in the item notes.

<sup>2</sup> Fluorocarbon seals for the 2AJ or 2ANJ are only for chemical compatibility and not for temperature resistance. The maximum rod lock operating temperature is +165°F.

**Rod Lock Connection / Rod Lock Specifications**

**Connection**

The Rod Lock release signal should be taken from the main air supply and must be **60 psi or higher**. Avoid using cylinder lines for the release signal because pressure levels may drop below the specified minimum. A separate quick-venting valve should be used for ON/OFF operation of the Rod Lock.

**Caution: Release pressures that fall below 60 psi may result in engagement of the rod lock.**

The Rod Lock is not intended to stop a moving load. The piston rod should not be moving when the Rod Lock release signal is removed.

Series 2AJ / 2ANJ is not intended for use in water service applications, environments with high humidity levels, or when fluids may splash on the cylinder or piston rod.

**Other Series 2AJ / 2ANJ and Rod Lock Features**

- The Rod Lock can be operated in both directions, engaging with the same holding force
- The Series 2AJ / 2ANJ can be mounted in any orientation. E.g. vertical, horizontal, rod up or down.
- The piston rod must not be rotated when the Rod Lock is engaged. The Rod Lock cannot be used for torsional braking.
- Rated Rod Lock holding force applies only to static load conditions. If the rated load value is exceeded, slippage and other problems (including damage to Rod Lock and piston rod) may occur.
- An unrelated, redundant safety system is recommended to help ensure personal safety.

**Sample Pneumatic Circuit**

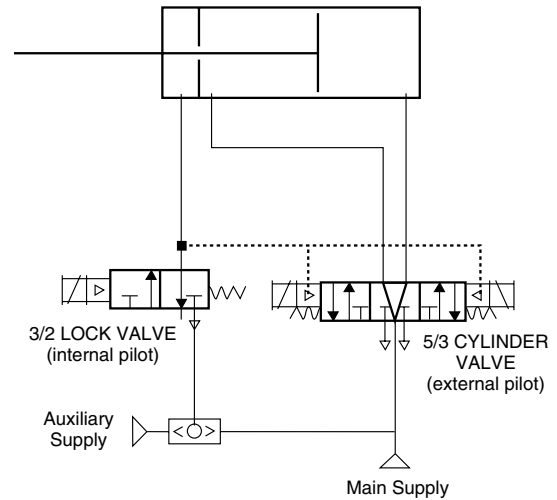

1. The Lock Valve must be energized during cylinder motion. When the Lock Valve is not energized, the Rod Lock is engaged and the Cylinder Valve must be in the mid-position.
2. The Cylinder Valve must be energized during extend or retract. It should also be energized at stroke end until a change of direction is required.
3. The 5/3 Cylinder Valve mid-position may be pressurized outlets if the combination of pressure load on the cylinder and the inertia effects of the attached load do not exceed the holding force rating of the rod lock device, including allowance for wear.
4. Do not use cylinder lines for logic functions because pressures can vary significantly.

**Rod Lock Specifications**

Bore Ø	Rod No.	Rod Ø	Air Chamber Volume (in <sup>3</sup> )	Rated Holding Force (lbs)	Minimum Override Torque (ft-lbs applied to hex shaft)	Cylinder Pressure Rating (psi)
1.50	1	0.625	0.25	180	2	100
2.00	1	0.625	0.71	314	5	100
	3	1.000	0.68	250	5	80
2.50	1	0.625	1.26	491	7	100
	3	1.000	1.49	491	7	100
3.25	1	1.000	3.20	830	17	100
	3	1.375	2.11	830	17	100
4.00	1	1.000	6.73	1256	45	100
	3	1.375	4.78	1256	45	100
	4	1.750	3.36	1005	45	80
5.00	1	1.000	11.50	1963	72	100
	3	1.375	9.50	1963	72	100
	4	1.750	8.28	1570	72	80
6.00	1	1.375	14.08	2830	135	100
	3	1.750	12.75	2830	135	100
	4	2.000	12.30	2264	135	80
8.00	1	1.375	22.66	5026	160	100
	3	1.750	23.21	5026	160	100
	5	2.500	17.53	4020	160	80

**Cylinder Weights**

To determine the weight of a Series 2AJ or 2ANJ cylinder, first select the basic zero stroke weight for the mounting required, and then calculate the weight of the cylinder stroke and add the results to the basic weight. For extra rod extension, use piston rod weights per inch in Table B.

**Table A – Series 2AJ & 2ANJ Cylinder Weights in Pounds**

Bore Ø	Rod Ø	Single Rod Cylinders Basic Weight - Zero Stroke		Add Per Inch of Stroke	Double Rod Cylinders Basic Weight - Zero Stroke		Add Per Inch of Stroke
		T, TB, TC, TD F, H, J	C, BB, SB D, DB, DD		KT, KTB, KTD KF, KJ	KC, KD, KDD	
1 1/2	5/8	6.0	6.6	0.30	6.5	7.1	0.60
2	5/8	10.0	10.4	0.50	11.7	12.1	1.00
	1	10.5	11.0	0.65	12.5	13.0	1.30
2 1/2	5/8	13.6	14.3	0.60	16.0	16.7	1.20
	1	14.1	14.6	0.75	16.6	17.1	1.50
3 1/4	1	24.6	25.6	0.80	30.1	31.1	1.60
	1 3/8	25.1	26.1	1.00	30.6	31.6	2.00
	1 3/4	25.9	26.9	1.25	32.2	33.2	2.50
4	1	38.7	43.7	1.00	45.7	50.7	2.00
	1 3/8	39.2	44.2	1.20	46.2	51.2	2.50
	1 3/4	40.0	45.0	1.50	47.8	52.8	3.00
5	1	56.3	63.3	1.10	65.3	72.3	2.20
	1 3/8	56.8	63.8	1.30	65.8	72.8	2.60
	1 3/4	57.6	64.6	1.55	67.4	74.4	3.10
6	1 3/8	104.8	113.8	1.50	116.8	125.8	3.00
	1 3/4	105.6	114.6	1.75	118.5	127.5	3.50
	2	106.3	115.3	2.00	120.0	129.0	4.00
8	1 3/8	158.4	163.4	2.00	172.4	177.4	4.00
	1 3/4	159.2	164.2	2.25	174.1	179.1	4.50
	2 1/2	161.7	166.7	3.00	179.1	184.1	6.00

**Table B – Piston Rod Weights in Pounds**

Rod Ø	Piston Rod Weight Per Inch
5/8"	0.09
1"	0.22
1 3/8"	0.42
1 3/4"	0.68
2"	0.89
2 1/2"	1.40



**Piston Rod — Stroke Selection Chart**

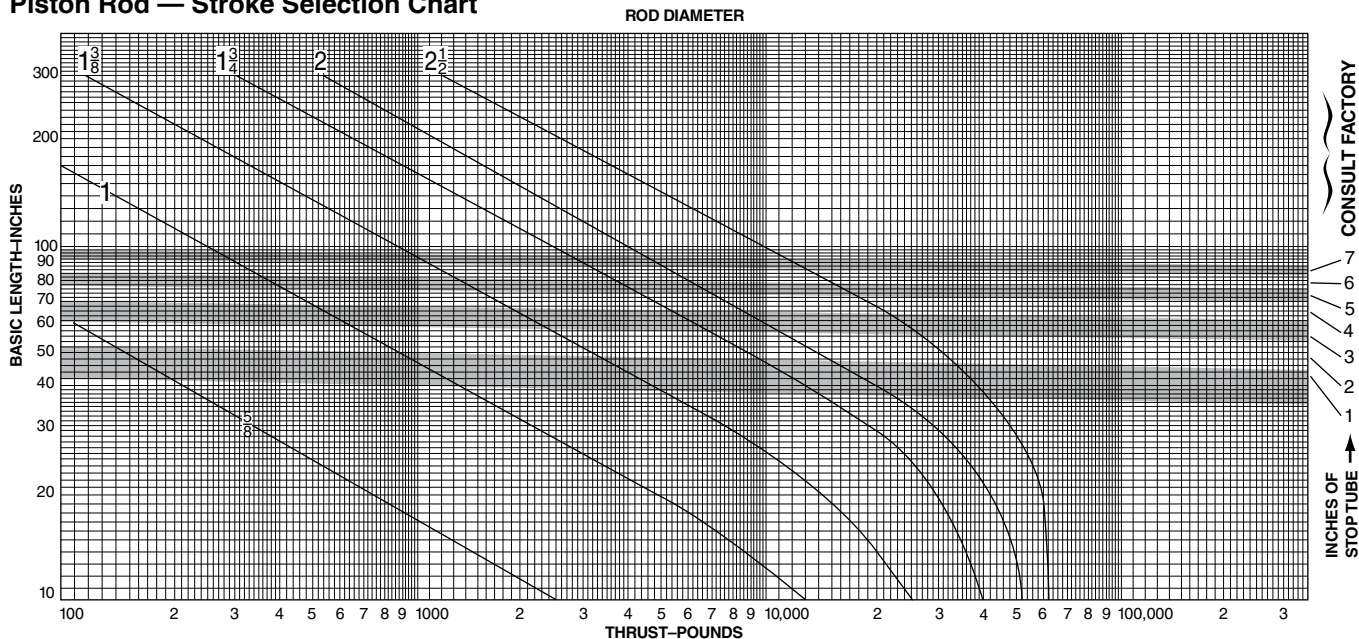

**How to Use the Chart**

The selection of a piston rod for thrust (push) conditions requires the following steps:

- Determine the type of cylinder mounting style and rod end connection to be used. Then consult the chart below and find the "stroke factor" that corresponds to the conditions used.
- Using this stroke factor, determine the "basic length" from the equation:  

$$\text{Basic Length} = \frac{\text{Actual Stroke}}{\text{Stroke Factor}}$$

The graph is prepared for standard rod extensions beyond the face of the head. For rod extensions greater than standard, add the increase to the stroke in arriving at the "basic length."
- Find the load imposed for the thrust application by multiplying the full bore area of the cylinder by the system pressure.
- Enter the graph along the values of "basic length" and "thrust" as found above and note the point of intersection:
  - The correct piston rod size is read from the diagonally curved line labeled "Rod Diameter" next *above* the point of intersection.
  - The required length of stop tube is read from the right of the graph by following the shaded band in which the point of intersection lies.

C) If required length of stop tube is in the region labeled "consult factory," submit the following information for an individual analysis:

- Cylinder mounting style.
- Rod end connection and method of guiding load.
- Bore, required stroke, length of rod extension (Dim. "A" and "W") if greater than standard, and series of cylinder used.
- Mounting position of cylinder. (Note: If at an angle or vertical, specify direction of piston rod.)
- Operating pressure of cylinder if limited to less than standard pressure for cylinder selected.

**Warning** ⚠

Piston rods are not normally designed to absorb bending moments or loads which are perpendicular to the axis of piston rod motion. These additional loads can cause the piston rod end to fail. If these types of additional loads are expected to be imposed on the piston rods, their magnitude should be made known to our Engineering Department so they may be properly addressed. Additionally, cylinder users should always make sure that the piston rod is securely attached to the machine member.

Recommended Mounting Styles for Maximum Stroke and Thrust Loads	Rod End Connection	Case	Stroke Factor
<b>Groups 1 or 3</b> Long stroke cylinders for thrust loads should be mounted using a heavy-duty mounting style at one end, firmly fixed and aligned to take the principal force. Additional mounting should be specified at the opposite end, which should be used for alignment and support. An intermediate support may also be desirable for long stroke cylinders mounted horizontally. Machine mounting pads can be adjustable for support mountings to achieve proper alignment.	Fixed and Rigidly Guided	I	.50
	Pivoted and Rigidly Guided	II	.70
	Supported but not Rigidly Guided	III	2.00
<b>Group 2</b> Style D — Trunnion on Head	Pivoted and Rigidly Guided	IV	1.00
Style DD — Intermediate Trunnion	Pivoted and Rigidly Guided	V	1.50
Style DB — Trunnion on Cap or Style BB — Clevis on Cap	Pivoted and Rigidly Guided	VI	2.00

**Stop Tubing**

Stop tube is recommended to lengthen the distance between the gland and piston to reduce bearing loads when the cylinder is fully extended. This is especially true of horizontally mounted and long stroke cylinders. Long stroke cylinders achieve additional stability through the use of a stop tube.

When specifying cylinders with long stroke and stop tube, be sure to call out the net stroke and the length of the stop tube. Machine design can be continued without delay by laying in a cylinder equivalent in length to the **NET STROKE PLUS STOP TUBE LENGTH**, which is referred to as **GROSS STROKE**.

Refer to piston rod/stroke selection chart to determine stop tube length.

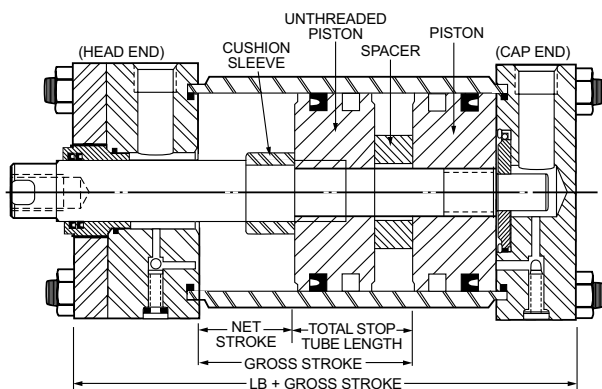

Double piston design is supplied on air cylinders with cushion head end or both ends.

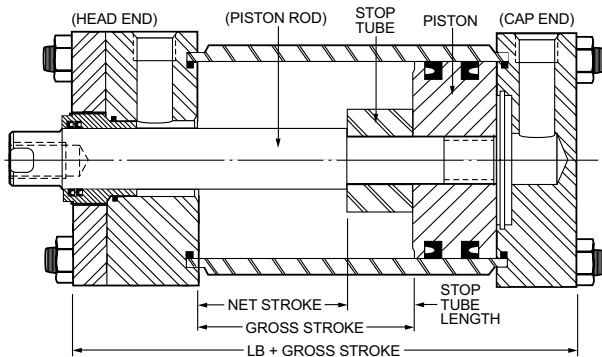

This design is supplied on cushion cap end non cushion cylinders.

**Mounting Classes**

Standard mountings for fluid power cylinders fall into three basic groups. The groups can be summarized as follows:

- Group 1 – Straight Line Force Transfer with fixed mounts which absorb force on cylinder centerline.
- Group 2 – Pivot Force Transfer. Pivot mountings permit a cylinder to change its alignment in one plane.
- Group 3 – Straight Line Force Transfer with fixed mounts which do not absorb force on cylinder centerline.

Because a cylinder's mounting directly affects the maximum pressure at which the cylinder can be used, the chart below should be helpful in selection of the proper mounting combination for your application. Stroke length, piston rod connection to load, extra piston rod length over standard, etc., should be considered for thrust loads. Alloy steel mounting bolts are recommended for all mounting styles, and thrust keys are recommended for Group 3.

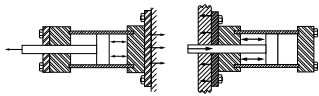
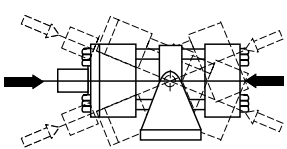
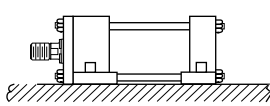
<b>Group 1</b> FIXED MOUNTS which absorb force on cylinder centerline.	
<p><b>Heavy-Duty Service</b> For Thrust Loads For Tension Loads</p>	 <p>Mtg. Style TC Mtg. Style TB</p>
<p><b>Medium-Duty Service</b> For Thrust Loads For Tension Loads</p>	<p>Mtg. Style H Mtg. Style J</p>
<b>Group 2</b> PIVOT MOUNTS which absorb force on cylinder centerline.	
<p><b>Heavy-Duty Service</b> For Thrust Loads For Tension Loads</p>	 <p>Mtg. Styles DD, D Mtg. Styles BB, DD, D, DB</p>
<p><b>Medium-Duty Service</b> For Thrust Loads For Tension Loads</p>	<p>Mtg. Style BB Mtg. Style BB</p>
<b>Group 3</b> FIXED MOUNTS which do not absorb force on the centerline.	
<p><b>Heavy-Duty Service</b> For Thrust Loads For Tension Loads</p>	 <p>Mtg. Style C Mtg. Style C</p>
<p><b>Medium-Duty Service</b> For Thrust Loads For Tension Loads</p>	<p>Mtg. Style F Mts. Style F</p>

## NOTES

**T Mount – Single Rod End**

1 1/2" to 8" Bore Size

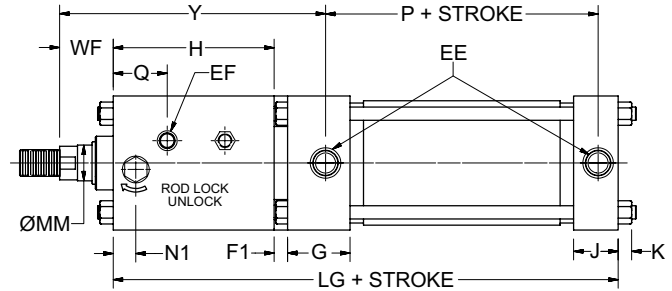
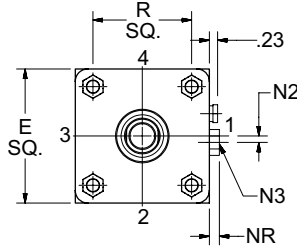
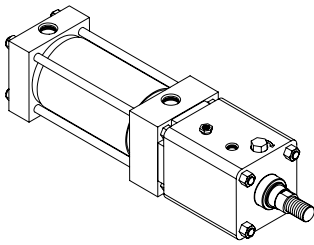

**T Mount Single Rod End – Envelope and Mounting Dimensions**

Bore Ø	E	EE NPTF	EF NPTF	F1	G	J	K	N3 Hex	NR (Max.)	R	P Add Stroke
1.50	2.00	3/8	1/8	0.25	1.50	1.00	0.25	5/16	0.24	1.43	2.25
2.00	2.50	3/8	1/8	0.31	1.50	1.00	0.32	1/2	0.32	1.84	2.25
2.50	3.00	3/8	1/8	0.31	1.50	1.00	0.32	1/2	0.32	2.19	2.38
3.25	3.75	1/2	1/4	0.38	1.75	1.25	0.38	5/8	0.41	2.76	2.63
4.00	4.50	1/2	1/4	0.38	1.75	1.25	0.38	7/8	0.55	3.32	2.63
5.00	5.50	1/2	1/4	0.50	1.75	1.25	0.44	7/8	0.55	4.10	2.88
6.00	6.50	3/4	1/4	0.50	2.00	1.50	0.44	1 5/16	0.81	4.88	3.13
8.00	8.50	3/4	1/4	0.63	2.00	1.50	0.56	1 5/16	0.81	6.44	3.25

**T Mount Single Rod End – Rod Dimensions**

Bore Ø	Rod No.	MM Rod Ø	Thread		Rod Extensions and Pilot Dimensions												LG Add Stroke
			CC Style 8	KK Style 4 & 9	A	B +.000 -0.002	C	D	H	N1	N2	NA	Q	VD	WF	Y	
1.50	1	0.625	1/2-20	7/16-20	0.75	1.124	0.38	0.50	2.63	0.22	0.14	0.56	0.72	0.38	1.00	4.81	6.50
	3	1.000	7/8-14	3/4-16	1.13	1.499	0.50	0.88	3.88	0.34	0.15	0.94	1.07	0.50	1.38	6.50	7.81
2.00	1	0.625	1/2-20	7/16-20	0.75	1.124	0.38	0.50	2.88	0.35	0.15	0.56	0.76	0.50	1.00	5.13	6.94
	3	1.000	7/8-14	3/4-16	1.13	1.499	0.50	0.88	4.00	0.35	0.15	0.94	1.12	0.50	1.38	6.63	8.06
2.50	1	0.625	1/2-20	7/16-20	0.75	1.124	0.38	0.50	2.88	0.35	0.15	0.56	0.76	0.50	1.00	5.13	6.94
	3	1.000	7/8-14	3/4-16	1.13	1.499	0.50	0.88	4.00	0.35	0.15	0.94	1.12	0.50	1.38	6.63	8.06
3.25	1	1.000	7/8-14	3/4-16	1.13	1.499	0.50	0.88	4.50	0.63	0.18	0.94	1.51	0.50	1.38	7.31	9.13
	3	1.375	1 1/4-12	1-14	1.63	1.999	0.63	1.13	4.88	0.81	0.25	1.31	1.65	0.63	1.63	7.94	9.50
4.00	1	1.000	7/8-14	3/4-16	1.13	1.499	0.50	0.88	4.88	0.63	0.24	0.94	1.73	0.50	1.38	7.69	9.50
	3	1.375	1 1/4-12	1-14	1.63	1.999	0.63	1.13	5.13	0.77	0.28	1.31	1.68	0.75	1.63	8.19	9.75
	4	1.750	1 1/2-12	1 1/4-12	2.00	2.374	0.75	1.50	5.50	1.03	0.26	1.69	2.09	0.88	1.88	8.81	10.13
5.00	1	1.000	7/8-14	3/4-16	1.13	1.499	0.50	0.88	5.38	0.72	0.22	0.94	2.00	0.50	1.38	8.31	10.38
	3	1.375	1 1/4-12	1-14	1.63	1.999	0.63	1.13	5.75	0.72	0.22	1.31	2.33	0.75	1.63	8.94	10.75
	4	1.750	1 1/2-12	1 1/4-12	2.00	2.374	0.75	1.50	6.38	1.10	0.22	1.69	2.30	0.88	1.88	9.81	11.38
6.00	1	1.375	1 1/4-12	1-14	1.63	1.999	0.63	1.13	6.38	1.17	0.18	1.31	2.71	0.76	1.63	9.69	11.88
	3	1.750	1 1/2-12	1 1/4-12	2.00	2.374	0.75	1.50	6.88	1.50	0.18	1.69	3.07	0.88	1.88	10.44	12.38
	4	2.000	1 3/4-12	1 1/2-12	2.25	2.624	0.88	1.69	7.00	1.49	0.18	1.94	3.18	1.25	2.00	10.69	12.50
8.00	1	1.375	1 1/4-12	1-14	1.63	1.999	0.63	1.13	6.63	1.31	0.18	1.31	2.89	0.76	1.63	10.06	12.38
	3	1.750	1 1/2-12	1 1/4-12	2.00	2.374	0.75	1.50	7.13	1.57	0.18	1.69	3.15	0.88	1.88	10.81	12.88
	5	2.500	2 1/4-12	1 7/8-12	3.00	3.124	1.00	2.06	7.50	1.22	0.30	2.38	3.15	1.38	2.25	11.56	13.25

**Rod End Dimensions**

**Thread Style 4**

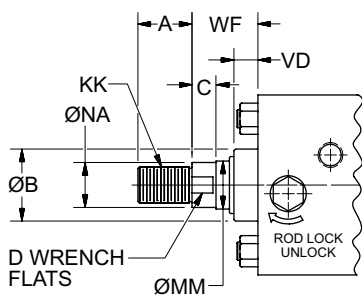

**Thread Style 8**

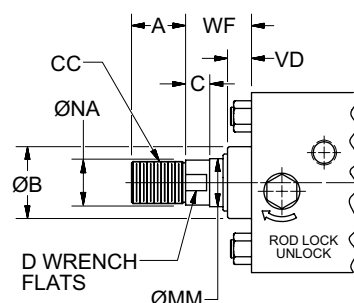

**Thread Style 9**

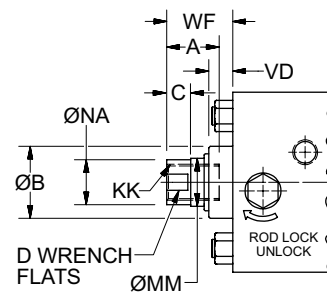

**“Special” Thread Style 3**

Special thread, extension, rod eye, blank, etc. are also available. To order, specify “Style 3” and give desired dimensions for KK, A, & WF. If otherwise special furnish dimensional sketch.

**TD Mount – Single Rod End\***

1½" to 8" Bore Size

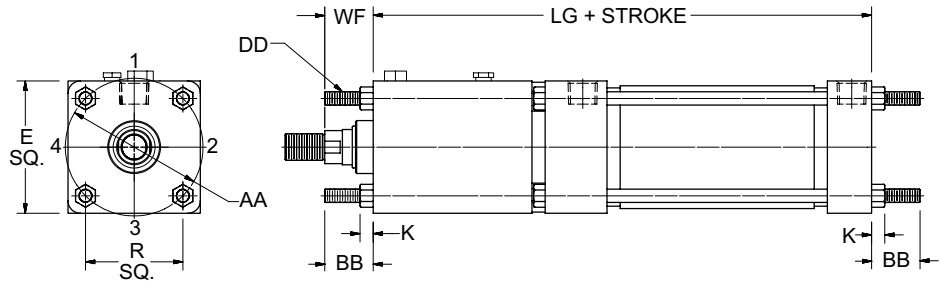
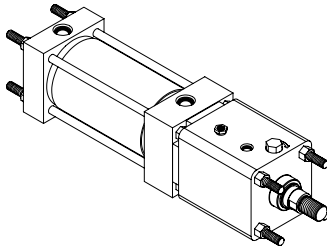

**TB, TC, TD Mount Single Rod End – Envelope and Mounting Dimensions**

Bore Ø	AA	BB	DD	E	K	R
1.50	2.02	1.00	1/4-28	2.00	0.25	1.43
2.00	2.60	1.13	5/16-24	2.50	0.31	1.84
2.50	3.10	1.13	5/16-24	3.00	0.31	2.19
3.25	3.90	1.38	3/8-24	3.75	0.38	2.76
4.00	4.70	1.38	3/8-24	4.50	0.38	3.32
5.00	5.80	1.81	1/2-20	5.50	0.44	4.10
6.00	6.90	1.81	1/2-20	6.50	0.44	4.88
8.00	9.10	2.31	5/8-18	8.50	0.31	6.44

\* Style TB – Tie Rods Extended Head End, and Style TC – Tie Rods Extended Cap End can be dimensioned from Style TD shown.

**TB, TC, TD Mount Single Rod End – Rod Dimensions**

Bore Ø	Rod No.	MM Rod Ø	Thread		Rod Extensions and Pilot Dimensions							LG Add Stroke
			CC Style 8	KK Style 4 & 9	A	B +.000 - .002	C	D	NA	VD	WF	
1.50	1	0.625	1/2-20	7/16-20	0.75	1.124	0.38	0.50	0.56	0.38	1.00	6.50
	3	1.000	7/8-14	3/4-16	1.13	1.499	0.50	0.88	0.94	0.50	1.38	7.81
2.00	1	0.625	1/2-20	7/16-20	0.75	1.124	0.38	0.50	0.56	0.38	1.00	6.81
	3	1.000	7/8-14	3/4-16	1.13	1.499	0.50	0.88	0.94	0.50	1.38	7.81
2.50	1	0.625	1/2-20	7/16-20	0.75	1.124	0.38	0.50	0.56	0.50	1.00	6.94
	3	1.000	7/8-14	3/4-16	1.13	1.499	0.50	0.88	0.94	0.50	1.38	8.06
3.25	1	1.000	7/8-14	3/4-16	1.13	1.499	0.50	0.88	0.94	0.50	1.38	9.13
	3	1.375	1 1/4-12	1-14	1.63	1.999	0.63	1.13	1.31	0.63	1.63	9.50
4.00	1	1.000	7/8-14	3/4-16	1.13	1.499	0.50	0.88	0.94	0.50	1.38	9.50
	3	1.375	1 1/4-12	1-14	1.63	1.999	0.63	1.13	1.31	0.75	1.63	9.75
	4	1.750	1 1/2-12	1 1/4-12	2.00	2.374	0.75	1.50	1.69	0.88	1.88	10.13
5.00	1	1.000	7/8-14	3/4-16	1.13	1.499	0.50	0.88	0.94	0.50	1.38	10.38
	3	1.375	1 1/4-12	1-14	1.63	1.999	0.63	1.13	1.31	0.75	1.63	10.75
	4	1.750	1 1/2-12	1 1/4-12	2.00	2.374	0.75	1.50	1.69	0.88	1.88	11.38
6.00	1	1.375	1 1/4-12	1-14	1.63	1.999	0.63	1.13	1.31	0.75	1.63	11.88
	3	1.750	1 1/2-12	1 1/4-12	2.00	2.374	0.75	1.50	1.69	0.88	1.88	12.38
	4	2.000	1 3/4-12	1 1/2-12	2.25	2.624	0.88	1.69	1.94	1.25	2.00	12.50
8.00	1	1.375	1 1/4-12	1-14	1.63	1.999	0.63	1.13	1.31	0.75	1.63	12.38
	3	1.750	1 1/2-12	1 1/4-12	2.00	2.374	0.75	1.50	1.69	0.88	1.88	12.88
	5	2.500	2 1/4-12	1 7/8-12	3.00	3.124	1.00	2.06	2.38	1.38	2.25	13.25

**Rod End Dimensions**

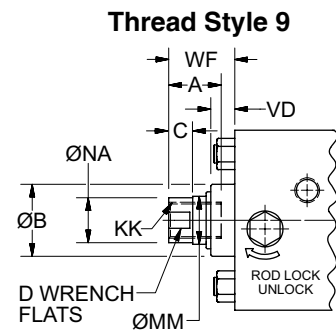
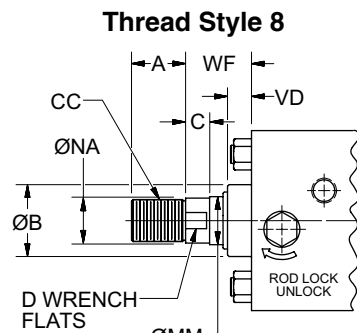
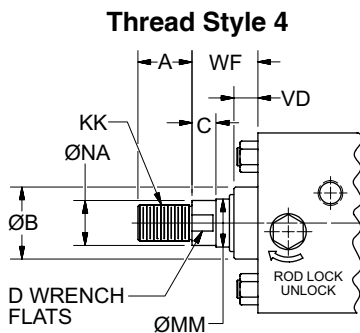

**“Special” Thread Style 3**

Special thread, extension, rod eye, blank, etc. are also available. To order, specify “Style 3” and give desired dimensions for KK, A, & WF. If otherwise special furnish dimensional sketch.

**J Mount – Single Rod End**

1 1/2" to 8" Bore Size

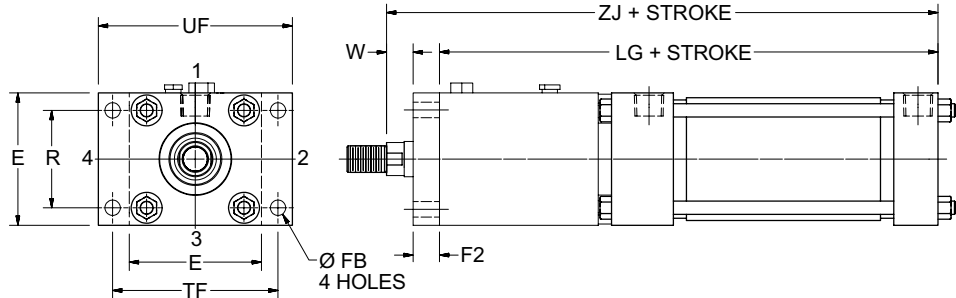
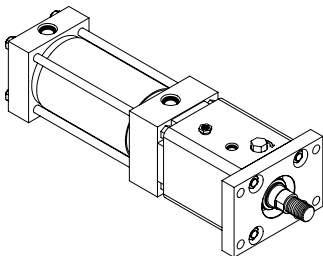

**J Mount Single Rod End – Envelope and Mounting Dimensions**

Bore Ø	E	F2	FB (Bolt)	R	TF	UF
1.50	2.00	0.63	0.25	1.43	2.75	3.38
2.00	2.50	0.63	0.31	1.84	3.38	4.13
2.50	3.00	0.63	0.31	2.19	3.88	4.63
3.25	3.75	0.75	0.38	2.76	4.69	5.50
4.00	4.50	0.75	0.38	3.32	5.44	6.25
5.00	5.50	0.75	0.50	4.10	6.63	7.63
6.00	6.50	0.75	0.50	4.88	7.63	8.63
8.00	8.50	1.00	0.63	6.44	9.75	11.00

**J Mount Single Rod End – Rod Dimensions**

Bore Ø	Rod No.	MM Rod Ø	Thread		Rod Extensions and Pilot Dimensions							Add Stroke	
			CC Style 8	KK Style 4 & 9	A	B +.000 -0.002	C	D	NA	V	W	LG	ZJ
1.50	1	0.625	1/2-20	7/16-20	0.75	1.124	0.38	0.50	0.56	-	0.63	6.50	7.75
2.00	1	0.625	1/2-20	7/16-20	0.75	1.124	0.38	0.50	0.56	-	0.63	6.81	8.06
	3	1.000	7/8-14	3/4-16	1.13	1.499	0.50	0.88	0.94	-	1.00	7.81	9.44
2.50	1	0.625	1/2-20	7/16-20	0.75	1.124	0.38	0.50	0.56	-	0.63	6.94	8.19
	3	1.000	7/8-14	3/4-16	1.13	1.499	0.50	0.88	0.94	-	1.00	8.06	9.69
3.25	1	1.000	7/8-14	3/4-16	1.13	1.499	0.50	0.88	0.94	-	0.75	9.13	10.63
	3	1.375	1 1/4-12	1-14	1.63	1.999	0.63	1.13	1.31	-	1.00	9.50	11.25
4.00	1	1.000	7/8-14	3/4-16	1.13	1.499	0.50	0.88	0.94	-	0.75	9.50	11.00
	3	1.375	1 1/4-12	1-14	1.63	1.999	0.63	1.13	1.31	-	1.00	9.75	11.50
	4	1.750	1 1/2-12	1 1/4-12	2.00	2.374	0.75	1.50	1.69	0.13	1.25	10.13	12.13
5.00	1	1.000	7/8-14	3/4-16	1.13	1.499	0.50	0.88	0.94	-	0.75	10.38	11.88
	3	1.375	1 1/4-12	1-14	1.63	1.999	0.63	1.13	1.31	-	1.00	10.75	12.50
	4	1.750	1 1/2-12	1 1/4-12	2.00	2.374	0.75	1.50	1.69	0.13	1.25	11.38	13.38
6.00	1	1.375	1 1/4-12	1-14	1.63	1.999	0.63	1.13	1.31	-	0.88	11.88	13.50
	3	1.750	1 1/2-12	1 1/4-12	2.00	2.374	0.75	1.50	1.69	0.13	1.13	12.38	14.25
	4	2.000	1 3/4-12	1 1/2-12	2.25	2.624	0.88	1.69	1.94	0.50	1.25	12.50	14.50
8.00	1	1.375	1 1/4-12	1-14	1.63	1.999	0.63	1.13	1.31	-	0.88	12.38	14.25
	3	1.750	1 1/2-12	1 1/4-12	2.00	2.374	0.75	1.50	1.69	-	1.13	12.88	15.00
	5	2.500	2 1/4-12	1 7/8-12	3.00	3.124	1.00	2.06	2.38	0.38	1.50	13.25	15.75

**Rod End Dimensions**

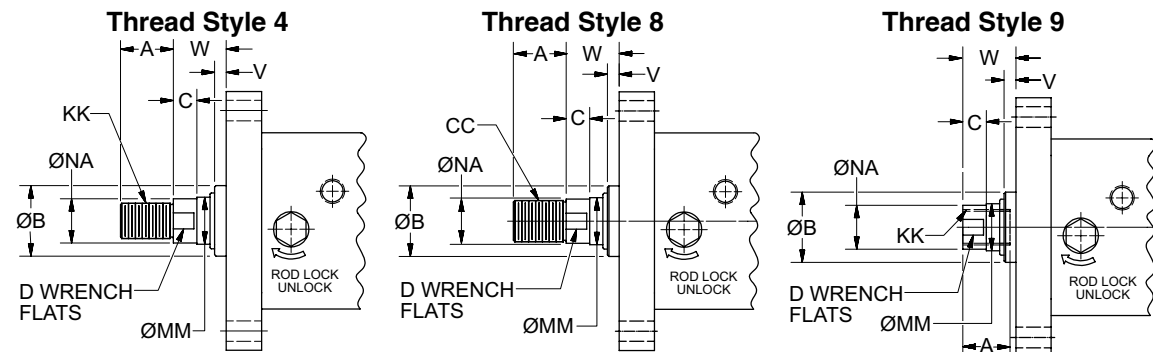

**“Special” Thread Style 3**  
 Special thread, extension, rod eye, blank, etc. are also available. To order, specify “Style 3” and give desired dimensions for KK, A, & W. If otherwise special furnish dimensional sketch.



**H Mount – Single Rod End**

1½" to 8" Bore Size

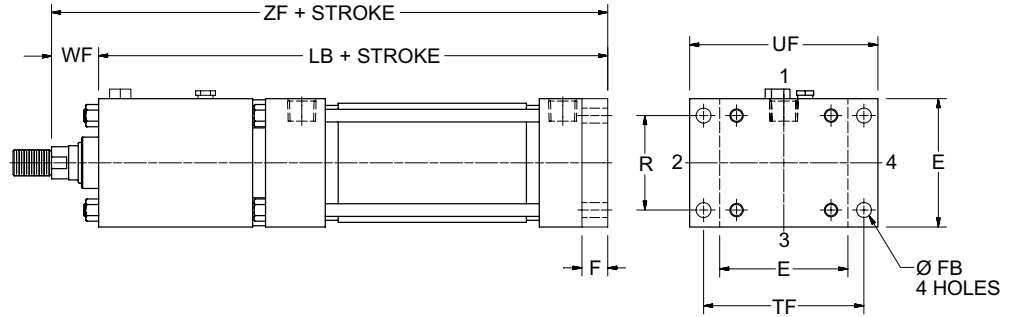
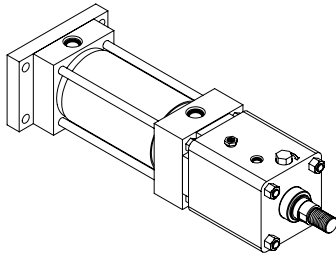

**H Mount Single Rod End – Envelope and Mounting Dimensions**

Bore Ø	E	F	FB (Bolt)	R	TF	UF
1.50	2.00	0.38	0.25	1.43	2.75	3.38
2.00	2.50	0.38	0.31	1.84	3.38	4.13
2.50	3.00	0.38	0.31	2.19	3.88	4.63
3.25	3.75	0.63	0.38	2.76	4.69	5.50
4.00	4.50	0.63	0.38	3.32	5.44	6.25
5.00	5.50	0.63	0.50	4.10	6.63	7.63
6.00	6.50	0.75	0.50	4.88	7.63	8.63
8.00	8.50	–	0.69*	7.57*	7.57*	8.50*

\* Style HB Square Cap mount supplied in 8" bore.

**H Mount Single Rod End – Rod Dimensions**

Bore Ø	Rod No.	MM Rod Ø	Thread		Rod Extensions and Pilot Dimensions							Add Stroke	
			CC Style 8	KK Style 4 & 9	A	B +.000 -0.002	C	D	NA	VD	WF	LB	ZF
1.50	1	0.625	1/2-20	7/16-20	0.75	1.124	0.38	0.50	0.56	0.38	1.00	6.88	7.88
2.00	1	0.625	1/2-20	7/16-20	0.75	1.124	0.38	0.50	0.56	0.38	1.00	7.19	8.19
	3	1.000	7/8-14	3/4-16	1.13	1.499	0.50	0.88	0.94	0.50	1.38	8.19	9.56
2.50	1	0.625	1/2-20	7/16-20	0.75	1.124	0.38	0.50	0.56	0.50	1.00	7.31	8.31
	3	1.000	7/8-14	3/4-16	1.13	1.499	0.50	0.88	0.94	0.50	1.38	8.44	9.81
3.25	1	1.000	7/8-14	3/4-16	1.13	1.499	0.50	0.88	0.94	0.50	1.38	9.75	11.13
	3	1.375	1 1/4-12	1-14	1.63	1.999	0.63	1.13	1.31	0.63	1.63	10.13	11.75
4.00	1	1.000	7/8-14	3/4-16	1.13	1.499	0.50	0.88	0.94	0.50	1.38	10.13	11.50
	3	1.375	1 1/4-12	1-14	1.63	1.999	0.63	1.13	1.31	0.75	1.63	10.38	12.00
	4	1.750	1 1/2-12	1 1/4-12	2.00	2.374	0.75	1.50	1.69	0.88	1.88	10.75	12.63
5.00	1	1.000	7/8-14	3/4-16	1.13	1.499	0.50	0.88	0.94	0.50	1.38	11.00	12.38
	3	1.375	1 1/4-12	1-14	1.63	1.999	0.63	1.13	1.31	0.75	1.63	11.38	13.00
	4	1.750	1 1/2-12	1 1/4-12	2.00	2.374	0.75	1.50	1.69	0.88	1.88	12.00	13.88
6.00	1	1.375	1 1/4-12	1-14	1.63	1.999	0.63	1.13	1.31	0.75	1.63	12.63	14.25
	3	1.750	1 1/2-12	1 1/4-12	2.00	2.374	0.75	1.50	1.69	0.88	1.88	13.13	15.00
	4	2.000	1 3/4-12	1 1/2-12	2.25	2.624	0.88	1.69	1.94	1.25	2.00	13.25	15.25
8.00	1	1.375	1 1/4-12	1-14	1.63	1.999	0.63	1.13	1.31	0.75	1.63	12.38*	14.00*
	3	1.750	1 1/2-12	1 1/4-12	2.00	2.374	0.75	1.50	1.69	0.88	1.88	12.88*	14.25*
	5	2.500	2 1/4-12	1 7/8-12	3.00	3.124	1.00	2.06	2.38	1.38	2.25	13.25*	15.50*

**Rod End Dimensions**

**Thread Style 4**

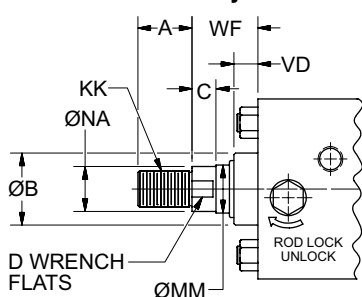

**Thread Style 8**

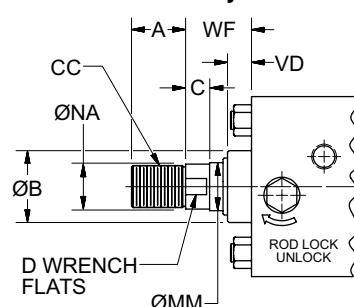

**Thread Style 9**

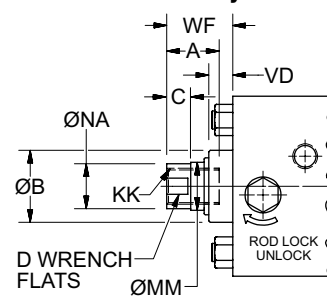

**“Special” Thread Style 3**

Special thread, extension, rod eye, blank, etc. are also available. To order, specify “Style 3” and give desired dimensions for KK, A, & WF. If otherwise special furnish dimensional sketch.

**C Mount – Single Rod End**

1½" to 8" Bore Size

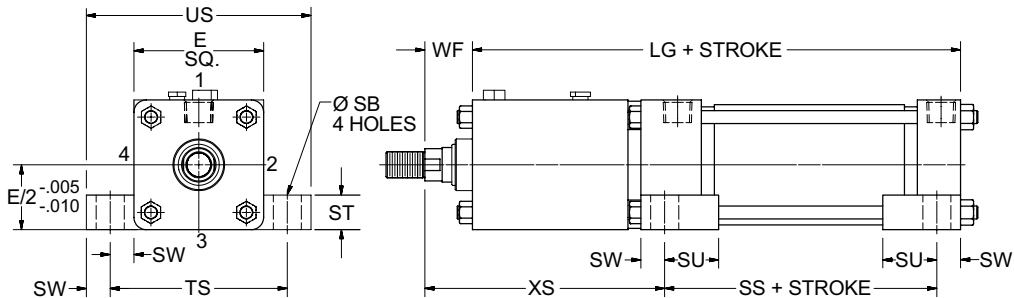
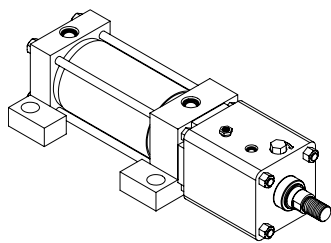

**C Mount Single Rod End – Envelope and Mounting Dimensions**

Bore Ø	E	SB (Bolt)	ST	SU	SW	TS	US	SS Add Stroke
1.50	2.00	0.38	0.50	0.94	0.38	2.75	3.50	2.88
2.00	2.50	0.38	0.50	0.94	0.38	3.25	4.00	2.88
2.50	3.00	0.38	0.50	0.94	0.38	3.75	4.50	3.00
3.25	3.75	0.50	0.75	1.25	0.50	4.75	5.75	3.25
4.00	4.50	0.50	0.75	1.25	0.50	5.50	6.50	3.25
5.00	5.50	0.75	1.00	1.56	0.69	6.88	8.25	3.13
6.00	6.50	0.75	1.00	1.56	0.69	7.88	9.25	3.63
8.00	8.50	0.75	1.00	1.56	0.69	9.88	11.25	3.75

**C Mount Single Rod End – Rod Dimensions**

Bore Ø	Rod No.	MM Rod Ø	Thread		Rod Extensions and Pilot Dimensions								LG Add Stroke
			CC Style 8	KK Style 4 & 9	A	B +.000 - .002	C	D	NA	VD	WF	XS	
1.50	1	0.625	1/2-20	7/16-20	0.75	1.124	0.38	0.50	0.56	0.38	1.00	4.25	6.50
2.00	1	0.625	1/2-20	7/16-20	0.75	1.124	0.38	0.50	0.56	0.38	1.00	4.56	6.81
	3	1.000	7/8-14	3/4-16	1.13	1.499	0.50	0.88	0.94	0.50	1.38	5.94	7.81
2.50	1	0.625	1/2-20	7/16-20	0.75	1.124	0.38	0.50	0.56	0.50	1.00	4.56	6.94
	3	1.000	7/8-14	3/4-16	1.13	1.499	0.50	0.88	0.94	0.50	1.38	6.06	8.06
3.25	1	1.000	7/8-14	3/4-16	1.13	1.499	0.50	0.88	0.94	0.50	1.38	6.75	9.13
	3	1.375	1 1/4-12	1-14	1.63	1.999	0.63	1.13	1.31	0.63	1.63	7.38	9.50
4.00	1	1.000	7/8-14	3/4-16	1.13	1.499	0.50	0.88	0.94	0.50	1.38	7.13	9.50
	3	1.375	1 1/4-12	1-14	1.63	1.999	0.63	1.13	1.31	0.75	1.63	7.63	9.75
	4	1.750	1 1/2-12	1 1/4-12	2.00	2.374	0.75	1.50	1.69	0.88	1.88	8.25	10.13
5.00	1	1.000	7/8-14	3/4-16	1.13	1.499	0.50	0.88	0.94	0.50	1.38	7.94	10.38
	3	1.375	1 1/4-12	1-14	1.63	1.999	0.63	1.13	1.31	0.75	1.63	8.56	10.75
	4	1.750	1 1/2-12	1 1/4-12	2.00	2.374	0.75	1.50	1.69	0.88	1.88	9.44	11.38
6.00	1	1.375	1 1/4-12	1-14	1.63	1.999	0.63	1.13	1.31	0.75	1.63	9.19	11.88
	3	1.750	1 1/2-12	1 1/4-12	2.00	2.374	0.75	1.50	1.69	0.88	1.88	9.94	12.38
	4	2.000	1 3/4-12	1 1/2-12	2.25	2.624	0.88	1.69	1.94	1.25	2.00	10.19	12.50
8.00	1	1.375	1 1/4-12	1-14	1.63	1.999	0.63	1.13	1.31	0.75	1.63	9.56	12.38
	3	1.750	1 1/2-12	1 1/4-12	2.00	2.374	0.75	1.50	1.69	0.88	1.88	10.31	12.88
	5	2.500	2 1/4-12	1 7/8-12	3.00	3.124	1.00	2.06	2.38	1.38	2.25	11.06	13.25

**Rod End Dimensions**

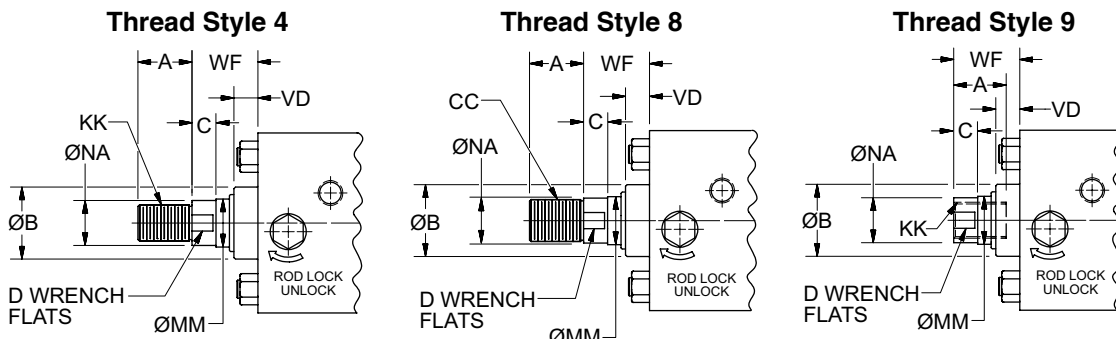

**“Special” Thread Style 3**

Special thread, extension, rod eye, blank, etc. are also available. To order, specify “Style 3” and give desired dimensions for KK, A, & WF. If otherwise special furnish dimensional sketch.



**F Mount – Single Rod End**

1½" to 8" Bore Size

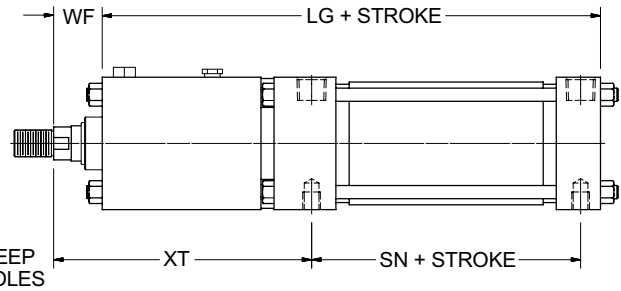
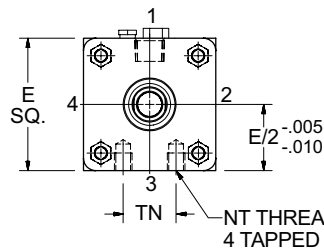
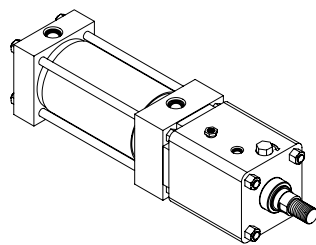

**F Mount Single Rod End – Envelope and Mounting Dimensions**

Bore Ø	E	ND	NT	TN	SN Add Stroke
1.50	2.00	0.31	1/4-20	0.63	2.25
2.00	2.50	0.34	5/16-18	0.88	2.25
2.50	3.00	0.44	3/8-16	1.25	2.38
3.25	3.75	0.50	1/2-13	1.50	2.63
4.00	4.50	0.63	1/2-13	2.06	2.63
5.00	5.50	0.75	5/8-11	2.69	2.88
6.00	6.50	0.88	3/4-10	3.25	3.13
8.00	8.50	1.13	3/4-10	4.25	3.25

**F Mount Single Rod End – Rod Dimensions**

Bore Ø	Rod No.	MM Rod Ø	Thread		Rod Extensions and Pilot Dimensions								LG Add Stroke
			CC Style 8	KK Style 4 & 9	A	B +.000 -.002	C	D	NA	VD	WF	XT	
1.50	1	0.625	1/2-20	7/16-20	0.75	1.124	0.38	0.50	0.56	0.38	1.00	4.81	6.50
2.00	1	0.625	1/2-20	7/16-20	0.75	1.124	0.38	0.50	0.56	0.38	1.00	5.13	6.81
	3	1.000	7/8-14	3/4-16	1.13	1.499	0.50	0.88	0.94	0.50	1.38	6.50	7.81
2.50	1	0.625	1/2-20	7/16-20	0.75	1.124	0.38	0.50	0.56	0.50	1.00	5.13	6.94
	3	1.000	7/8-14	3/4-16	1.13	1.499	0.50	0.88	0.94	0.50	1.38	6.63	8.06
3.25	1	1.000	7/8-14	3/4-16	1.13	1.499	0.50	0.88	0.94	0.50	1.38	7.31	9.13
	3	1.375	1 1/4-12	1-14	1.63	1.999	0.63	1.13	1.31	0.63	1.63	7.94	9.50
4.00	1	1.000	7/8-14	3/4-16	1.13	1.499	0.50	0.88	0.94	0.50	1.38	7.69	9.50
	3	1.375	1 1/4-12	1-14	1.63	1.999	0.63	1.13	1.31	0.75	1.63	8.19	9.75
	4	1.750	1 1/2-12	1 1/4-12	2.00	2.374	0.75	1.50	1.69	0.88	1.88	8.81	10.13
5.00	1	1.000	7/8-14	3/4-16	1.13	1.499	0.50	0.88	0.94	0.50	1.38	8.31	10.38
	3	1.375	1 1/4-12	1-14	1.63	1.999	0.63	1.13	1.31	0.75	1.63	8.94	10.75
	4	1.750	1 1/2-12	1 1/4-12	2.00	2.374	0.75	1.50	1.69	0.88	1.88	9.81	11.38
6.00	1	1.375	1 1/4-12	1-14	1.63	1.999	0.63	1.13	1.31	0.75	1.63	9.69	11.88
	3	1.750	1 1/2-12	1 1/4-12	2.00	2.374	0.75	1.50	1.69	0.88	1.88	10.44	12.38
	4	2.000	1 3/4-12	1 1/2-12	2.25	2.624	0.88	1.69	1.94	1.25	2.00	10.69	12.50
8.00	1	1.375	1 1/4-12	1-14	1.63	1.999	0.63	1.13	1.31	0.75	1.63	10.06	12.38
	3	1.750	1 1/2-12	1 1/4-12	2.00	2.374	0.75	1.50	1.69	0.88	1.88	10.81	12.88
	5	2.500	2 1/4-12	1 7/8-12	3.00	3.124	1.00	2.06	2.38	1.38	2.25	11.56	13.25

**Rod End Dimensions**

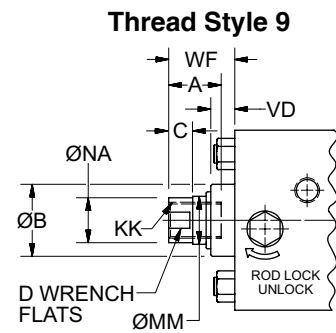
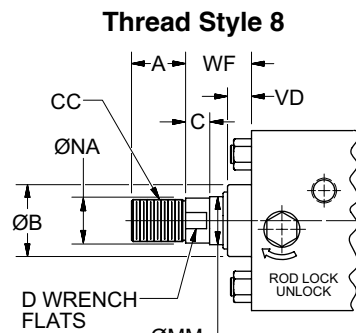
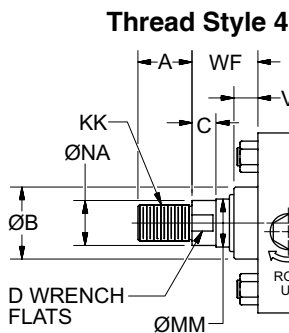

**“Special” Thread Style 3**  
 Special thread, extension, rod eye, blank, etc. are also available. To order, specify “Style 3” and give desired dimensions for KK, A, & WF. If otherwise special furnish dimensional sketch.

**BB Mount – Single Rod End**

1½" to 8" Bore Size

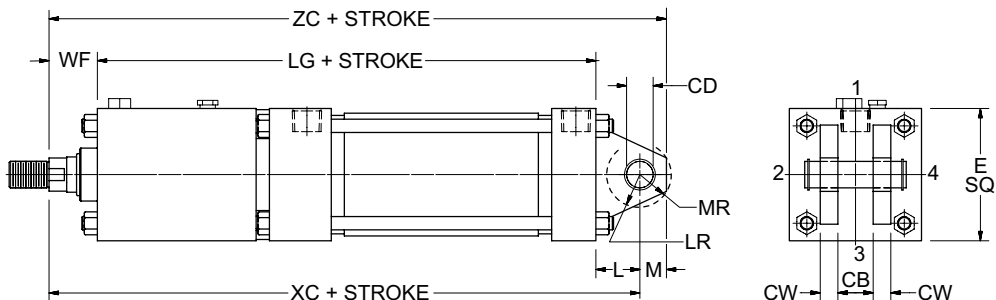
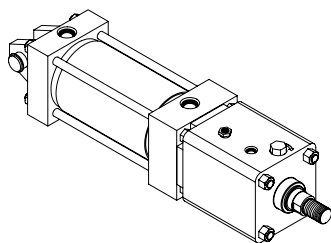

**BB Mount Single Rod End – Envelope and Mounting Dimensions**

Bore Ø	CB	CD * +0.000 -0.002	CW	E	L	LR	M	MR
1.50	0.75	0.501	0.50	2.00	0.75	0.75	0.50	0.63
2.00	0.75	0.501	0.50	2.50	0.75	0.75	0.50	0.63
2.50	0.75	0.501	0.50	3.00	0.75	0.75	0.50	0.63
3.25	1.25	0.751	0.63	3.75	1.25	1.00	0.75	0.94
4.00	1.25	0.751	0.63	4.50	1.25	1.00	0.75	0.94
5.00	1.25	0.751	0.63	5.50	1.25	1.00	0.75	0.94
6.00	1.50	1.001	0.75	6.50	1.50	1.25	1.00	1.19
8.00	1.50	1.001	0.75	8.50	1.50	1.25	1.00	1.19

\* Dimension CD is pin diameter.

**BB Mount Single Rod End – Rod Dimensions**

Bore Ø	Rod No.	MM Rod Ø	Thread		Rod Extensions and Pilot Dimensions							Add Stroke		
			CC Style 8	KK Style 4 & 9	A	B +0.000 -0.002	C	D	NA	VD	WF	LG	XC	ZC
1.50	1	0.625	1/2-20	7/16-20	0.75	1.124	0.38	0.50	0.56	0.38	1.00	6.50	8.25	8.75
	3	1.000	7/8-14	3/4-16	1.13	1.499	0.50	0.88	0.94	0.50	1.38	7.81	9.94	10.44
2.00	1	0.625	1/2-20	7/16-20	0.75	1.124	0.38	0.50	0.56	0.50	1.00	6.94	8.69	9.19
	3	1.000	7/8-14	3/4-16	1.13	1.499	0.50	0.88	0.94	0.50	1.38	8.06	10.19	10.69
2.50	1	0.625	1/2-20	7/16-20	0.75	1.124	0.38	0.50	0.56	0.50	1.00	6.94	8.69	9.19
	3	1.000	7/8-14	3/4-16	1.13	1.499	0.50	0.88	0.94	0.50	1.38	8.06	10.19	10.69
3.25	1	1.000	7/8-14	3/4-16	1.13	1.499	0.50	0.88	0.94	0.50	1.38	9.13	11.75	12.50
	3	1.375	1 1/4-12	1-14	1.63	1.999	0.63	1.13	1.31	0.63	1.63	9.50	12.38	13.13
4.00	1	1.000	7/8-14	3/4-16	1.13	1.499	0.50	0.88	0.94	0.50	1.38	9.50	12.13	12.88
	3	1.375	1 1/4-12	1-14	1.63	1.999	0.63	1.13	1.31	0.75	1.63	9.75	12.63	13.38
	4	1.750	1 1/2-12	1 1/4-12	2.00	2.374	0.75	1.50	1.69	0.88	1.88	10.13	13.25	14.00
5.00	1	1.000	7/8-14	3/4-16	1.13	1.499	0.50	0.88	0.94	0.50	1.38	10.38	13.00	13.75
	3	1.375	1 1/4-12	1-14	1.63	1.999	0.63	1.13	1.31	0.75	1.63	10.75	13.63	14.38
	4	1.750	1 1/2-12	1 1/4-12	2.00	2.374	0.75	1.50	1.69	0.88	1.88	11.38	14.50	15.25
6.00	1	1.375	1 1/4-12	1-14	1.63	1.999	0.63	1.13	1.31	0.75	1.63	11.88	15.00	16.00
	3	1.750	1 1/2-12	1 1/4-12	2.00	2.374	0.75	1.50	1.69	0.88	1.88	12.38	15.75	16.75
	4	2.000	1 3/4-12	1 1/2-12	2.25	2.624	0.88	1.69	1.94	1.25	2.00	12.50	16.00	17.00
8.00	1	1.375	1 1/4-12	1-14	1.63	1.999	0.63	1.13	1.31	0.75	1.63	12.38	15.50	16.50
	3	1.750	1 1/2-12	1 1/4-12	2.00	2.374	0.75	1.50	1.69	0.88	1.88	12.88	16.25	17.25
	5	2.500	2 1/4-12	1 7/8-12	3.00	3.124	1.00	2.06	2.38	1.38	2.25	13.25	17.00	18.00

**Rod End Dimensions**

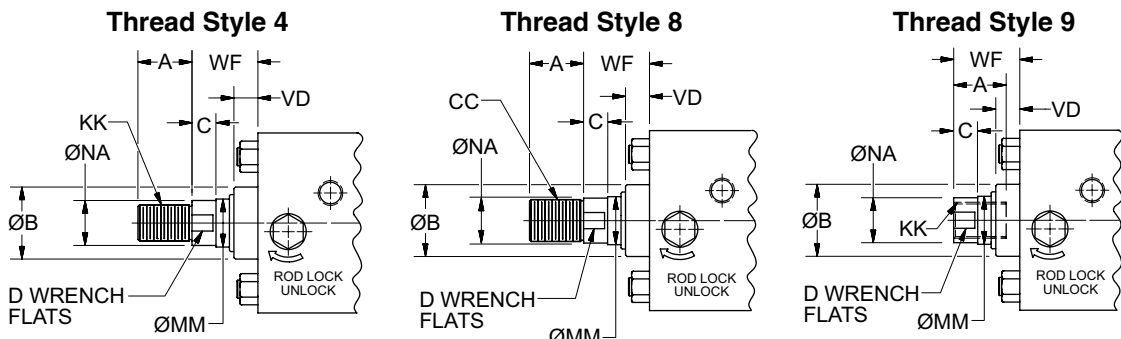

**“Special” Thread Style 3**  
 Special thread, extension, rod eye, blank, etc. are also available. To order, specify “Style 3” and give desired dimensions for KK, A, & WF. If otherwise special furnish dimensional sketch.



**SB Mount – Single Rod End**

1 1/2" to 8" Bore Size

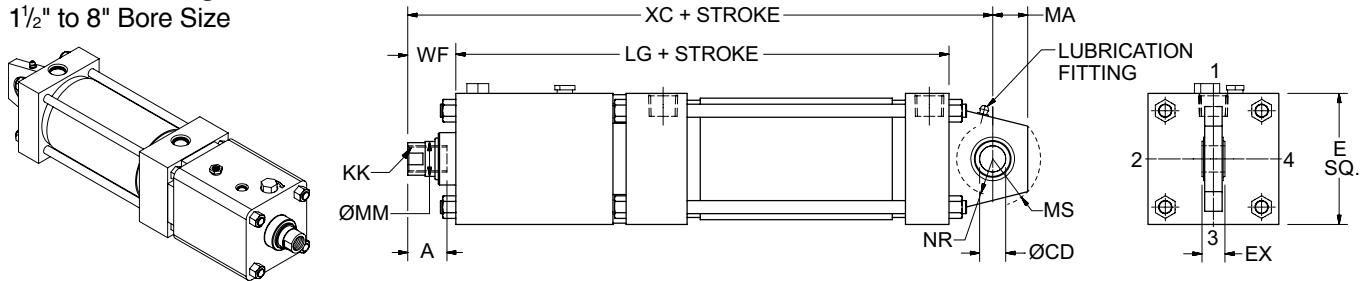

**SB Mount Single Rod End – Envelope and Mounting Dimensions**

Bore Ø	CD * +0.000 -0.005	E	EX	MA	MS	NR
1.50	0.5000	2.00	0.44	0.75	0.94	0.63
2.00	0.5000	2.50	0.44	0.75	0.94	0.63
2.50	0.5000	3.00	0.44	0.75	0.94	0.63
3.25	0.7500	3.75	0.66	1.00	1.38	1.00
4.00	0.7500	4.50	0.66	1.00	1.38	1.00
5.00	0.7500	5.50	0.66	1.00	1.38	1.00
6.00	1.0000	6.50	0.88	1.25	1.69	1.25
8.00	1.0000	8.50	0.88	1.25	1.69	1.25

\* Dimension CD is hole diameter.

**SB Mount Single Rod End – Rod Dimensions**

Bore Ø	Rod No.	MM Rod Ø	Thread		A	WF	Add Stroke	
			KK Style 9	KK Style 7			LG	XC
1.50	1	0.625	7/16-20	–	0.75	1.00	6.50	8.25
2.00	1	0.625	7/16-20	–	0.75	1.00	6.81	8.56
	3	1.000	–	7/16-20	1.13	1.38	7.81	9.94
2.50	1	0.625	7/16-20	–	0.75	1.00	6.94	8.69
	3	1.000	–	7/16-20	1.13	1.38	8.06	10.19
3.25	1	1.000	3/4-16	–	1.13	1.38	9.13	11.75
	3	1.375	–	3/4-16	1.63	1.63	9.50	12.38
4.00	1	1.000	3/4-16	–	1.13	1.38	9.50	12.13
	3	1.375	–	3/4-16	1.63	1.63	9.75	12.63
	4	1.750	–	3/4-16	2.00	1.88	10.13	13.25
5.00	1	1.000	3/4-16	–	1.13	1.38	10.38	13.00
	3	1.375	–	3/4-16	1.63	1.63	10.75	13.63
	4	1.750	–	3/4-16	2.00	1.88	11.38	14.50
6.00	1	1.375	1-14	–	1.63	1.63	11.88	15.00
	3	1.750	–	1-14	2.00	1.88	12.38	15.75
	4	2.000	–	1-14	2.25	2.00	12.50	16.00
8.00	1	1.375	1-14	–	1.63	1.63	12.38	15.50
	3	1.750	–	1-14	2.00	1.88	12.88	16.25
	5	2.500	–	1-14	3.00	2.25	13.25	17.00

**D Mount – Single Rod End**

**D Mount – Single Rod End**  
1½" to 8" Bore Size

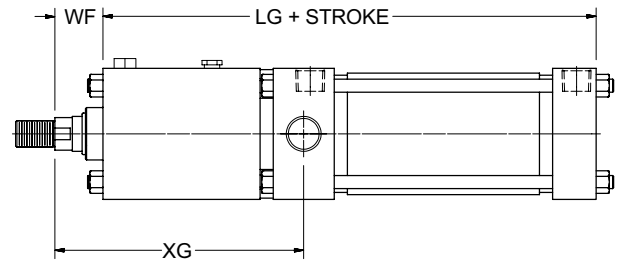
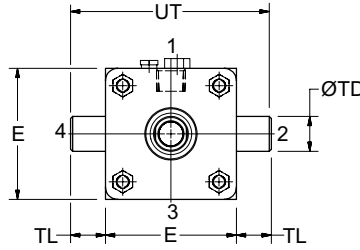
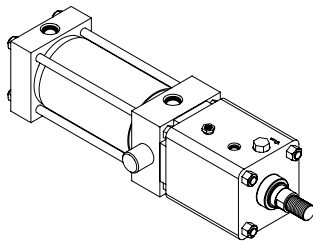

**D Mount Single Rod End – Envelope and Mounting Dimensions**

Bore Ø	E	TD +0.000 -0.001	TL	UT
1.50	2.00	1.000	1.00	4.00
2.00	2.50	1.000	1.00	4.50
2.50	3.00	1.000	1.00	5.00
3.25	3.75	1.000	1.00	5.75
4.00	4.50	1.000	1.00	6.50
5.00	5.50	1.000	1.00	7.50
6.00	6.50	1.375	1.38	9.25
8.00	8.50	1.375	1.38	11.25

**D Mount Single Rod End – Rod Dimensions**

Bore Ø	Rod No.	MM Rod Ø	Thread		Rod Extensions and Pilot Dimensions								LG Add Stroke
			CC Style 8	KK Style 4 & 9	A	B +0.000 -0.002	C	D	NA	VD	WF	XG	
1.50	1	0.625	1/2-20	7/16-20	0.75	1.124	0.38	0.50	0.56	0.38	1.00	4.63	6.50
2.00	1	0.625	1/2-20	7/16-20	0.75	1.124	0.38	0.50	0.56	0.38	1.00	4.94	6.81
	3	1.000	7/8-14	3/4-16	1.13	1.499	0.50	0.88	0.94	0.50	1.38	6.31	7.81
2.50	1	0.625	1/2-20	7/16-20	0.75	1.124	0.38	0.50	0.56	0.50	1.00	4.94	6.94
	3	1.000	7/8-14	3/4-16	1.13	1.499	0.50	0.88	0.94	0.50	1.38	6.44	8.06
3.25	1	1.000	7/8-14	3/4-16	1.13	1.499	0.50	0.88	0.94	0.50	1.38	7.13	9.13
	3	1.375	1 1/4-12	1-14	1.63	1.999	0.63	1.13	1.31	0.63	1.63	7.75	9.50
4.00	1	1.000	7/8-14	3/4-16	1.13	1.499	0.50	0.88	0.94	0.50	1.38	7.50	9.50
	3	1.375	1 1/4-12	1-14	1.63	1.999	0.63	1.13	1.31	0.75	1.63	8.00	9.75
	4	1.750	1 1/2-12	1 1/4-12	2.00	2.374	0.75	1.50	1.69	0.88	1.88	8.63	10.13
5.00	1	1.000	7/8-14	3/4-16	1.13	1.499	0.50	0.88	0.94	0.50	1.38	8.13	10.38
	3	1.375	1 1/4-12	1-14	1.63	1.999	0.63	1.13	1.31	0.75	1.63	8.75	10.75
	4	1.750	1 1/2-12	1 1/4-12	2.00	2.374	0.75	1.50	1.69	0.88	1.88	9.63	11.38
6.00	1	1.375	1 1/4-12	1-14	1.63	1.999	0.63	1.13	1.31	0.75	1.63	9.50	11.88
	3	1.750	1 1/2-12	1 1/4-12	2.00	2.374	0.75	1.50	1.69	0.88	1.88	10.25	12.38
	4	2.000	1 3/4-12	1 1/2-12	2.25	2.624	0.88	1.69	1.94	1.25	2.00	10.50	12.50
8.00	1	1.375	1 1/4-12	1-14	1.63	1.999	0.63	1.13	1.31	0.75	1.63	9.88	12.38
	3	1.750	1 1/2-12	1 1/4-12	2.00	2.374	0.75	1.50	1.69	0.88	1.88	10.63	12.88
	5	2.500	2 1/4-12	1 7/8-12	3.00	3.124	1.00	2.06	2.38	1.38	2.25	11.38	13.25

**Rod End Dimensions**

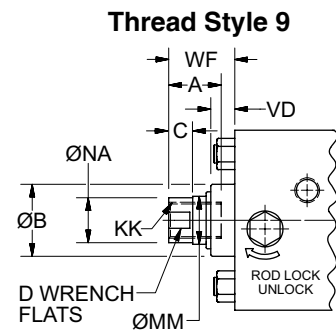
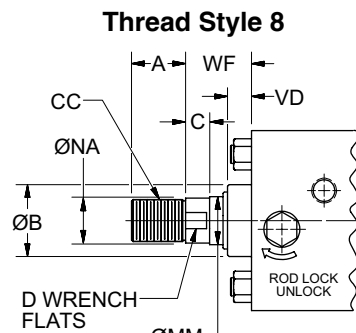
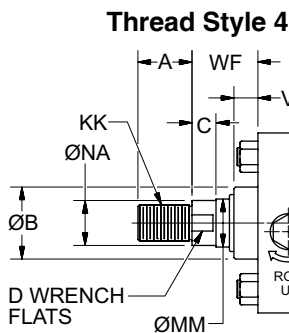

**“Special” Thread Style 3**  
Special thread, extension, rod eye, blank, etc. are also available. To order, specify “Style 3” and give desired dimensions for KK, A, & WF. If otherwise special furnish dimensional sketch.



**DB Mount – Single Rod End**

1½" to 8" Bore Size

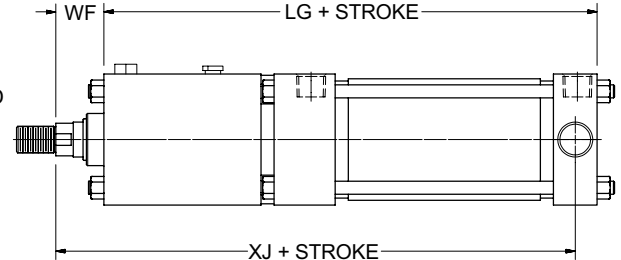
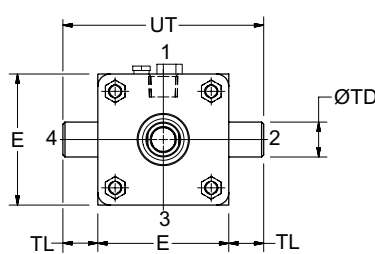
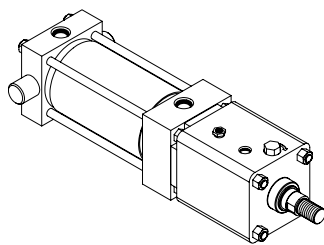

**DB Mount Single Rod End – Envelope and Mounting Dimensions**

Bore Ø	E	TD +.000 -.001	TL	UT
1.50	2.00	1.000	1.00	4.00
2.00	2.50	1.000	1.00	4.50
2.50	3.00	1.000	1.00	5.00
3.25	3.75	1.000	1.00	5.75
4.00	4.50	1.000	1.00	6.50
5.00	5.50	1.000	1.00	7.50
6.00	6.50	1.375	1.38	9.25
8.00	8.50	1.375	1.38	11.25

**DB Mount Single Rod End – Rod Dimensions**

Bore Ø	Rod No.	MM Rod Ø	Thread		Rod Extensions and Pilot Dimensions							Add Stroke	
			CC Style 8	KK Style 4 & 9	A	B +.000 -.002	C	D	NA	VD	WF	LG	XJ
1.50	1	0.625	1/2-20	7/16-20	0.75	1.124	0.38	0.50	0.56	0.38	1.00	6.50	7.00
2.00	1	0.625	1/2-20	7/16-20	0.75	1.124	0.38	0.50	0.56	0.38	1.00	6.81	7.31
	3	1.000	7/8-14	3/4-16	1.13	1.499	0.50	0.88	0.94	0.50	1.38	7.81	8.69
2.50	1	0.625	1/2-20	7/16-20	0.75	1.124	0.38	0.50	0.56	0.50	1.00	6.94	7.44
	3	1.000	7/8-14	3/4-16	1.13	1.499	0.50	0.88	0.94	0.50	1.38	8.06	8.94
3.25	1	1.000	7/8-14	3/4-16	1.13	1.499	0.50	0.88	0.94	0.50	1.38	9.13	9.88
	3	1.375	1 1/4-12	1-14	1.63	1.999	0.63	1.13	1.31	0.63	1.63	9.50	10.50
4.00	1	1.000	7/8-14	3/4-16	1.13	1.499	0.50	0.88	0.94	0.50	1.38	9.50	10.25
	3	1.375	1 1/4-12	1-14	1.63	1.999	0.63	1.13	1.31	0.75	1.63	9.75	10.75
	4	1.750	1 1/2-12	1 1/4-12	2.00	2.374	0.75	1.50	1.69	0.88	1.88	10.13	11.38
5.00	1	1.000	7/8-14	3/4-16	1.13	1.499	0.50	0.88	0.94	0.50	1.38	10.38	11.13
	3	1.375	1 1/4-12	1-14	1.63	1.999	0.63	1.13	1.31	0.75	1.63	10.75	11.75
	4	1.750	1 1/2-12	1 1/4-12	2.00	2.374	0.75	1.50	1.69	0.88	1.88	11.38	12.63
6.00	1	1.375	1 1/4-12	1-14	1.63	1.999	0.63	1.13	1.31	0.75	1.63	11.88	12.75
	3	1.750	1 1/2-12	1 1/4-12	2.00	2.374	0.75	1.50	1.69	0.88	1.88	12.38	13.50
	4	2.000	1 3/4-12	1 1/2-12	2.25	2.624	0.88	1.69	1.94	1.25	2.00	12.50	13.75
8.00	1	1.375	1 1/4-12	1-14	1.63	1.999	0.63	1.13	1.31	0.75	1.63	12.38	13.25
	3	1.750	1 1/2-12	1 1/4-12	2.00	2.374	0.75	1.50	1.69	0.88	1.88	12.88	14.00
	5	2.500	2 1/4-12	1 7/8-12	3.00	3.124	1.00	2.06	2.38	1.38	2.25	13.25	14.75

**Rod End Dimensions**

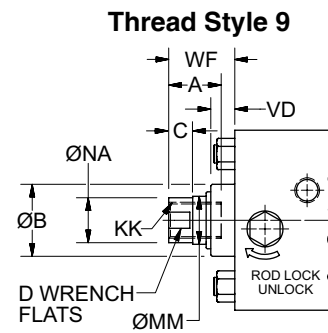
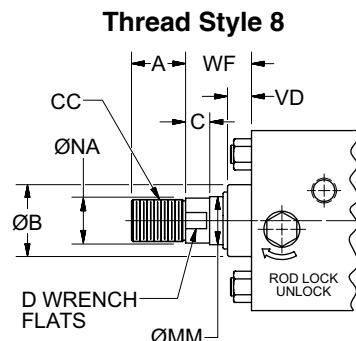
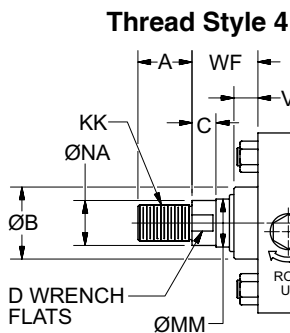

**“Special” Thread Style 3**  
 Special thread, extension, rod eye, blank, etc. are also available. To order, specify “Style 3” and give desired dimensions for KK, A, & WF. If otherwise special furnish dimensional sketch.

**DD Mount – Single Rod End**

1½" to 8" Bore Size

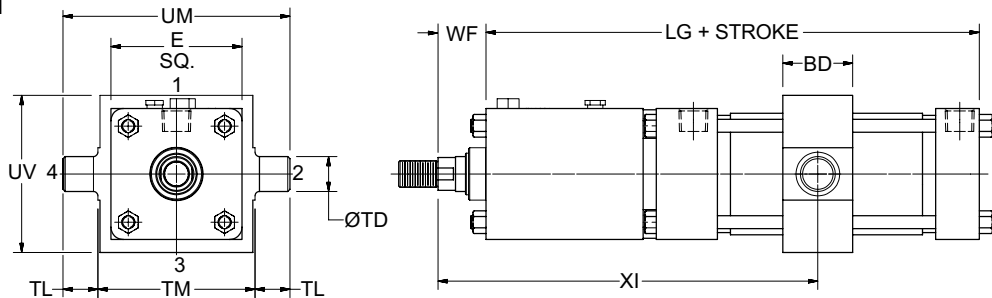
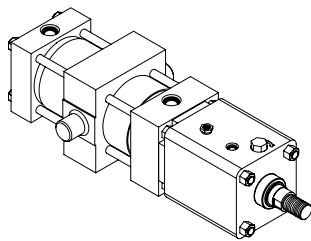

**DD Mount Single Rod End – Envelope and Mounting Dimensions**

Bore Ø	E	TD +0.000 -0.001	TL	TM	UM	UV	Style DD Minimum Stroke
1.50	2.00	1.000	1.00	2.50	4.50	2.50	3.25
2.00	2.50	1.000	1.00	3.00	5.00	3.00	4.00
2.50	3.00	1.000	1.00	3.50	5.50	3.50	3.88
3.25	3.75	1.000	1.00	4.50	6.50	4.25	4.38
4.00	4.50	1.000	1.00	5.25	7.25	5.00	4.88
5.00	5.50	1.000	1.00	6.25	8.25	6.00	5.13
6.00	6.50	1.375	1.38	7.63	10.38	7.00	6.13
8.00	8.50	1.375	1.38	9.75	12.50	9.50	11.75

**DD Mount Single Rod End – Rod Dimensions**

Bore Ø	Rod No.	MM Rod Ø	Thread		Rod Extensions and Pilot Dimensions							LG Add Stroke	XI* Minimum
			CC Style 8	KK Style 4 & 9	A	B +0.000 -0.002	C	D	NA	VD	WF		
1.50	1	0.625	1/2-20	7/16-20	0.75	1.124	0.38	0.50	0.56	0.38	1.00	6.50	9.00
	3	1.000	7/8-14	3/4-16	1.13	1.499	0.50	0.88	0.94	0.50	1.38	7.81	11.31
2.00	1	0.625	1/2-20	7/16-20	0.75	1.124	0.38	0.50	0.56	0.38	1.00	6.94	9.94
	3	1.000	7/8-14	3/4-16	1.13	1.499	0.50	0.88	0.94	0.50	1.38	8.06	11.44
2.50	1	0.625	1/2-20	7/16-20	0.75	1.124	0.38	0.50	0.56	0.50	1.00	9.13	12.50
	3	1.000	7/8-14	3/4-16	1.13	1.499	0.50	0.88	0.94	0.50	1.38	9.50	13.13
3.25	1	1.000	7/8-14	3/4-16	1.13	1.499	0.50	0.88	0.94	0.50	1.38	9.50	13.38
	3	1.375	1 1/4-12	1-14	1.63	1.999	0.63	1.13	1.31	0.63	1.63	9.75	13.88
4.00	1	1.000	7/8-14	3/4-16	1.13	1.499	0.50	0.88	0.94	0.50	1.38	10.13	14.50
	3	1.375	1 1/4-12	1-14	1.63	1.999	0.63	1.13	1.31	0.75	1.63	10.38	14.50
5.00	1	1.000	7/8-14	3/4-16	1.13	1.499	0.50	0.88	0.94	0.50	1.38	11.38	16.00
	3	1.375	1 1/4-12	1-14	1.63	1.999	0.63	1.13	1.31	0.75	1.63	11.88	16.75
6.00	1	1.000	7/8-14	3/4-16	1.13	1.499	0.50	0.88	0.94	0.50	1.38	12.38	17.50
	3	1.375	1 1/4-12	1-14	1.63	1.999	0.63	1.13	1.31	0.75	1.63	12.50	17.75
8.00	1	1.375	1 1/4-12	1-14	1.63	1.999	0.63	1.13	1.31	0.75	1.63	12.88	23.00
	3	1.750	1 1/2-12	1 1/4-12	2.00	2.374	0.75	1.50	1.69	0.88	1.88	12.88	23.75

\* Dimension XI to be specified by customer. If a shorter than minimum XI is required, the D Mount on page 18 may be suitable.

**Rod End Dimensions**

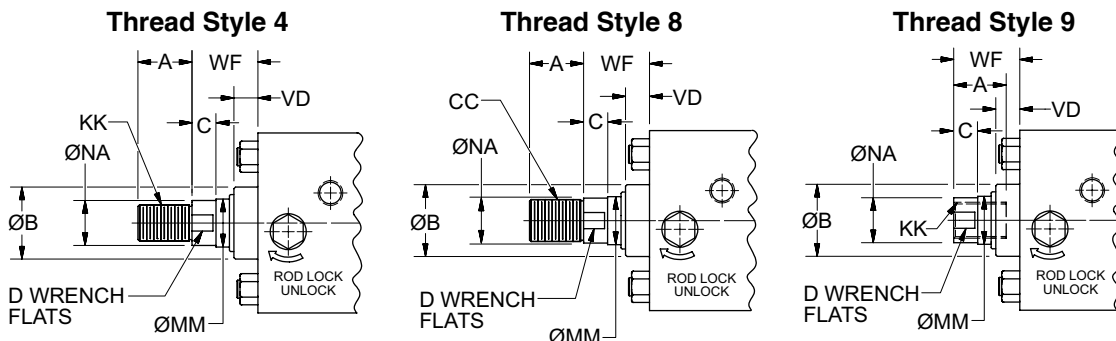

**“Special” Thread Style 3**  
 Special thread, extension, rod eye, blank, etc. are also available. To order, specify “Style 3” and give desired dimensions for KK, A, & WF. If otherwise special furnish dimensional sketch.

### How to Use Double Rod Cylinder Dimension Drawings

To determine dimensions for a double rod cylinder, first refer to the desired single rod mounting style cylinder shown on preceding pages of this catalog. After selecting necessary dimensions from that drawing, return to this page and supplement the single rod dimensions with those shown in the drawings and dimension table below. Note that double rod cylinders have a head (Dim. G) at both ends and that dimension LD replaces LG.

The double rod dimensions differ from, or are in addition to those for single rod cylinders shown on preceding pages and provide the information needed to completely dimension a double rod cylinder.

On a double rod cylinder, where the two rod ends are different, be sure to clearly state which rod end is to be assembled at which end. Port position #1 is standard. If other than standard, specify port position #2, 3 or 4 as viewed from one end only.

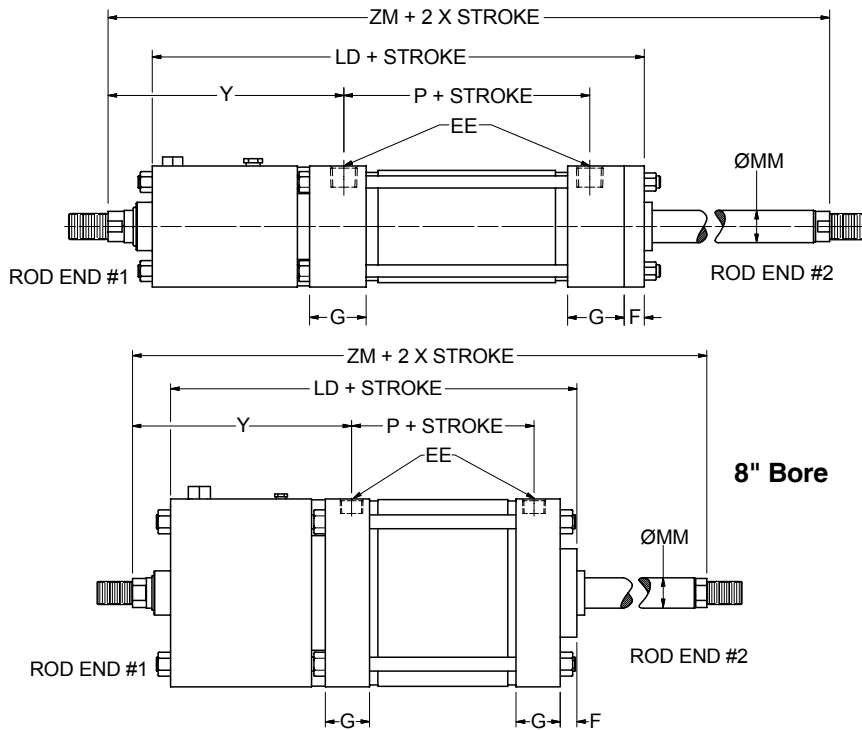

1 1/2" to 6" Bores

8" Bore

Mounting Styles for Single Rod Models	Corresponding Mounting Styles for Double Rod Models
T	KT
TB	KTB
TD	KTD
J	KJ
C	KC
F	KF
D	KD
DD	KDD

Bore Ø	Rod No.	MM Rod Ø	EE NPTF	F	G	P	Y	Add Stroke		Add 2X Stroke
								LD	SSK	ZM
1.50	1	0.625	3/8	0.38	1.50	2.25	4.81	7.00	2.88	9.00
	2	0.625	3/8	0.38	1.50	2.25	5.13	7.31	2.88	9.31
2.00	3	1.000	3/8	0.38	1.50	2.25	6.50	8.31	2.88	11.06
	4	1.000	3/8	0.38	1.50	2.38	5.13	7.44	3.00	9.44
2.50	1	0.625	3/8	0.38	1.50	2.38	6.63	8.56	3.00	11.31
	2	1.000	1/2	0.63	1.75	2.63	7.31	9.63	3.25	12.38
3.25	3	1.375	1/2	0.63	1.75	2.63	7.94	10.00	3.25	13.25
	4	1.000	1/2	0.63	1.75	2.63	7.69	10.00	3.25	12.75
4.00	3	1.375	1/2	0.63	1.75	2.63	8.19	10.25	3.25	13.50
	4	1.750	1/2	0.63	1.75	2.63	8.81	10.63	3.25	14.38
	5	1.000	1/2	0.63	1.75	2.88	8.31	10.88	3.13	13.63
5.00	3	1.375	1/2	0.63	1.75	2.88	8.94	11.25	3.13	14.50
	4	1.750	1/2	0.63	1.75	2.88	9.81	11.88	3.13	15.63
	5	1.375	3/4	0.75	2.00	3.13	9.69	12.38	3.63	15.63
6.00	3	1.750	3/4	0.75	2.00	3.13	10.44	12.88	3.63	16.63
	4	2.000	3/4	0.75	2.00	3.13	10.69	13.00	3.63	17.00
	5	1.375	3/4	0.75	2.00	3.25	10.06	13.63	3.75	16.13
8.00	3	1.750	3/4	0.75	2.00	3.25	10.81	14.13	3.75	17.13
	4	2.500	3/4	0.75	2.00	3.25	11.56	14.50	3.75	18.25
	Replaces Dimension									SS
On Single Rod Mounting Style									C	



**Parker Style “55” Flange Coupling  
Piston Rod End**

- Simplifies alignment
- Reduces assembly time
- Allows full rated pneumatic pressure in push and pull directions
- Available 5/8" through 2 1/2" piston rod diameters

**How to Order**

When preparing the Model Code enter a 55 in the Piston Rod Thread Style position.

Example: 2.50 J2AJLU155 X 8.00

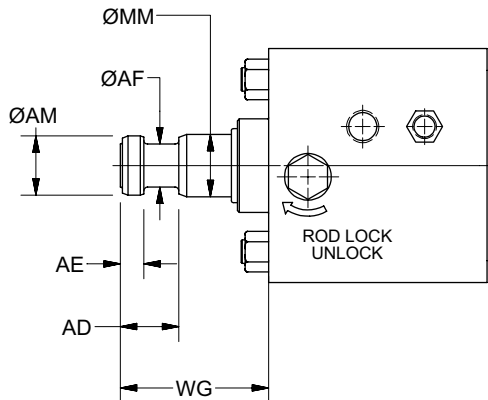

**Style 55 Rod End Dimensions**

MM Rod Ø	AD	AE	AF	AM	WG
0.625	0.63	0.25	0.38	0.57	1.75
1.000	0.94	0.38	0.69	0.95	2.38
1.375	1.06	0.38	0.88	1.32	2.75
1.750	1.31	0.50	1.13	1.70	3.13
2.000	1.69	0.63	1.38	1.95	3.75
2.500	1.94	0.75	1.75	2.45	4.50

**Split Couplers and Weld Plates**

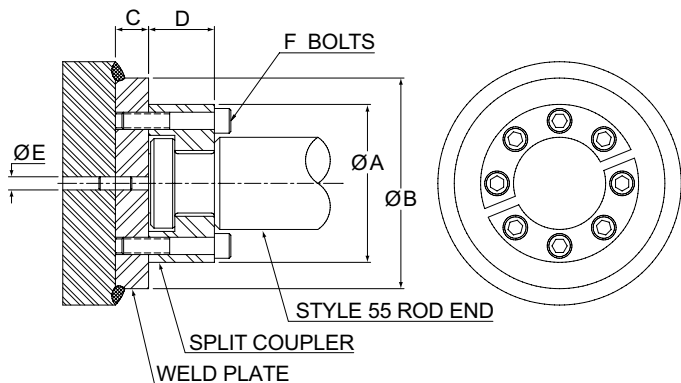

**⚠ WARNING:** Piston rod separation from the machine member can result in severe personal injury or even death to nearby personnel. The cylinder user must make sure the weld holding the weld plate to the machine is of sufficient quality and size to hold the intended load. The cylinder user must also make sure the bolts holding split coupler to the weld plate are of sufficient strength to hold the intended load and installed in such a way that they will not become loose during the machine's operation.

**Dimensions and Part Numbers**

MM Rod Ø	A	B	C	D	E	F	Bolt Size	Bolt Circle	Split Coupler Part Number	Weld Plate Part Number
0.625	1.50	2.00	0.50	0.56	0.25	4	#10-24 x 0.94 LG	1.13	1472340062	1481740062
1.000	2.00	2.50	0.50	0.88	0.25	6	1/4-20 x 1.25 LG	1.50	1472340100	1481740100
1.375	2.50	3.00	0.63	1.00	0.25	6	5/16-18 x 1.50 LG	2.00	1472340138	1481740138
1.750	3.00	4.00	0.63	1.25	0.25	8	5/16-18 x 1.75 LG	2.38	1472340175	1481740175
2.000	3.50	4.00	0.75	1.63	0.38	12	3/8-16 x 2.25 LG	2.69	1472340200	1481740200
2.500	4.00	4.50	0.75	1.88	0.38	12	3/8-16 x 2.50 LG	3.19	1472340250	1481740250



**Accessories for Mounting Style SB**

**Accessories for Mounting Style SB**

Accessories for mounting SB include Rod Eye, Pivot Pin and Clevis Bracket. To select the proper part number for any desired accessory refer to the charts below.

**Spherical Rod Eye**

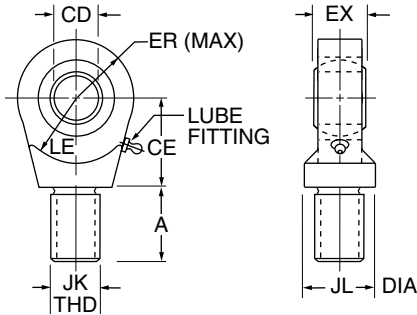

Bore Size	Series 2AJ	1 1/2, 2 & 2 1/2	3 1/4, 4 & 5	6 & 8
<b>Rod Eye</b>	<b>Part No.</b>	<b>1322900000</b>	<b>1322910000</b>	<b>1322920000</b>
	CD	.5000 -.0005	.7500 -.0005	1.0000 -.0005
	A	1 1/16	1	1 1/2
	CE	7/8	1 1/4	1 7/8
	EX	7/16	2 1/32	7/8
	ER	13/16	1 1/8	1 1/4
	LE	3/4	1 1/16	1 7/16
	JK	7/16-20	3/4-16	1-14
	JL	7/8	1 5/16	1 1/2
	<b>LOAD CAPACITY LBS.</b>	<b>2644</b>	<b>9441</b>	<b>16860</b>

Order to fit Piston Rod Thread Size.

**Pivot Pin**

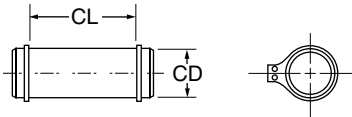

Bore Size	Series 2AJ	1 1/2, 2 & 2 1/2	3 1/4, 4 & 5	6 & 8
<b>Pivot Pin</b>	<b>Part No.</b>	<b>0839620000</b>	<b>0839630000</b>	<b>0839640000</b>
	CD	.4997 -.0004	.7497 -.0005	.9997 -.0005
	CL	1 9/16	2 1/32	2 1/2
	<b>LOAD CAPACITY LBS.</b>	<b>8600</b>	<b>19300</b>	<b>34300</b>

Pivot Pins are furnished with (2) Retainer Rings.

**Clevis Bracket**

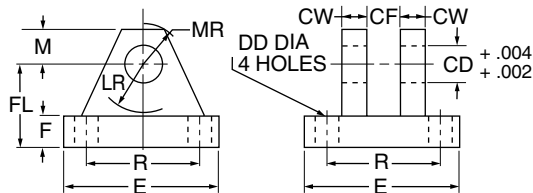

Bore Size	Series 2AJ	1 1/2, 2 & 2 1/2	3 1/4, 4 & 5	6 & 8
<b>Clevis Bracket</b>	<b>Part No.</b>	<b>0839470000</b>	<b>0839480000</b>	<b>0839490000</b>
	CD	1/2	3/4	1
	CF	7/16	2 1/32	7/8
	CW	1/2	5/8	3/4
	DD	13/32	17/32	17/32
	E	3	3 3/4	5 1/2
	F	1/2	5/8	3/4
	FL	1 1/2	2	2 1/2
	LR	15/16	1 3/8	1 11/16
	M	1/2	7/8	1
	MR	5/8	1	1 3/16
	R	2.05	2.76	4.10
	<b>LOAD CAPACITY LBS.</b>	<b>5770</b>	<b>9450</b>	<b>14300</b>

Order to fit Mounting Plate or Rod Eye.

**Cylinder Accessories**

Parker offers mounting accessories to provide you a complete cylinder mounting package. An Eye Bracket is available for Mounting Style BB. Select the Eye Bracket in the row to the right of the bore size cylinder required.

**Rod End Accessories**

Accessories offered for the rod end of the cylinder include Rod Clevis, Eye Bracket, Knuckle, Clevis Bracket and Pivot Pin. To select the proper part number for any desired accessory, refer to the table below or on the opposite page and look in the row to the right of the rod thread in the first column. For economical accessory selection, it is recommended that rod end style 4 be specified on your cylinder order.

**Accessory Load Capacity**

The various accessories have been load rated for your convenience. The load capacity in lbs. is the recommended maximum load for that accessory based on a 4:1 design factor in tension. (Pivot pin is rated in shear). Before specifying, compare the actual load or the tension (pull) force at maximum operating pressure of the cylinder with the load capacity of the accessory you plan to use. If the load or pull force of the cylinder exceeds the accessory capacity, consult the factory.

**Rod End Accessories**

Thread Size	Rod Clevis		Eye Bracket		Pivot Pin	
	Part Number	Load Capacity (Lbs.)	Part Number	Load Capacity (Lbs.)	Part Number	Load Capacity (Lbs.)
7/16-20	0509400000	4250	0691950000	4100	0683680000	8600
1/2-20	0509410000	4900	0691950000	4100	0683680000	8600
3/4-16	0509420000	11200	0691960000	10500	0683690000	19300
3/4-16	1332840000	11200	0691960000	10500	0683690000	19300
7/8-14	0509430000	18800	0853610000	20400	0683700000	34300
1-14	0509440000	19500	0853610000	20400	0683700000	34300
1-14	1332850000	19500	0853610000	20400	0683700000	34300
1 1/4-12	0509450000	33500	0691980000	21200	0683710000	65000
1 1/4-12	1332860000	33500	0691980000	21200	0683710000	65000
1 1/2-12	0509460000	45600	0853620000	49480	0683720000	105200
1 3/4-12	0509470000	65600	0853630000	70000	0683730000	137400
1 7/8-12	0509480000	65600	0853630000	70000	0683730000	137400
2 1/4-12	0509490000	98200	0853640000	94200	0683740000	214700

**Rod End Accessories**

Thread Size	Knuckle		Clevis Bracket		Pivot Pin	
	Part Number	Load Capacity (Lbs.)	Part Number	Load Capacity (Lbs.)	Part Number	Load Capacity (Lbs.)
7/16-20	0690890000	5000	0692050000	7300	0683680000	8600
1/2-20	0690900000	5700	0692050000	7300	0683680000	8600
3/4-16	0690910000	12100	0692060000	14000	0683690000	19300
7/8-14	0690920000	13000	0692070000	19200	0683700000	34300
1-14	0690930000	21700	0692070000	19200	0683700000	34300
1 1/4-12	0690940000	33500	0692080000	36900	0683710000	65000
1 1/2-12	0690950000	45000	0692090000	34000	0683720000	105200
1 3/4-12	0690960000	53500	0692100000	33000	0683730000	137400
1 7/8-12	0690970000	75000	0692100000	33000	0683730000	137400
2 1/4-12	0690980000	98700	0692110000	34900	0683740000	214700

**Cylinder Accessories**

Bore Ø	Eye Bracket	
	Part Number	Load Capacity (Lbs.)
1 1/2, 2, 2 1/2	0691950000	4100
3 1/4, 4, 5	0691960000	10500
6, 8	0853610000	20400



**Rod Clevis Dimensions**

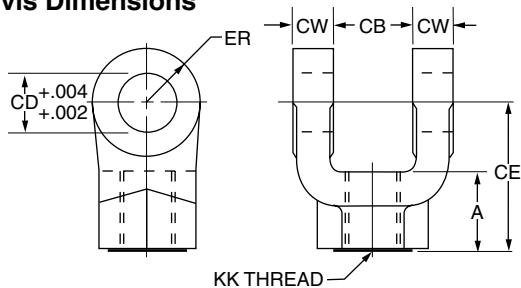

Part Number	A	CB	CD	CE	CW	ER	KK
0509400000	3/4	3/4	1/2	1 1/2	1/2	1/2	7/16-20
0509410000	3/4	3/4	1/2	1 1/2	1/2	1/2	1/2-20
0509420000	1 1/8	1 1/4	3/4	2 1/8	5/8	3/4	3/4-16
1332840000	1 1/8	1 1/4	3/4	2 3/8	5/8	3/4	3/4-16
0509430000	1 5/8	1 1/2	1	2 15/16	3/4	1	7/8-14
0509440000	1 5/8	1 1/2	1	2 15/16	3/4	1	1-14
1332850000	1 5/8	1 1/2	1	3 1/8	3/4	1	1-14
0509450000	1 7/8	2	1 3/8	3 3/4	1	1 3/8	1 1/4-12
1332860000	2	2	1 3/8	4 1/8	1	1 3/8	1 1/4-12
0509460000	2 1/4	2 1/2	1 3/4	4 1/2	1 1/4	1 3/4	1 1/2-12
0509470000	3	2 1/2	2	5 1/2	1 1/4	2	1 3/4-12
0509480000	3	2 1/2	2	5 1/2	1 1/4	2	1 7/8-12
0509490000	3 1/2	3	2 1/2	6 1/2	1 1/2	2 1/2	2 1/4-12

**Pivot Pin Dimensions**

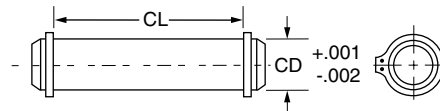

Part Number	CD	CL
0683680000	1/2	1 7/8
0683690000	3/4	2 5/8
0683700000	1	3 1/8
0683710000	1 3/8	4 1/8
0683720000	1 3/4	5 3/16
0683730000	2	5 3/16
0683740000	2 1/2	6 3/16

1. Pivot Pins are furnished with (2) retainer rings.
2. Pivot Pins must be ordered as a separate item if to be used with Rod Clevises or Clevis Brackets.

**Eye Bracket Dimensions**

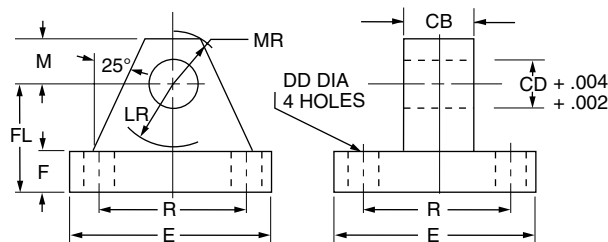

Part Number	CB	CD	DD	E	F	FL	LR	M	MR	R
0691950000	3/4	1/2	13/32	2 1/2	3/8	1 1/8	3/4	1/2	9/16	1.63
0691960000	1 1/4	3/4	17/32	3 1/2	5/8	1 7/8	1 1/4	3/4	7/8	2.55
0853610000	1 1/2	1	21/32	4 1/2	7/8	2 3/8	1 1/2	1	1 1/4	3.25
0691980000	2	1 3/8	21/32	5	7/8	3	2 1/8	1 3/8	1 5/8	3.82
0853620000	2 1/2	1 3/4	29/32	6 1/2	1 1/8	3 3/8	2 1/4	1 3/4	2 1/8	4.95
0853630000	2 1/2	2	1 1/16	7 1/2	1 1/2	4	2 1/2	2	2 7/16	5.73
0853640000	3	2 1/2	1 3/16	8 1/2	1 3/4	4 3/4	3	2 1/2	3	6.58

**Knuckle Dimensions**

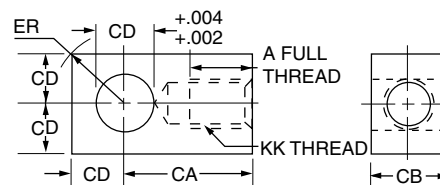

Part Number	A	CA	CB
0690890000	3/4	1 1/2	3/4
0690900000	3/4	1 1/2	3/4
0690910000	1 1/8	2 1/16	1 1/4
0690920000	1 1/8	2 3/8	1 1/2
0690930000	1 5/8	2 13/16	1 1/2
0690940000	2	3 7/16	2
0690950000	2 1/4	4	2 1/2
0690960000	2 1/4	4 3/8	2 1/2
0690970000	3	5	2 1/2
0690980000	3 1/2	5 13/16	3

Part Number	CD	ER	KK
0690890000	1/2	23/32	7/16-20
0690900000	1/2	23/32	1/2-20
0690910000	3/4	1 1/16	3/4-16
0690920000	1	1 7/16	7/8-14
0690930000	1	1 7/16	1-14
0690940000	1 3/8	1 31/32	1 1/4-12
0690950000	1 3/4	2 1/2	1 1/2-12
0690960000	2	2 27/32	1 3/4-12
0690970000	2	2 27/32	1 7/8-12
0690980000	2 1/2	3 9/16	2 1/4-12

**Clevis Bracket Dimensions**

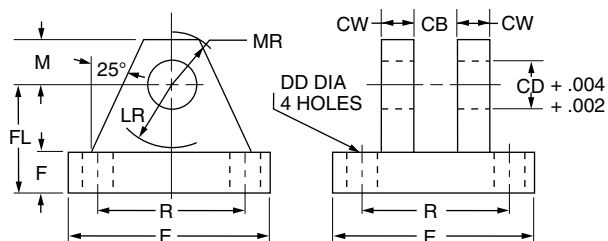

Part Number	CB	CD	CW	DD	E	F	FL	LR	M	MR	R
0692050000	3/4	1/2	1/2	13/32	3 1/2	1/2	1 1/2	3/4	1/2	5/8	2.55
0692060000	1 1/4	3/4	5/8	17/32	5	5/8	1 7/8	1 3/16	3/4	29/32	3.82
0692070000	1 1/2	1	3/4	21/32	6 1/2	3/4	2 1/4	1 1/2	1	1 1/4	4.95
0692080000	2	1 3/8	1	21/32	7 1/2	7/8	3	2	1 3/8	1 21/32	5.73
0692090000	2 1/2	1 3/4	1 1/4	29/32	9 1/2	7/8	3 5/8	2 3/4	1 3/4	2 7/32	7.50
0692100000	2 1/2	2	1 1/2	1 1/16	12 3/4	1	4 1/4	3 3/16	2 1/4	2 25/32	9.40
0692110000	3	2 1/2	1 1/2	1 3/16	12 3/4	1	4 1/2	3 1/2	2 1/2	3 1/8	9.40

**Rod Lock Removal**

To service the base 2AJ or 2ANJ cylinder the Rod Lock must first be removed.

**Note: The Rod Lock cannot be serviced nor is it considered a service item. The 2AJ or 2ANJ cylinder must be returned to the factory for Rod Lock service.**

1. Using a corner-to-corner sequence, remove the four hex tie rod nuts at the face of the Rod Lock.
2. Apply a minimum of 60 psi to the Rod Lock release port, or apply the appropriate torque to the manual override shaft to disengage the Rod Lock from the piston rod.
3. Carefully slide the Rod Lock off the cylinder. The Rod Lock is piloted and sealed to the gland OD which may necessitate carefully prying the unit from the gland retainer.
4. The 2AJ or 2ANJ cylinder can now be serviced per normal practice. See the following page for cylinder service kits.

**Rod Lock Installation**

1. Ensure that the mating surfaces of the Rod Lock and cylinder are free of dirt and debris.
2. Apply a minimum of 60 psi to the Rod Lock release port, or apply the appropriate torque to the manual override shaft to disengage the Rod Lock from the piston rod.
3. Carefully slide the rod lock onto the piston rod toward the base cylinder. Because the Rod Lock is sealed to the gland some force may be required to bring it in contact with the gland retainer. Take care not to damage the Rod Lock-to-gland o-ring seal.
4. Torque the hex tie rod nuts that secure the Rod Lock to the values in the table below. Be sure to reuse nuts supplied with the cylinder. Torque the nuts gradually, starting at one corner and work in a diagonal pattern to ensure evenness of tightening. **DO NOT TORQUE ONE NUT COMPLETELY AND THEN THE OTHERS.**
5. Remove air pressure from the Rod Lock release port or torque from the manual override release shaft to engage the Rod Lock.

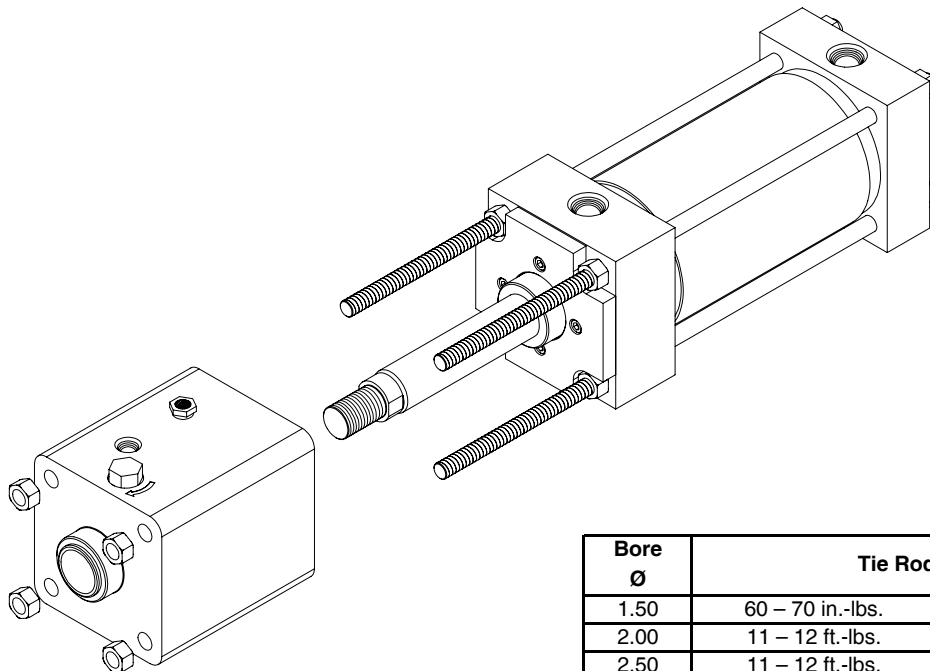

Bore Ø	Tie Rod Torque	
1.50	60 – 70 in.-lbs.	69 – 81 cm-kg
2.00	11 – 12 ft.-lbs.	15 – 16 N-m
2.50	11 – 12 ft.-lbs.	15 – 16 N-m
3.25	25 – 26 ft.-lbs.	34 – 35 N-m
4.00	25 – 26 ft.-lbs.	34 – 35 N-m
5.00	60 – 64 ft.-lbs.	81 – 87 N-m
6.00	60 – 64 ft.-lbs.	81 – 87 N-m
8.00	110 – 114 ft.-lbs.	149 – 155 N-m

1.50" through 8.00" Bore Sizes

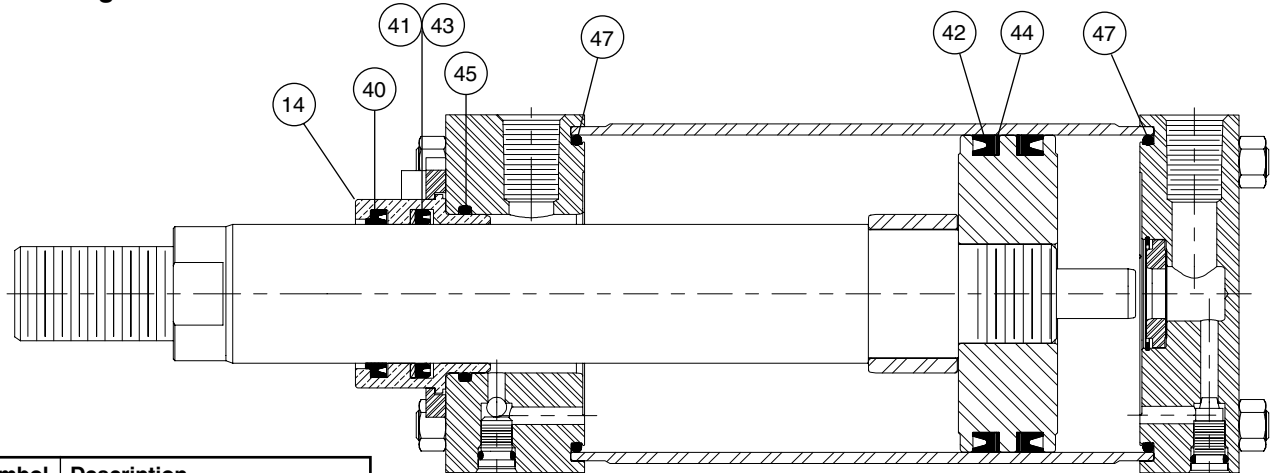

Symbol	Description
14	Rod Gland
40	Rod Wiper
41	Rod Seal
42	Piston Lipseal
43*	Rod Seal Back-up Washer
44*	Piston Seal Back-up Washer
45	Gland to Head O-ring
47	End Seal O-ring
121	Piston Wear Ring

\*Item not required in Series 2ANJ

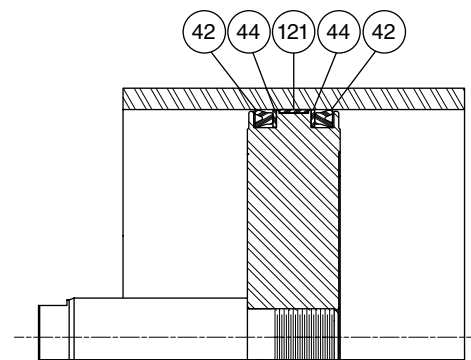

Lipseal Piston with Wear Ring  
8" Bore

Rod Gland & Rod Seal Kits

Rod Ø	Series 2AJ				Series 2ANJ	
	Class 1		Class 5		Class 1	
	Gland Cartridge Kits (Contains: 1 Each Sym. # 14, 40, 41, 43, & 45)	Rod Seal Kits (Contains: 1 Each Sym. # 40, 41, 43, & 45)	Gland Cartridge Kits (Contains: 1 Each Sym. # 14, 40, 41, 43, & 45)	Rod Seal Kits (Contains: 1 Each Sym. # 40, 41, 43, & 45)	Gland Cartridge Kits (Contains: 1 Each Sym. # 14, 40, 41, & 45)	Rod Seal Kits (Contains: 1 Each Sym. # 40, 41, & 45)
0.625	RG2AJ00061	RK2AJ00061	RG2AJ00065	RK2AJ00065	RG2ANJ0061	RK2ANJ0061
1.000	RG2AJ00101	RK2AJ00101	RG2AJ00105	RK2AJ00105	RG2ANJ0101	RK2ANJ0101
1.375	RG2AJ00131	RK2AJ00131	RG2AJ00135	RK2AJ00135	RG2ANJ0131	RK2ANJ0131
1.750	RG2AJ00171	RK2AJ00171	RG2AJ00175	RK2AJ00175	RG2ANJ0171	RK2AN00171
2.000	RG2AJ00201	RK2AJ00201	RG2AJ00205	RK2AJ00205	RG2ANJ0201	RK2ANJ0201
2.500	RG2AJ00251	RK2AJ00251	RG2AJ00255	RK2AJ00255	RG2ANJ0251	RK2ANJ0251

Piston Seal Kits

Bore Ø	Series 2AJ		Series 2ANJ
	Piston Seal Kits (Contains: 2 Each Sym. # 42, 44 & 47)		Piston Seal Kits (Contains: 2 Each Sym. # 42 & 47)
	Class 1	Class 5	Class 1
1.500	PK1502A001	PK1502A005	PK1502AN01
2.000	PK2002A001	PK2002A005	PK2002AN01
2.500	PK2502A001	PK2502A005	PK2502AN01
3.250	PK3202A001	PK3202A005	PK3202AN01
4.000	PK4002A001	PK4002A005	PK4002AN01
5.000	PK5002A001	PK5002A005	PK5002AN01
6.000	PK6002A001	PK6002A005	PK6002AN01
8.000	PK8002A001*	PK8002A005*	PK8002AN01*

Note: Class 5 seals do not increase temperature resistance of the cylinder and rod lock assembly

Specify Class 5 seals only for chemical compatibility.

\*Kit also includes one each item #121.



## Safety Guide for Selecting and Using Hydraulic, Pneumatic Cylinders and Their Accessories

**WARNING:** ⚠ **FAILURE OF THE CYLINDER, ITS PARTS, ITS MOUNTING, ITS CONNECTIONS TO OTHER OBJECTS, OR ITS CONTROLS CAN RESULT IN:**

- Unanticipated or uncontrolled movement of the cylinder or objects connected to it.
- Falling of the cylinder or objects held up by it.
- Fluid escaping from the cylinder, potentially at high velocity.

**THESE EVENTS COULD CAUSE DEATH OR PERSONAL INJURY BY, FOR EXAMPLE, PERSONS FALLING FROM HIGH LOCATIONS, BEING CRUSHED OR STRUCK BY HEAVY OR FAST MOVING OBJECTS, BEING PUSHED INTO DANGEROUS EQUIPMENT OR SITUATIONS, OR SLIPPING ON ESCAPED FLUID.**

Before selecting or using Parker Hannifin Corporation (the Company) cylinders or related accessories, it is important that you read, understand and follow the following safety information. Training is advised before selecting and using the Company's products.

### 1.0 General Instructions

**1.1 Scope** – This safety guide provides instructions for selecting and using (including assembling, installing, and maintaining) cylinder products. This safety guide is a supplement to and is to be used with the specific Company publications for the specific cylinder products that are being considered for use.

**1.2 Fail Safe** – Cylinder products can and do fail without warning for many reasons. All systems and equipment should be designed in a fail-safe mode so that if the failure of a cylinder product occurs people and property won't be endangered.

**1.3 Distribution** – Provide a free copy of this safety guide to each person responsible for selecting or using cylinder products. Do not select or use the Company's cylinders without thoroughly reading and understanding this safety guide as well as the specific Company publications for the products considered or selected.

**1.4 User Responsibility** – Due to very wide variety of cylinder applications and cylinder operating conditions, the Company does not warrant that any particular cylinder is suitable for any specific application. This safety guide does not analyze all technical parameters that must be considered in selecting a product. The hydraulic and pneumatic cylinders outlined in this catalog are designed to the Company's design guidelines and do not necessarily meet the design guideline of other agencies such as American Bureau of Shipping, ASME Pressure Vessel Code etc. The user, through its own analysis and testing, is solely responsible for:

- Making the final selection of the cylinders and related accessories.
- Determining if the cylinders are required to meet specific design requirements as required by the Agency(s) or industry standards covering the design of the user's equipment.
- Assuring that the user's requirements are met, OSHA requirements are met, and safety guidelines from the applicable agencies such as but not limited to ANSI are followed and that the use presents no health or safety hazards.
- Providing all appropriate health and safety warnings on the equipment on which the cylinders are used.

**1.5 Additional Questions** – Call the appropriate Company technical service department if you have any questions or require any additional information. See the Company publication for the product being considered or used, or call 1-847-298-2400, or go to [www.parker.com](http://www.parker.com), for telephone numbers of the appropriate technical service department.

### 2.0 Cylinder and Accessories Selection

**2.1 Seals** – Part of the process of selecting a cylinder is the selection of seal compounds. Before making this selection, consult the "seal information page(s)" of the publication for the series of cylinders of interest.

The application of cylinders may allow fluids such as cutting fluids, wash down fluids etc. to come in contact with the external area of the cylinder. These fluids may attack the piston rod wiper and or the primary seal and must be taken into account when selecting and specifying seal compounds.

Dynamic seals will wear. The rate of wear will depend on many operating factors. Wear can be rapid if a cylinder is mis-aligned or if the cylinder has been improperly serviced. The user must take seal wear into consideration in the application of cylinders.

**2.2 Piston Rods** – Possible consequences of piston rod failure or separation of the piston rod from the piston include, but are not limited to are:

- Piston rod and or attached load thrown off at high speed.
- High velocity fluid discharge.
- Piston rod extending when pressure is applied in the piston retract mode.

Piston rods or machine members attached to the piston rod may move suddenly and without warning as a consequence of other conditions occurring to the machine such as, but not limited to:

- Unexpected detachment of the machine member from the piston rod.

- Failure of the pressurized fluid delivery system (hoses, fittings, valves, pumps, compressors) which maintain cylinder position.
- Catastrophic cylinder seal failure leading to sudden loss of pressurized fluid.
- Failure of the machine control system.

Follow the recommendations of the "Piston Rod Selection Chart and Data" in the publication for the series of cylinders of interest. The suggested piston rod diameter in these charts must be followed in order to avoid piston rod buckling.

Piston rods are not normally designed to absorb bending moments or loads which are perpendicular to the axis of piston rod motion. These additional loads can cause the piston rod to fail. If these types of additional loads are expected to be imposed on the piston rod, their magnitude should be made known to our engineering department.

The cylinder user should always make sure that the piston rod is securely attached to the machine member.

On occasion cylinders are ordered with double rods (a piston rod extended from both ends of the cylinder). In some cases a stop is threaded on to one of the piston rods and used as an external stroke adjuster. On occasions spacers are attached to the machine member connected to the piston rod and also used as a stroke adjuster. In both cases the stops will create a pinch point and the user should consider appropriate use of guards. If these external stops are not perpendicular to the mating contact surface, or if debris is trapped between the contact surfaces, a bending moment will be placed on the piston rod, which can lead to piston rod failure. An external stop will also negate the effect of cushioning and will subject the piston rod to impact loading. Those two (2) conditions can cause piston rod failure. Internal stroke adjusters are available with and without cushions. The use of external stroke adjusters should be reviewed with our engineering department.

The piston rod to piston and the stud to piston rod threaded connections are secured with an anaerobic adhesive. The strength of the adhesive decreases with increasing temperature. Cylinders which can be exposed to temperatures above +250°F (+121°C) are to be ordered with a non studded piston rod and a pinned piston to rod joint.

**2.3 Cushions** – Cushions should be considered for cylinder applications when the piston velocity is expected to be over 4 inches/second.

Cylinder cushions are normally designed to absorb the energy of a linear applied load. A rotating mass has considerably more energy than the same mass moving in a linear mode. Cushioning for a rotating mass application should be reviewed by our engineering department.

**2.4 Cylinder Mountings** – Some cylinder mounting configurations may have certain limitations such as but not limited to minimum stroke for side or foot mounting cylinders or pressure de-ratings for certain mounts. Carefully review the catalog for these types of restrictions.

Always mount cylinders using the largest possible high tensile alloy steel socket head cap screws that can fit in the cylinder mounting holes and torque them to the manufacturer's recommendations for their size.

**2.5 Port Fittings** – Hydraulic cylinders applied with meter out or deceleration circuits are subject to intensified pressure at piston rod end.

The rod end pressure is approximately equal to:

$$\frac{\text{operating pressure} \times \text{effective cap end area}}{\text{effective rod end piston area}}$$

Contact your connector supplier for the pressure rating of individual connectors.

### 3.0 Cylinder and Accessories Installation and Mounting

#### 3.1 Installation

**3.1.1** – Cleanliness is an important consideration, and cylinders are shipped with the ports plugged to protect them from contaminants entering the ports. These plugs should not be removed until the piping is to be installed. Before making the connection to the cylinder ports, piping should be thoroughly cleaned to remove all chips or burrs which might have resulted from threading or flaring operations.

**3.1.2** – Cylinders operating in an environment where air drying materials are present such as fast-drying chemicals, paint, or weld splatter, or other hazardous conditions such as excessive heat, should have shields installed to prevent damage to the piston rod and piston rod seals.

**3.1.3** – Proper alignment of the cylinder piston rod and its mating component on the machine should be checked in both the extended and retracted positions. Improper alignment will result in excessive rod gland and/or cylinder bore wear. On fixed mounting cylinders attaching the piston rod while the rod is retracted will help in achieving proper alignment.

**3.1.4** – Sometimes it may be necessary to rotate the piston rod in order to thread the piston rod into the machine member. This operation must always be done with zero pressure being applied to either side of the piston. Failure to follow this procedure may result in loosening the piston to rod-threaded connection. In some rare cases the turning of the piston rod may rotate a threaded piston rod gland and loosen it from the cylinder head. Confirm that this condition is not occurring. If it does, re-tighten the piston rod gland firmly against the cylinder head.

For double rod cylinders it is also important that when attaching or detaching the piston rod from the machine member that the torque be applied to the piston rod end of the cylinder that is directly attaching to the machine member with the opposite end unrestrained. If the design of the machine is such that only the rod end of the cylinder opposite to where the rod attaches to the machine member can be rotated, consult the factory for further instructions.

### 3.2 Mounting Recommendations

**3.2.1** – Always mount cylinders using the largest possible high tensile alloy steel socket head screws that can fit in the cylinder mounting holes and torque them to the manufacturer's recommendations for their size.

**3.2.2** – Side-Mounted Cylinders – In addition to the mounting bolts, cylinders of this type should be equipped with thrust keys or dowel pins located so as to resist the major load.

**3.2.3** – Tie Rod Mounting – Cylinders with tie rod mountings are recommended for applications where mounting space is limited. The standard tie rod extension is shown as BB in dimension tables. Longer or shorter extensions can be supplied. Nuts used for this mounting style should be torqued to the same value as the tie rods for that bore size.

**3.2.4** – Flange Mount Cylinders – The controlled diameter of the rod gland extension on head end flange mount cylinders can be used as a pilot to locate the cylinders in relation to the machine. After alignment has been obtained, the flanges may be drilled for pins or dowels to prevent shifting.

**3.2.5** – Trunnion Mountings – Cylinders require lubricated bearing blocks with minimum bearing clearances. Bearing blocks should be carefully aligned and rigidly mounted so the trunnions will not be subjected to bending moments. The rod end should also be pivoted with the pivot pin in line and parallel to axis of the trunnion pins.

**3.2.6** – Clevis Mountings – Cylinders should be pivoted at both ends with centerline of pins parallel to each other. After cylinder is mounted, be sure to check to assure that the cylinder is free to swing through its working arc without interference from other machine parts.

### 4.0 Cylinder and Accessories Maintenance, Troubleshooting and Replacement

**4.1 Storage** – At times cylinders are delivered before a customer is ready to install them and must be stored for a period of time. When storage is required the following procedures are recommended.

**4.1.1** – Store the cylinders in an indoor area which has a dry, clean and noncorrosive atmosphere. Take care to protect the cylinder from both internal corrosion and external damage.

**4.1.2** – Whenever possible cylinders should be stored in a vertical position (piston rod up). This will minimize corrosion due to possible condensation which could occur inside the cylinder. This will also minimize seal damage.

**4.1.3** – Port protector plugs should be left in the cylinder until the time of installation.

**4.1.4** – If a cylinder is stored full of hydraulic fluid, expansion of the fluid due to temperature changes must be considered. Installing a check valve with free flow out of the cylinder is one method.

**4.1.5** – When cylinders are mounted on equipment that is stored outside for extended periods, exposed unpainted surfaces, e.g. piston rod, must be coated with a rust-inhibiting compound to prevent corrosion.

### 4.2 Cylinder Trouble Shooting

#### 4.2.1 – External Leakage

**4.2.1.1** – Rod seal leakage can generally be traced to worn or damaged seals. Examine the piston rod for dents, gouges or score marks, and replace piston rod if surface is rough.

Rod seal leakage could also be traced to gland wear. If clearance is excessive, replace rod bushing and seal. Rod seal leakage can also be traced to seal deterioration. If seals are soft or gummy or brittle, check compatibility of seal material with lubricant used if air cylinder, or operating fluid if hydraulic cylinder. Replace with seal material, which is compatible with these fluids. If the seals are hard or have lost elasticity, it is usually due to exposure to temperatures in excess of 165°F. (+74°C). Shield the cylinder from the heat source to limit temperature to 350°F. (+177°C.) and replace with fluorocarbon seals.

**4.2.1.2** – Cylinder body seal leak can generally be traced to loose tie rods. Torque the tie rods to manufacturer's recommendation for that bore size.

Excessive pressure can also result in cylinder body seal leak. Determine maximum pressure to rated limits. Replace seals and retorque tie rods as in paragraph above. Excessive pressure can also result in cylinder body seal leak. Determine if the pressure rating of the cylinder has been exceeded. If so, bring the operating pressure down to the rating of the cylinder and have the tie rods replaced.

Pinched or extruded cylinder body seal will also result in a leak. Replace cylinder body seal and retorque as in paragraph above.

Cylinder body seal leakage due to loss of radial squeeze which shows up in the form of flat spots or due to wear on the O.D. or I.D. – Either of these are symptoms of normal wear due to high cycle rate or length of service. Replace seals as per paragraph above.

#### 4.2.2 – Internal Leakage

**4.2.2.1** – Piston seal leak (by-pass) 1 to 3 cubic inches per minute leakage is considered normal for piston ring construction. Virtually no static leak with lipseal type seals on piston should be expected. Piston seal wear is a usual cause of piston seal leakage. Replace seals as required.

**4.2.2.2** – With lipseal type piston seals excessive back pressure due to over-adjustment of speed control valves could be a direct cause of rapid seal wear. Contamination in a hydraulic system can result in a scored cylinder bore, resulting in rapid seal wear. In either case, replace piston seals as required.

**4.2.2.3** – What appears to be piston seal leak, evidenced by the fact that the cylinder drifts, is not always traceable to the piston. To make sure, it is suggested that one side of the cylinder piston be pressurized and the fluid line at the opposite port be disconnected. Observe leakage. If none is evident, seek the cause of cylinder drift in other component parts in the circuit.

#### 4.2.3 – Cylinder Fails to Move the Load

**4.2.3.1** – Pneumatic or hydraulic pressure is too low. Check the pressure at the cylinder to make sure it is to circuit requirements.

**4.2.3.2** – Piston Seal Leak – Operate the valve to cycle the cylinder and observe fluid flow at valve exhaust ports at end of cylinder stroke. Replace piston seals if flow is excessive.

**4.2.3.3** – Cylinder is undersized for the load – Replace cylinder with one of a larger bore size.

#### 4.3 Erratic or Chatter Operation

**4.3.1** – Excessive friction at rod gland or piston bearing due to load misalignment – Correct cylinder-to-load alignment.

**4.3.2** – Cylinder sized too close to load requirements – Reduce load or install larger cylinder.

**4.3.3** – Erratic operation could be traced to the difference between static and kinetic friction. Install speed control valves to provide a back pressure to control the stroke.

**4.4 Cylinder Modifications, Repairs, or Failed Component** – Cylinders as shipped from the factory are not to be disassembled and or modified. If cylinders require modifications, these modifications must be done at company locations or by the Company's certified facilities. The Industrial Cylinder Division Engineering Department must be notified in the event of a mechanical fracture or permanent deformation of any cylinder component (excluding seals). This includes a broken piston rod, tie rod, mounting accessory or any other cylinder component. The notification should include all operation and application details. This information will be used to provide an engineered repair that will prevent recurrence of the failure.

It is allowed to disassemble cylinders for the purpose of replacing seals or seal assemblies. However, this work must be done by strictly following all the instructions provided with the seal kits.

## NOTES



## NOTES

## Offer of Sale

The items described in this document and other documents and descriptions provided by Parker Hannifin Corporation, its subsidiaries and its authorized distributors ("Seller") are hereby offered for sale at prices to be established by Seller. This offer and its acceptance by any customer ("Buyer") shall be governed by all of the following Terms and Conditions. Buyer's order for any item described in its document, when communicated to Seller verbally, or in writing, shall constitute acceptance of this offer. All goods, services or work described will be referred to as "Products".

**1. Terms and Conditions.** Seller's willingness to offer Products, or accept an order for Products, to or from Buyer is subject to these Terms and Conditions or any newer version of the terms and conditions found on-line at [www.parker.com/salesterms/](http://www.parker.com/salesterms/). Seller objects to any contrary or additional terms or conditions of Buyer's order or any other document issued by Buyer.

**2. Price Adjustments; Payments.** Prices stated on Seller's quote or other documentation offered by Seller are valid for 30 days, and do not include any sales, use, or other taxes unless specifically stated. Unless otherwise specified by Seller, all prices are F.C.A. Seller's facility (INCOTERMS 2010). Payment is subject to credit approval and is due 30 days from the date of invoice or such other term as required by Seller's Credit Department, after which Buyer shall pay interest on any unpaid invoices at the rate of 1.5% per month or the maximum allowable rate under applicable law.

**3. Delivery Dates; Title and Risk; Shipment.** All delivery dates are approximate and Seller shall not be responsible for any damages resulting from any delay. Regardless of the manner of shipment, title to any products and risk of loss or damage shall pass to Buyer upon placement of the products with the shipment carrier at Seller's facility. Unless otherwise stated, Seller may exercise its judgment in choosing the carrier and means of delivery. No deferral of shipment at Buyers' request beyond the respective dates indicated will be made except on terms that will indemnify, defend and hold Seller harmless against all loss and additional expense. Buyer shall be responsible for any additional shipping charges incurred by Seller due to Buyer's acts or omissions.

**4. Warranty.** Seller warrants that the Products sold hereunder shall be free from defects in material or workmanship for a period of eighteen months from the date of delivery to Buyer. The prices charged for Seller's products are based upon the exclusive limited warranty stated above, and upon the following disclaimer: **DISCLAIMER OF WARRANTY: THIS WARRANTY COMPRISES THE SOLE AND ENTIRE WARRANTY PERTAINING TO PRODUCTS PROVIDED HEREUNDER. SELLER DISCLAIMS ALL OTHER WARRANTIES, EXPRESS AND IMPLIED, INCLUDING DESIGN, MERCHANTABILITY AND FITNESS FOR A PARTICULAR PURPOSE.**

**5. Claims; Commencement of Actions.** Buyer shall promptly inspect all Products upon delivery. No claims for shortages will be allowed unless reported to the Seller within 10 days of delivery. No other claims against Seller will be allowed unless asserted in writing within 30 days after delivery. Buyer shall notify Seller of any alleged breach of warranty within 30 days after the date the defect is or should have been discovered by Buyer. Any action based upon breach of this agreement or upon any other claim arising out of this sale (other than an action by Seller for an amount due on any invoice) must be commenced within 12 months from the date of the breach without regard to the date breach is discovered.

**6. LIMITATION OF LIABILITY.** UPON NOTIFICATION, SELLER WILL, AT ITS OPTION, REPAIR OR REPLACE A DEFECTIVE PRODUCT, OR REFUND THE PURCHASE PRICE. IN NO EVENT SHALL SELLER BE LIABLE TO BUYER FOR ANY SPECIAL, INDIRECT, INCIDENTAL OR CONSEQUENTIAL DAMAGES ARISING OUT OF, OR AS THE RESULT OF, THE SALE, DELIVERY, NON-DELIVERY, SERVICING, USE OR LOSS OF USE OF THE PRODUCTS OR ANY PART THEREOF, OR FOR ANY CHARGES OR EXPENSES OF ANY NATURE INCURRED WITHOUT SELLER'S WRITTEN CONSENT, EVEN IF SELLER HAS BEEN NEGLIGENT, WHETHER IN CONTRACT, TORT OR OTHER LEGAL THEORY. IN NO EVENT SHALL SELLER'S LIABILITY UNDER ANY CLAIM MADE BY BUYER EXCEED THE PURCHASE PRICE OF THE PRODUCTS.

**7. User Responsibility.** The user, through its own analysis and testing, is solely responsible for making the final selection of the system and Product and assuring that all performance, endurance, maintenance, safety and warning requirements of the application are met. The user must analyze all aspects of the application and follow applicable industry standards and Product information. If Seller provides Product or system options, the user is responsible for determining that such data and specifications are suitable and sufficient for all applications and reasonably foreseeable uses of the Products or systems.

**8. Loss to Buyer's Property.** Any designs, tools, patterns, materials, drawings, confidential information or equipment furnished by Buyer or any other items which become Buyer's property, will be considered obsolete and may be destroyed by Seller after two consecutive years have elapsed without Buyer ordering the items manufactured using such property. Seller shall not be responsible for any loss or damage to such property while it is in Seller's possession or control.

**9. Special Tooling.** A tooling charge may be imposed for any special tooling, including without limitation, dies, fixtures, molds and patterns, acquired to manufacture Products. Such special tooling shall be and remain Seller's property notwithstanding payment of any charges by Buyer. In no event will Buyer acquire any interest in apparatus belonging to Seller which is utilized in the manufacture of the Products, even if such apparatus has been specially converted or adapted for such manufacture and notwithstanding any charges paid by Buyer. Unless otherwise agreed, Seller shall have the right to alter, discard or otherwise dispose of any special tooling or other property in its sole discretion at any time.

**10. Buyer's Obligation; Rights of Seller.** To secure payment of all sums due or otherwise, Seller shall retain a security interest in the goods delivered and this agreement shall be deemed a Security Agreement under the Uniform Commercial Code. Buyer authorizes Seller as its attorney to execute and file on Buyer's behalf all documents Seller deems necessary to perfect its security interest.

**11. Improper use and Indemnity.** Buyer shall indemnify, defend, and hold Seller harmless from any claim, liability, damages, lawsuits, and costs (including attorney fees), whether for personal injury, property damage, patent, trademark or copyright

infringement or any other claim, brought by or incurred by Buyer, Buyer's employees, or any other person, arising out of: (a) improper selection, improper application or other misuse of Products purchased by Buyer from Seller; (b) any act or omission, negligent or otherwise, of Buyer; (c) Seller's use of patterns, plans, drawings, or specifications furnished by Buyer to manufacture Product; or (d) Buyer's failure to comply with these terms and conditions. Seller shall not indemnify Buyer under any circumstance except as otherwise provided.

**12. Cancellations and Changes.** Orders shall not be subject to cancellation or change by Buyer for any reason, except with Seller's written consent and upon terms that will indemnify, defend and hold Seller harmless against all direct, incidental and consequential loss or damage. Seller may change product features, specifications, designs and availability with notice to Buyer.

**13. Limitation on Assignment.** Buyer may not assign its rights or obligations under this agreement without the prior written consent of Seller.

**14. Force Majeure.** Seller does not assume the risk and shall not be liable for delay or failure to perform any of Seller's obligations by reason of circumstances beyond the reasonable control of Seller (hereinafter "Events of Force Majeure"). Events of Force Majeure shall include without limitation: accidents, strikes or labor disputes, acts of any government or government agency, acts of nature, delays or failures in delivery from carriers or suppliers, shortages of materials, or any other cause beyond Seller's reasonable control.

**15. Waiver and Severability.** Failure to enforce any provision of this agreement will not waive that provision nor will any such failure prejudice Seller's right to enforce that provision in the future. Invalidation of any provision of this agreement by legislation or other rule of law shall not invalidate any other provision herein. The remaining provisions of this agreement will remain in full force and effect.

**16. Termination.** Seller may terminate this agreement for any reason and at any time by giving Buyer thirty (30) days written notice of termination. Seller may immediately terminate this agreement, in writing, if Buyer: (a) commits a breach of any provision of this agreement (b) appoints a trustee, receiver or custodian for all or any part of Buyer's property (c) files a petition for relief in bankruptcy on its own behalf, or by a third party (d) makes an assignment for the benefit of creditors, or (e) dissolves or liquidates all or a majority of its assets.

**17. Governing Law.** This agreement and the sale and delivery of all Products hereunder shall be deemed to have taken place in and shall be governed and construed in accordance with the laws of the State of Ohio, as applicable to contracts executed and wholly performed therein and without regard to conflicts of laws principles. Buyer irrevocably agrees and consents to the exclusive jurisdiction and venue of the courts of Cuyahoga County, Ohio with respect to any dispute, controversy or claim arising out of or relating to this agreement.

**18. Indemnity for Infringement of Intellectual Property Rights.** Seller shall have no liability for infringement of any patents, trademarks, copyrights, trade dress, trade secrets or similar rights except as provided in this Section. Seller will defend and indemnify Buyer against allegations of infringement of U.S. patents, U.S. trademarks, copyrights, trade dress and trade secrets ("Intellectual Property Rights"). Seller will defend at its expense and will pay the cost of any settlement or damages awarded in an action brought against Buyer based on an allegation that a Product sold pursuant to this Agreement infringes the Intellectual Property Rights of a third party. Seller's obligation to defend and indemnify Buyer is contingent on Buyer notifying Seller within ten (10) days after Buyer becomes aware of such allegations of infringement, and Seller having sole control over the defense of any allegations or actions including all negotiations for settlement or compromise. If a Product is subject to a claim that it infringes the Intellectual Property Rights of a third party, Seller may, at its sole expense and option, procure for Buyer the right to continue using the Product, replace or modify the Product so as to make it noninfringing, or offer to accept return of the Product and return the purchase price less a reasonable allowance for depreciation. Notwithstanding the foregoing, Seller shall have no liability for claims of infringement based on information provided by Buyer, or directed to Products delivered hereunder for which the designs are specified in whole or part by Buyer, or infringements resulting from the modification, combination or use in a system of any Product sold hereunder. The foregoing provisions of this Section shall constitute Seller's sole and exclusive liability and Buyer's sole and exclusive remedy for infringement of Intellectual Property Rights.

**19. Entire Agreement.** This agreement contains the entire agreement between the Buyer and Seller and constitutes the final, complete and exclusive expression of the terms of sale. All prior or contemporaneous written or oral agreements or negotiations with respect to the subject matter are herein merged.

**20. Compliance with Law, U. K. Bribery Act and U.S. Foreign Corrupt Practices Act.** Buyer agrees to comply with all applicable laws and regulations, including both those of the United Kingdom and the United States of America, and of the country or countries of the Territory in which Buyer may operate, including without limitation the U. K. Bribery Act, the U.S. Foreign Corrupt Practices Act ("FCPA") and the U.S. Anti-Kickback Act (the "Anti-Kickback Act"), and agrees to indemnify and hold harmless Seller from the consequences of any violation of such provisions by Buyer, its employees or agents. Buyer acknowledges that they are familiar with the provisions of the U. K. Bribery Act, the FCPA and the Anti-Kickback Act, and certifies that Buyer will adhere to the requirements thereof. In particular, Buyer represents and agrees that Buyer shall not make any payment or give anything of value, directly or indirectly to any governmental official, any foreign political party or official thereof, any candidate for foreign political office, or any commercial entity or person, for the purpose of influencing such person to purchase products or otherwise benefit the business of Seller.





**Parker Hannifin Corporation**  
500 South Wolf Road  
Des Plaines, IL 60016 USA  
Tel: (847) 298-2400  
Fax: (800) 892-1008  
E Mail: [Cylmktg@parker.com](mailto:Cylmktg@parker.com)  
Website: [www.parker.com/cylinder](http://www.parker.com/cylinder)

**Parker Hannifin Corporation**  
160 Chisholm Drive  
Milton, Ontario  
Canada L9T 3G9  
Tel: (905) 693-3000  
Fax: (905) 876-1958

Catalog HY08-0931-1/NA  
07/14

© Copyright 2014,  
Parker Hannifin Corporation  
All rights reserved.