

WST Stopper Cylinder



Specifications

Features		
Media	Clean dry compressed air	
Operating Pressure Range	22 to 102 psi (1.5 to 7 Bar)	
Max* Pressure	145 psi (10 Bar)	
Operating Temperature Range	32 to 140°F (0 to 60°C)	
Operating Speed Range mm/s	50-500	
Cushion	Urethane Bumper	
Connecting Port	G1/8" (BSP)	
Lubrication	Sealed, lubricated for life	
Shock Absorber	WSAB2012-R	WSAB3625-C
Mounting Type	Flange	Plate
Stroke Tolerance	0-1.5mm	
Bore Size and Stroke Length		
Model	Bore Size	Stroke
WSTV(S)	50, 80	30
WSTSV(S)	50, 80	30
WSTH(S)	50	50

*The units are not designed to operate at this pressure. Exceeding the operating pressure range may cause damage to reduce the life of the unit.

Series WST Ø50mm & 80mm

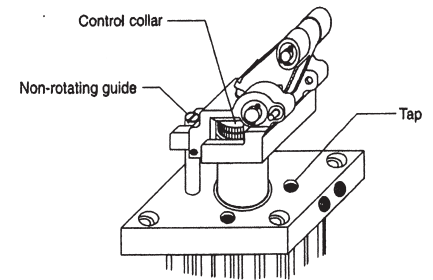

How to adjust the shock absorber

The shock absorber is set to maximum damping upon delivery. When in operation, adjust the damping of the shock absorber by adjusting the control collar. For the vertical model, it's shown above. For the horizontal model, by the graduated collar.

Gradually reduce the damping level until the load comes to rest in the correct position, without any shock deceleration of the load.

If the load forces the damper to its fully retracted position too rapidly (normally apparent due to a sudden deceleration at the end of stroke), then this may lead to mechanical damage of the unit. In this case, increase the damping to remove the shock deceleration.

Periodically regulate the damping of each unit to maintain the shock absorber energy higher than the apparent load energy.

Shock absorber replacement

If correctly set, the shock absorber will operate trouble free.

Vertical type

Unfasten the head using a spanner while holding the cylinder rod in place.

Replace the shock absorber on the piston rod.

Refasten the head and readjust the shock absorber.

Horizontal type

Loosen and remove the locking collar. Remove the shock absorber and replace it.

Precautions

1. Please note that if the impact energy exceeds the shock absorber energy that is currently set then the cylinder and frame will absorb the excess energy.
2. Keep all moving parts free from scratches or defects, as they may lead to defective operation.
3. The unit must be securely fastened to a fixed surface, to prevent free rotation. Any rotation may lead to incorrect operation or damage.
4. Please keep clear of all moving parts during operation.
5. The sensors are secured by a thread fixing with the mounting slots along the side of the cylinder.
To reposition a sensor:
Loosen the threaded fastener.
Slide the sensor along the groove to its new position.
Tighten the threaded fastener locking the sensor in place.

WST Stopper Cylinder



Ordering Information

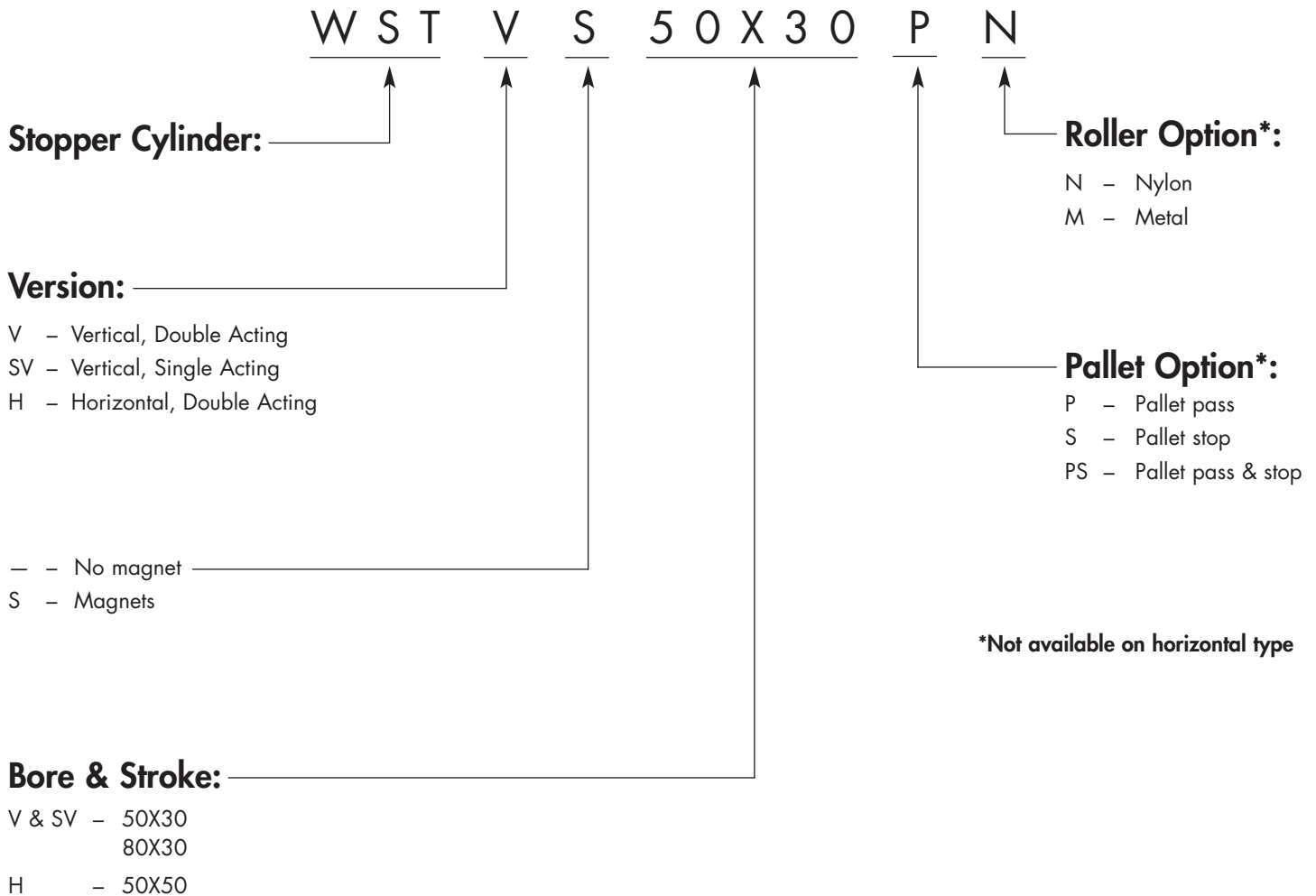

Proximity Sensors

Order #	Description
WE102A/B	Reed Type, 2 wire cable, DC10-28V, AC85-115V
WE155A/B	Reed Type, 3 wire cable, LED, DC4.5V-28V
WS3HA/B	Reed Type, 2 wire cable, LED, DC10-30V (10-50mA), AC85-115V (10-50nA)
WS4HA/B	Reed Type, 2 wire cable, LED, DC10-30V (5-25mA), AC85-115V (5-20nA)
WS9HA/B	Reed Type, 3 wire cable, LED, DC4.5-28V (10-50mA)

WST Stopper Cylinder



Cylinder Sizing

Type – WSTV(S), WSTSV(S)

Pressure vs Load

Graph 1

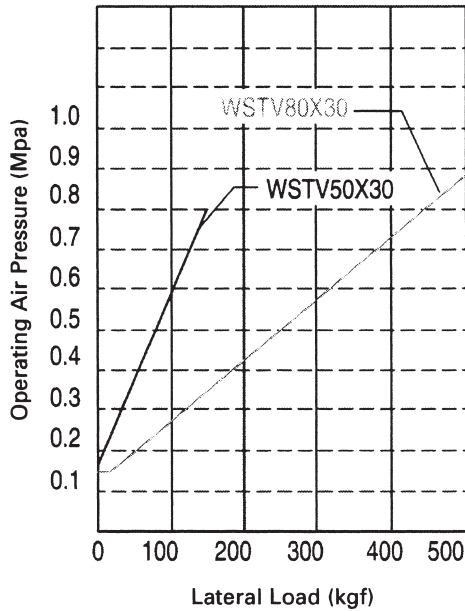

Load vs Speed

Graph 2

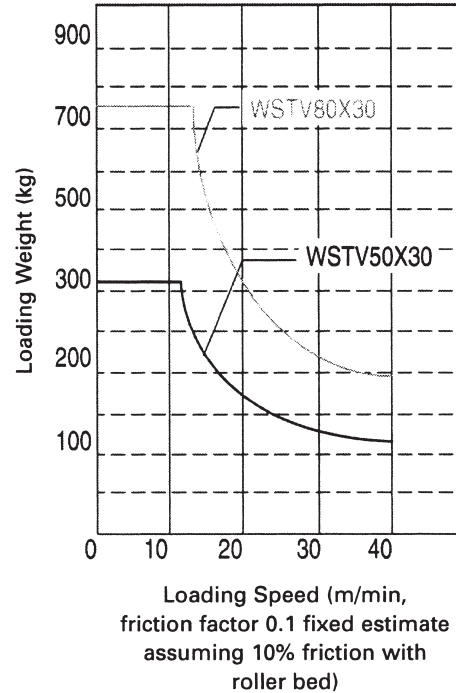

Example for selection of stopper cylinder

Check the requirements:

1. Loading speed
2. Loading weight
3. Operating pressure



Bore size selection:

1. Select the cylinder size from Graph 2 using the loading speed and weight
2. Check the estimated operating pressure from Graph 1

For example: A load of 200kg travelling at 15m/min with an estimated friction factor of 0.1.
Cross referencing 200kg and 15m/min on Graph 2 gives a WSTV 50x30.
Checking on Graph 1 with a lateral load of $0.1 \times 200\text{kg} = 20\text{kg}$ on a WSTV 50x30.
This is below the graph line showing it to be acceptable for the application.

WST Stopper Cylinder



Cylinder Sizing

Type – WSTH(S)

Pressure vs Load

Graph 1

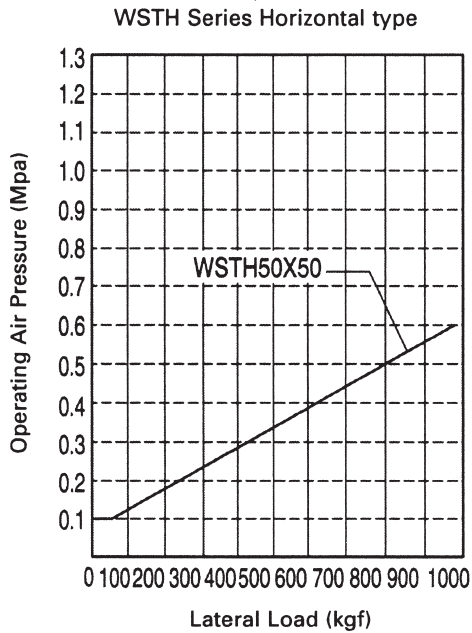

Load vs Speed

Graph 2

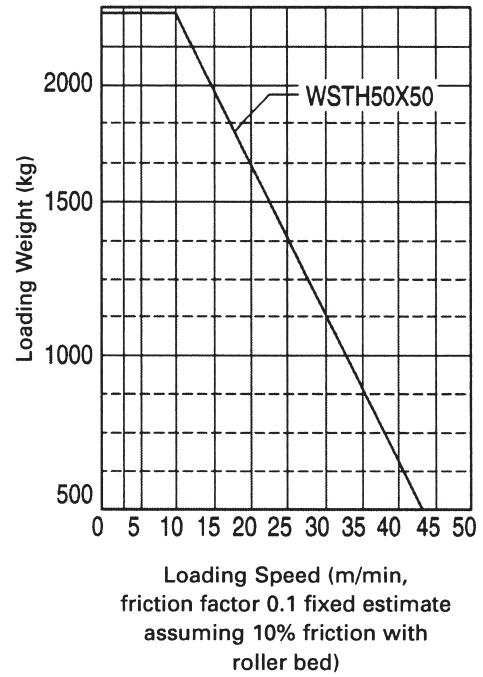

Example

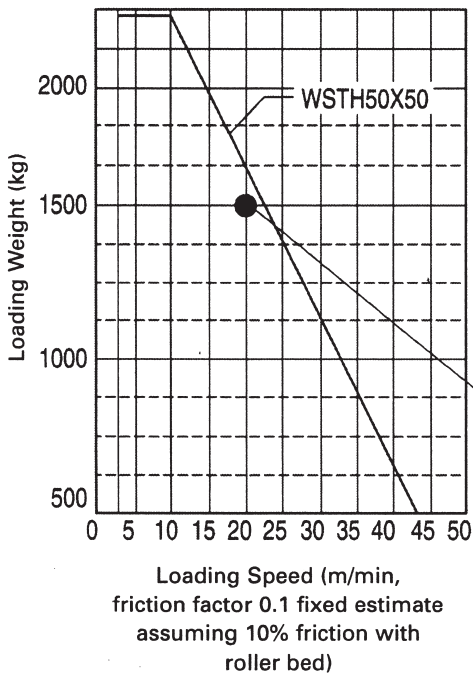

1. Specify load weight
2. Specify load speed
3. Check that it falls within the graph line

For example:
Mass of 1500kg with a speed of 20m/min is below the line making it acceptable for a WSTH 50x50

AZ Cylinder



Specifications

Features	
Type	ISO 6431 VDMA 24562 CETOP RP43P
Series	AZ
Configurations	AZ Double Acting, Single Rod, Magnetic Piston, Cushions AZD Double Acting, Double Rod, Magnetic Piston
Construction Materials	
Barrel	Extruded Aluminum, Anodized (10µ)
End Caps	Die Cast Aluminum
Piston Rod	Stainless Steel
Rod Bearing	Teflon Impregnated Bronze
Piston	Molded NBR, (Optional: Viton)
Cushions Needle	Brass
Seals	Urethane, (Optional: Viton)
End Cap Screws	Steel, zinc plated
Characteristics	
Operating Temperature	Min: -5° F (-20°C) Max: +176 °F (+80°C)
Operating Pressure	Min: 15 PSI (1 bar) Max: 145 PSI (10 bar)
Normal Operating Pressure	90 PSI (6 bar)
Lubrication	Pre-lubricated at factory. If additional lubrication is required use oil compatible for NBR seal and designed for use in pneumatic systems.
Media	Filtered and regulated compressed air
Installation	In any position
Weight	See chart with mounts
Stroke Length	Up to 500mm - Longer contact factory
Theoretical Forces	See Technical Information Sheet
Load Capacity	See Technical Information Sheet
Specifications	
Piston Diameter	32 40 50 63 80 100
Port Sizes	Metric (G) G1/8 G1/4 G1/4 G3/8 G3/8 G1/2
Rod Diameter	mm 12 16 20 20 25 25
Cushion Lengths All Cylinders	mm 21 25 28 30 30 37

Series AZ

Ø32mm - 100mm

ISO 6431
VDMA 24562
CETOP RP43P

**AZ 5: Double Acting, Single Rod,
Magnets, Cushions**

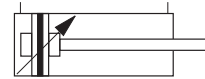

**AZD 6: Double Acting, Double Rod,
Magnets**

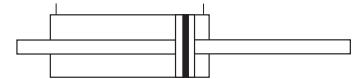

Features:

**Stainless Steel Rod
Magnetic Piston
Adjustable Cushions
Pre-Lubricated Design
Captive Cushion Needles**

AZ Cylinder



Ordering Information

Example: AZ 5050/25-V
 ISO 6431
 Single Rod
 Double Acting, Magnets, Cushions
 50mm Bore
 25mm Stroke
 Viton Seals

AZ 5050 / 25 - V

Versions:

AZ - Single Rod
 AZD - Double Rod

Actuation:

Standard

5 - Double Acting, Magnets, Cushions
 1 - Double Acting, Cushions
 6 - Double Acting, Magnets
 2 - Double Acting

Options:

- - Standard
 V - Viton
 D2L - Front, Single End Porting
 B2L - Rear, Single End Porting

Stroke:

MM: (standard)
 • any mm increment up to 500mm standard
 • contact factory for special stroke lengths

Bore:

032 - 32 mm (nom. 1-1/4")
 040 - 40 mm (nom. 1-1/2")
 050 - 50 mm (nom. 2")
 063 - 63 mm (nom. 2-1/2")
 080 - 80 mm (nom. 3-1/8")
 100 - 100 mm (nom. 4")
 Contact factory for bore sizes: 125, 160, 200, 250, and 320mm.

Proximity Sensors/Brackets: See Page 73

Description	Bore Ø					
	32mm	40mm	50mm	63mm	80mm	100mm
Foot bracket, Type A	PD 27917	PD 27918	PD 28072	PD 28073	PD 28074	PD 28075
Rear double clevis, Type B	PD 22704	PD 22705	PD 22706	PD 22707	PD 22708	PD 22709
Rear single clevis, Type BA	PD 23412	PD 23413	PD 23414	PD 23415	PD 23416	PD 23417
Rear single clevis w/bearing, Type BAS	PD 23843	PD 23844	PD 23845	PD 23846	PD 23847	PD 23848
Front flange, Type C	PD 23403	PD 23404	PD 23405	PD 23406	PD 23407	PD 23408
Rear flange, Type D	PD 23403	PD 23404	PD 23405	PD 23406	PD 23407	PD 23408
Center trunnion, Type EN	PD 39195	PD 39196	PD 39197	PD 39198	PD 39199	PD 39200
Clevis Pin for mounting types B, BA, BAS	KY 6153	KY 6154	KY 6157	KY 6156	KY 6158	KY 6159

Delivery information: all cylinder mountings, except the trunnion mounting, are shipped unassembled

AZ Cylinder



Dimensional Data

AZ Ø32-100mm

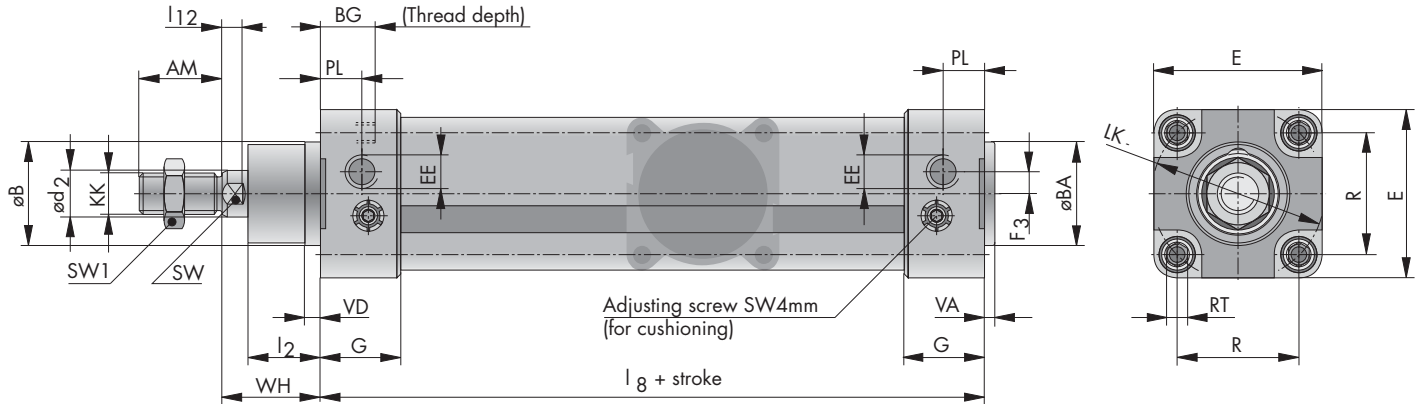

AZD Ø32-100mm

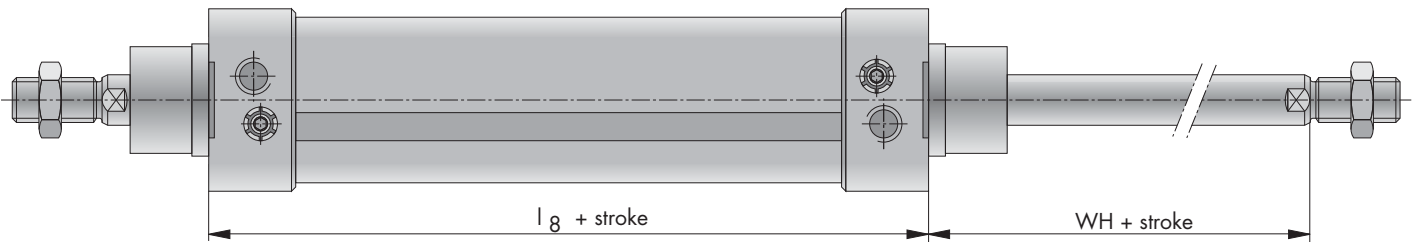

Bore ø	AM	øB	øBA	BG	ød	E	EE	F ₃	G	KK	l ₂	l _g +stroke	l ₁₂	øLK	PL	R	RT	SW	SW ₁	VA	VD	WH+*stroke
32	0.79	1.18	1.18	0.63	0.47	1.85	1/8 NPT	0.18	1.20	3/8-24	0.79	3.70	0.24	1.81	0.39	1.28	1/4-20	0.39	0.67	0.16	0.20	1.02
	20	30	30	16	12	47	G1/8	4.5	30.5	M10 X 1.25	20	94	6	46	9.8	32.5	M6	10	17	4	5	26
40	0.94	1.38	1.38	0.63	0.63	2.17	1/4 NPT	0.21	1.34	7/16-20	0.81	4.13	0.26	2.13	0.57	1.50	1/4-20	0.51	0.75	0.16	0.30	1.18
	24	35	35	16	16	55	G1/4	5.3	34	M12 X 1.25	20.5	105	6.5	54	14.5	38	M6	13	19	4	5	30
50	1.26	1.57	1.57	0.63	0.79	2.56	1/4 NPT	0.33	1.22	5/8-18	1.10	4.17	0.31	2.60	0.63	1.83	5/16-18	0.67	0.94	0.16	0.24	1.46
	32	40	40	16	20	65	G1/4	8.5	31	M16 X 1.50	28	106	8	66	16	46.5	M8	17	24	4	6	37
63	1.26	1.77	1.77	0.63	0.79	3.07	3/8 NPT	0.31	1.30	5/8-18	1.02	4.76	0.31	3.15	0.63	2.22	5/16-18	0.67	0.94	0.16	0.24	1.46
	32	45	45	16	20	78	G3/8	8	33	M16 X 1.50	26	121	8	80	16	56.5	M8	17	24	4	6	37
80	1.57	1.77	1.77	0.63	0.98	3.74	3/8 NPT	0.35	1.40	3/4-16	1.28	5.04	0.39	4.02	0.81	2.83	3/8-16	0.87	1.18	0.16	0.24	1.81
	40	45	45	16	25	95	G3/8	9	35.5	M20 X 1.50	32.5	128	10	102	20.5	72	M10	22	30	4	6	46
100	1.57	2.17	2.17	0.63	0.98	4.53	1/2 NPT	0.51	1.46	3/4-16	1.48	5.43	0.39	4.96	0.75	3.50	3/8-16	0.87	1.18	0.16	0.24	2.01
	40	55	55	16	25	115	G1/2	13	37	M20 X 1.50	37.5	138	10	126	19	89	M10	22	30	4	6	51

AZ Cylinder



Cylinder Mounts

Foot Bracket- Type A

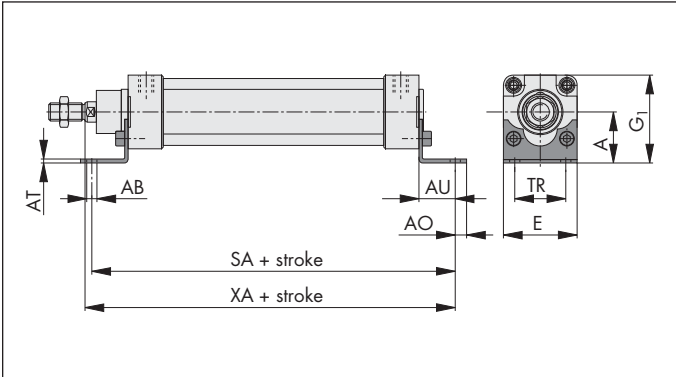

Bore ø	AB	AH	AO	AT	AU	E	G ₁	TR	SA+ stroke	XA+ stroke
32	0.28	1.26	0.31	0.12	0.94	1.85	2.19	1.26	5.59	5.67
	7	32	8	3	24	47	55.5	32	142	144
40	0.35	1.42	0.39	0.12	1.10	2.09	2.46	1.42	6.34	6.42
	9	36	10	3	28	53	62.5	36	161	163
50	0.35	1.77	0.39	0.12	1.26	2.56	3.05	1.77	6.69	6.89
	9	45	10	3	32	65	77.5	45	170	175
63	0.35	1.97	0.39	0.12	1.26	2.95	3.44	1.97	7.28	7.48
	9	50	10	3	32	75	87.5	50	185	190
80	0.47	2.48	0.55	0.16	1.61	3.74	4.35	2.48	8.27	8.46
	12	63	14	4	41	95	110.5	63	210	215
100	0.55	2.80	0.59	0.16	1.61	4.53	5.06	2.95	8.66	9.06
	14	71	15	4	41	115	128.5	75	220	23

Rear Double Clevis- Type B

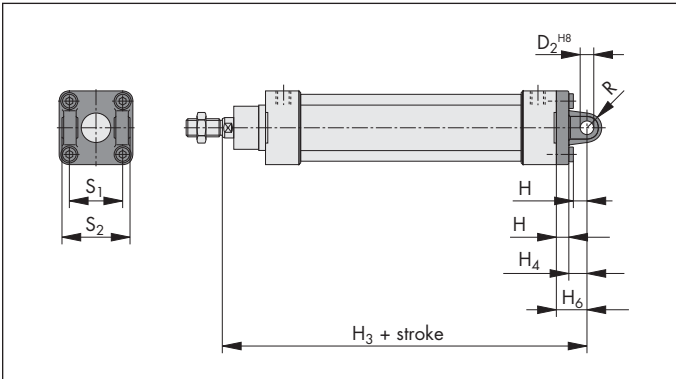

Bore ø	øD H8	H ₃ + stroke	H ₄	H ₆	H ₇	H ₈	R	S ₁	S ₂
32	0.39	5.59	0.47	0.87	0.43	0.39	0.35	1.02	1.77
	10	142	12	22	11	10	9	26	45
40	0.47	6.30	0.59	0.98	0.55	0.39	0.43	1.10	2.05
	12	160	15	25	14	10	11	28	52
50	0.47	6.69	0.63	1.06	0.59	0.43	0.47	1.26	2.36
	12	170	16	27	15	11	12	32	60
63	0.63	7.48	0.83	1.26	0.79	0.43	0.59	1.57	2.76
	16	190	21	32	20	11	15	40	70
80	0.63	8.27	0.87	1.42	0.83	0.55	0.63	1.97	3.54
	16	210	22	36	21	14	16	50	90
100	0.79	9.06	0.98	1.61	0.94	0.63	0.79	2.36	4.33
	20	230	25	41	24	16	20	60	110

Rear Single Clevis- Type BA

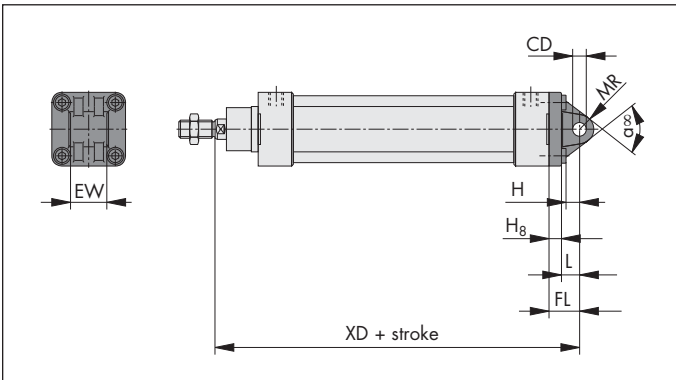

Bore ø	øCD H8	EW	FL	H ₇	H ₈	L	MR	XD+ stroke	α
32	0.39	1.02	0.87	0.43	0.39	0.47	0.41	5.59	2.36
	10	26	22	11	10	12	10.5	142	60
40	0.47	1.10	0.98	0.55	0.39	0.59	0.51	6.30	2.36
	12	28	25	14	10	15	13	160	60
50	0.47	1.26	1.06	0.59	0.43	0.63	0.51	6.69	2.76
	12	32	27	15	11	16	13	170	70
63	0.63	1.57	1.26	0.79	0.43	0.83	0.67	7.48	2.36
	16	40	32	20	11	21	17	190	60
80	0.63	1.97	1.42	0.79	0.59	0.83	0.67	8.27	2.76
	16	50	36	20	15	21	17	210	70
100	0.79	2.36	1.61	0.94	0.63	0.98	0.83	9.06	2.76
	20	60	41	24	16	25	21	230	70

Rear Single Clevis with Spherical Bearing- Type BAS

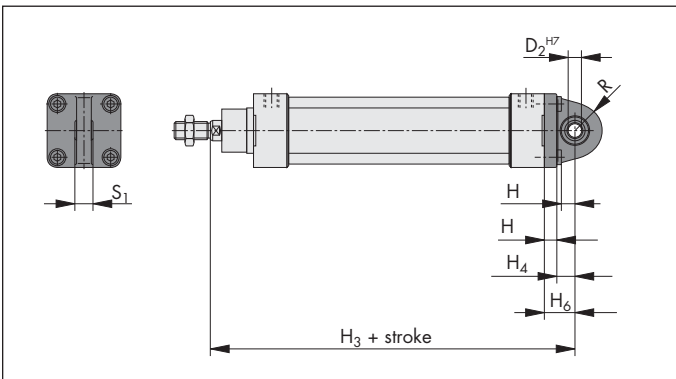

Bore ø	øD ₂ H7	H ₃ + stroke	H ₄	H ₆	H ₇	H ₈	R	S ₁
32	0.39	5.59	0.47	0.87	0.43	0.39	0.71	0.55
	10	142	12	22	11	10	18	14
40	0.47	6.30	0.59	0.98	0.55	0.39	0.83	0.63
	12	160	15	25	14	10	21	16
50	0.47	6.69	0.63	1.06	0.59	0.43	0.91	0.63
	12	170	16	27	15	11	23	16
63	0.63	7.48	0.83	1.26	0.79	0.43	1.06	0.83
	16	190	21	32	20	11	27	21
80	0.63	8.27	0.83	1.42	0.79	0.59	1.14	0.83
	16	210	21	36	20	15	29	21
100	0.79	9.06	0.98	1.61	0.94	0.63	1.34	0.98
	20	230	25	41	24	16	34	25

AZ Cylinder



Cylinder Mounts

Front Flange- Type C

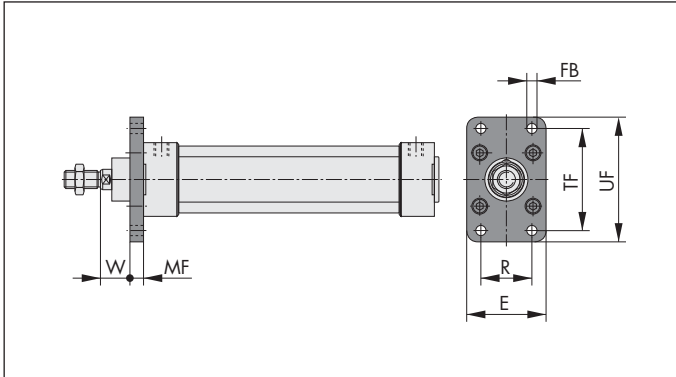

Bore \varnothing	\varnothing FB	E	MF	R	TF	UF	W
32	0.28	1.97	0.39	1.26	2.52	3.11	0.63
	7	50	10	32	64	79	16
40	0.35	2.20	0.39	1.42	2.83	3.54	0.79
	9	56	10	36	72	90	20
50	0.35	2.76	0.47	1.77	3.54	4.33	0.98
	9	70	12	45	90	110	25
63	0.35	3.03	0.47	1.97	3.94	4.72	0.98
	9	77	12	50	100	120	25
80	0.47	3.94	0.63	2.48	4.96	6.02	1.18
	12	100	16	63	126	153	30
100	0.55	4.72	0.63	2.95	5.91	7.01	1.38
	14	120	160	75	150	178	35

Rear Flange- Type D

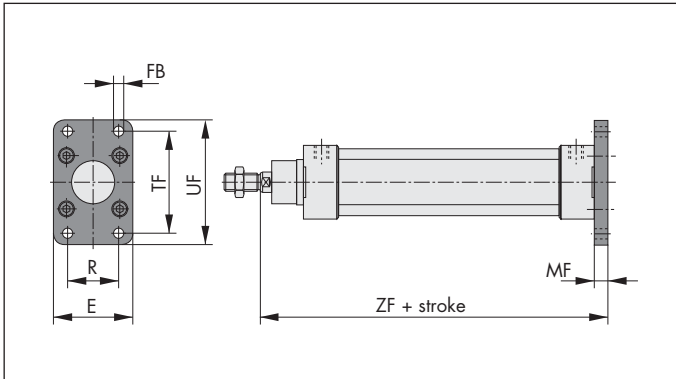

Bore \varnothing	\varnothing FB	E	MF	R	TF	UF	ZF+ stroke
32	0.28	1.97	0.39	1.26	2.52	3.11	5.12
	7	50	10	32	64	79	130
40	0.35	2.20	0.39	1.42	2.83	3.54	5.71
	9	56	10	36	72	90	145
50	0.35	2.76	0.47	1.77	3.54	4.33	6.10
	9	70	12	45	90	110	155
63	0.35	3.03	0.47	1.97	3.94	4.72	6.69
	9	77	12	50	100	120	170
80	0.47	3.94	0.63	2.48	4.96	6.02	7.48
	12	100	16	63	126	153	190
100	0.55	4.72	0.63	2.95	5.91	7.01	8.07
	14	120	16	75	150	178	205

Adjustable Trunnion- Type EN

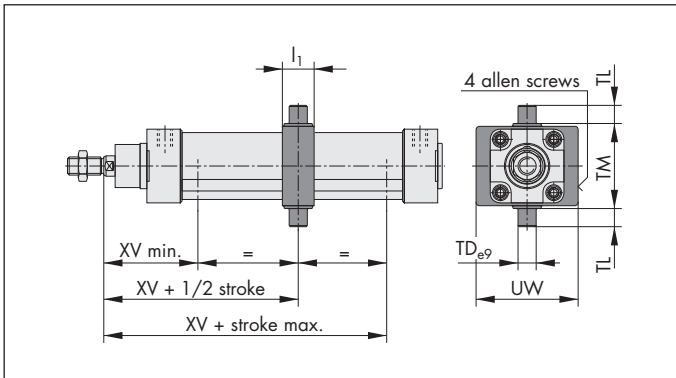

Bore \varnothing	l_1	\varnothing TD e9	TL	TM	UW	XV min.	XV+ 1/2 stroke	XV+ max. stroke
32	0.98	0.47	0.47	1.97	2.56	2.64	2.87	3.11
	25	12	12	50	65	67	73	79
40	1.10	0.63	0.63	2.48	2.95	2.83	3.27	3.70
	28	16	16	63	75	72	83	94
50	1.10	0.63	0.63	2.95	3.35	3.19	3.54	3.90
	28	16	16	75	85	81	90	99
63	1.42	0.79	0.79	3.54	3.94	3.35	3.86	4.37
	36	20	20	90	100	85	98	111
80	1.42	0.79	0.79	4.33	4.72	3.90	4.33	4.76
	36	20	20	110	120	99	110	121
100	1.89	0.98	0.98	5.20	5.31	4.21	4.72	5.24
	48	25	25	132	135	107	120	133

Trunnion Blocks- Type EL

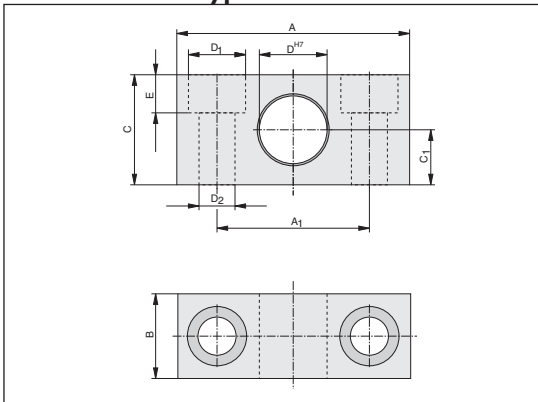

Order #	Bore \varnothing	A	A ₁	B	C	C1	\varnothing D ₁₇	\varnothing D ₁	\varnothing D ₂	E	Weight lbs (kg)
PD 23381	32	2.17	1.42	0.79	1.02	0.51	0.47	0.53	0.33	0.35	0.13
		55	36	20	26	13	12	13.5	8.4	9	0.060
PD 23382	40, 50	2.17	1.42	0.79	1.02	0.51	0.63	0.53	0.33	0.35	0.13
		55	36	20	26	13	16	13.5	8.4	9	0.060
PD 23383	63, 80	2.56	1.65	0.98	1.18	0.59	0.79	0.65	0.41	0.43	0.22
		65	42	25	30	15	20	16.5	10.5	11	0.100
PD 23384	100, 125	2.95	1.97	1.10	1.57	0.79	0.98	0.75	0.51	0.51	0.39
		75	50	28	40	20	25	19	13	13	0.175

90° Pivot Mount - to VDMA 24562

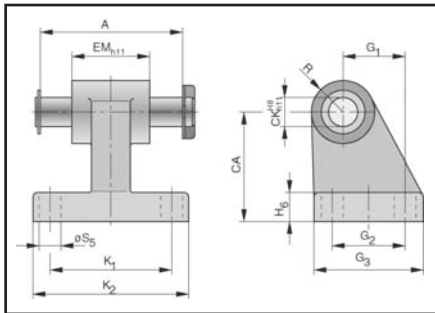

Order #	Bore Ø	A	CA	CK ^{H8} _{h11}	EM _{h11}	G ₁	G ₂	G ₃	H ₆	K ₁	K ₂	R ₁	ØS ₅	Wt. lbs (kg)
PD 40844	32	46	32	10	26	21	18	31	8	38	50	10	6.6	0.092
PD 40845	40	53	36	12	28	24	22	35	10	41	53	11	6.6	0.131
PD 40846	50	61	45	12	32	33	30	45	12	50	64	13	9	0.193
PD 40847	63	71	50	16	40	37	35	50	12	52	66	15	9	0.305
PD 40848	80	91	60	16	50	47	40	60	14	66	84	15	11	0.460
PD 40849	100	111	70	20	60	55	50	70	15	76	94	19	11	0.840

Valve Mounting Plate Ø32-100mm

Mounting Holes:

- A = 5/2-way valve; 1/4" NPT
- B = 5/2-way valve; 1/8" NPT
- C = 3/2-way valve; 1/4" NPT
- D = 3/2-way valve; 1/8" NPT

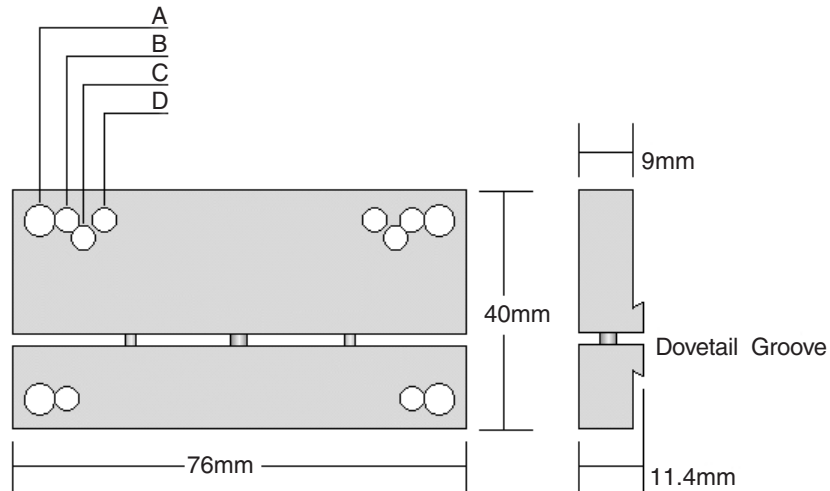

Typical Valve Installation Using Valve Mounting Plate

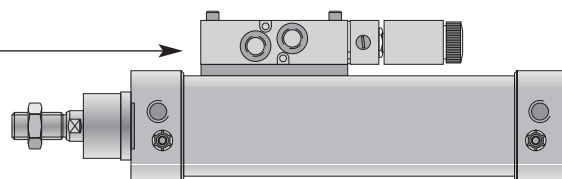

Order #: PD 40372

Ordered as a separate item
 This adapter plate is used primarily to mount our S9 series valves
 Size: 1/8" or 1/4"
 Style: 3/2-way or 5/2-way

The plate may also be used for attachment of machine components or other hardware

This adapter plate can also be used with the Series SZ, SZV, NZK, NZKV, and AZV cylinders

AZ Cylinder



Rod Mounts

Rod Clevis with Pin

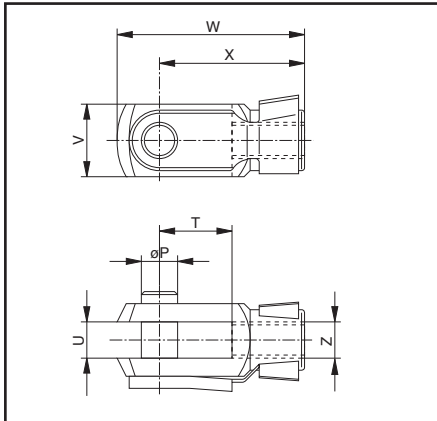

Order #	Bore Ø	Ø P	T	U	V	W	X	Z	Weight lbs (kg)
KY 6135	32	0.39 10	0.79 20	0.39 10	0.79 20	2.05 52	1.57 40	-- M10x1.25	0.18 0.08
KY 6136	40	0.47 12	0.94 24	0.47 12	0.94 24	2.44 62	1.89 48	-- M12x1.25	0.28 0.125
KY 6139	50, 63	0.63 16	1.26 32	0.63 16	1.26 32	3.27 83	2.52 64	-- M16x1.5	0.66 0.3
KY 6141	80, 100	0.79 20	1.57 40	0.79 20	1.57 40	4.13 105	3.15 80	-- M20x1.5	1.15 0.52
KY 6142	125	0.98 25	1.97 50	0.98 25	1.97 50	5.20 132 max.	3.94 100	-- M24x2	2.38 1.08
KY 6866	125	1.18 30	2.13 54	1.18 30	2.17 55	5.83 148 max.	4.41 112	-- M27x2	3.31 1.5

Rod Eye with Spherical Bearing

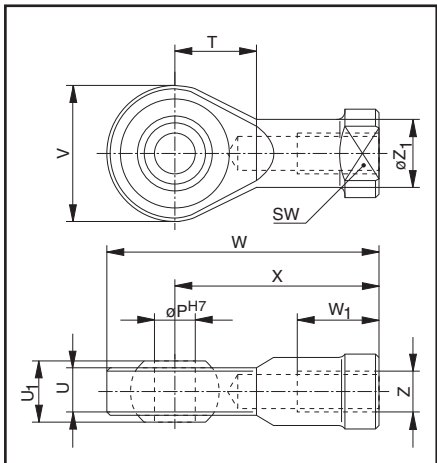

Order #	Bore Ø	Ø P _{H7}	T	U	U ₁	V	W	W ₁	X	Z	Ø Z ₁	SW	Weight lbs (kg)
KY 6147	32	0.39 10	0.59 15	0.41 10.5	0.55 14	1.10 28	2.24 57	0.79 20	1.69 43	-- M10x1.25	0.59 15	17	0.16 0.072
KY 6148	40	0.47 12	0.67 17	0.47 12	0.63 16	1.26 32	2.60 66	0.87 22	1.97 50	-- M12x1.25	0.69 17.5	19	0.24 0.107
KY 6150	50, 63	0.63 16	0.87 22	0.59 15	0.83 21	1.65 42	3.35 85	1.10 28	2.52 64	-- M16x1.5	0.87 22	22	0.46 0.21
KY 6151	80, 100	0.79 20	1.02 26	0.71 18	0.98 25	1.97 50	4.02 102	1.30 33	3.03 77	-- M20x1.5	1.08 27.5	32	0.84 0.38
KY 6152	125	0.98 25	1.22 31	0.87 22	1.22 31	2.36 60 ₁₎	4.88 124 ₁₎	1.65 42 ₂₎	3.70 94	-- M24x2	1.32 33.5	36	2.56 0.65

- 1) Maximum-dimension
- 2) Minimum-dimension

Rod Alignment Coupler

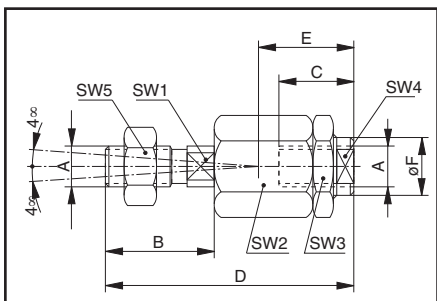

Order #	Bore Ø	A	B	C	D	E	ØF	SW1	SW2	SW3	SW4	SW5	Weight lbs (kg)
KY 1129	32 M10x1.25	0.79 20	0.91 23	2.76 70	1.22 31	0.85 21.5	12	30	30	19	17	0.01 0.218	
KY 1131	40 M12x1.25	0.91 23	0.91 23	2.64 67	1.22 31	0.85 21.5	12	30	30	19	19	0.01 0.207	
KY 1133	50 63 M16x1.5	1.57 40	1.26 32	4.41 112	1.77 45	1.32 33.5	19	41	41	30	30	0.03 0.637	
KY 1134	80 100 M20x1.5	1.54 39	1.65 42	4.80 122	2.20 56	1.32 33.5	19	41	41	30	30	0.03 0.711	

Angular Compensation

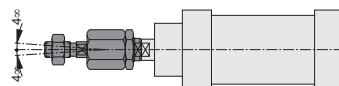

Radial Compensation for the Center Axis

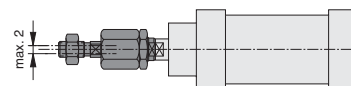

Dimensions: **Bold: INCH**, Std.: mm

AZ Cylinder



Single End Porting

-B2L Rear, Single End Porting Ø32-100mm

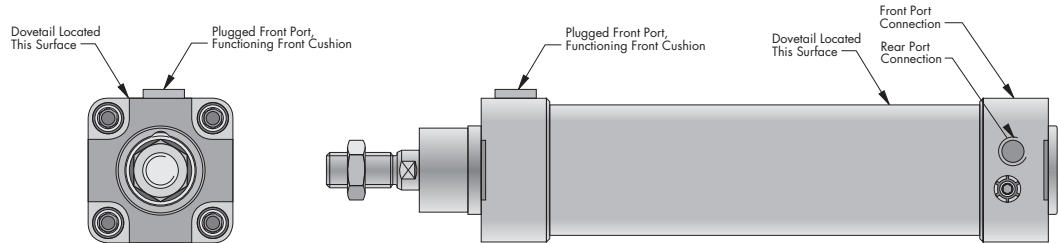

-D2L Front, Single End Porting Ø32-100mm

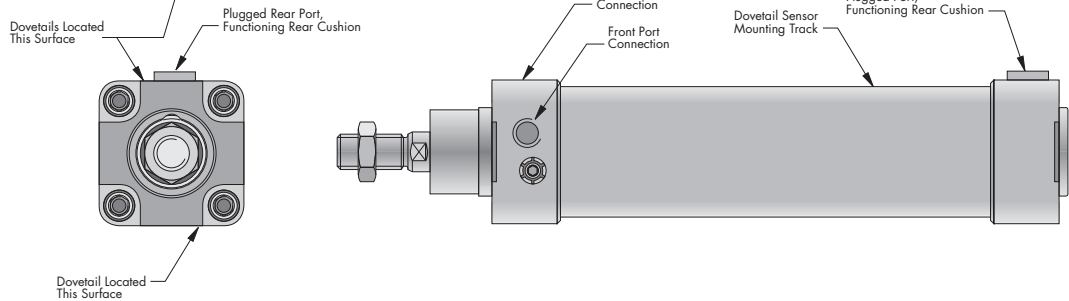

Single End Porting

Either the front or the rear end cap can be supplied with Single End Porting. An internal connection is made utilizing the galleries which have been extruded into the cylinder barrel.

The maximum potential speed of the cylinder in the retract (-B2L) or extend (-D2L) modes is limited due to the diameter of the cross-over hole in the barrel. See The following chart.

Deviation in speed (in./sec.) Ref. Cyl. AZ5XXX/6" Stroke (150mm)

Bore Ø	32mm	40mm	50mm	63mm
Extend				
Standard Cylinder	0.09	0.11	0.17	0.20
Single End Port	0.23	0.23	0.26	0.41
Retract				
Standard Cylinder	0.09	0.13	0.19	0.27
Single End Port	0.12	0.24	0.28	0.33