

Push-to-Connect Couplings

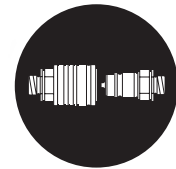

Multi Couplings



Screw-to-Connect Couplings



Germany

Walter Stauffenberg GmbH & Co. KG

Im Ehrenfeld 4

58791 Werdohl

Tel.: +49 2392 91 60

Fax: +49 2392 91 61 03

E-Mail: sales@stauff.com

www.stauff.com

STAUFF products and services are globally available through wholly-owned subsidiaries and a tight network of authorised distributors and representatives in all major industrial regions of the world.

You can find detailed contact information on the last two pages of this product catalogue or at www.stauff.com.

Please note: Unless otherwise stated, all data and figures in this product catalogue are approximate values and are only valid as references, which are not binding (also in respect to any third parties' rights of protection) and thus do not release the customer / user from checking and testing the suitability of the products for the foreseen purposes. Therefore, data and figures can only be used in a limited sense for construction purposes.

The application of the products is beyond the control possibilities of the manufacturer and, therefore, is exclusively subject to the responsibility of the customer / user.

In the event that a liability is nevertheless considered, any compensation will be limited to the value of the goods supplied by the manufacturer and used by the customer / user. As a matter of course, the manufacturer guarantees the perfect quality of all products in accordance with the General Terms and Conditions of Business and Sale.

Subject to modifications due to the ongoing development and improvement of the products.

With the publication of this product catalogue, previous editions are no longer valid.

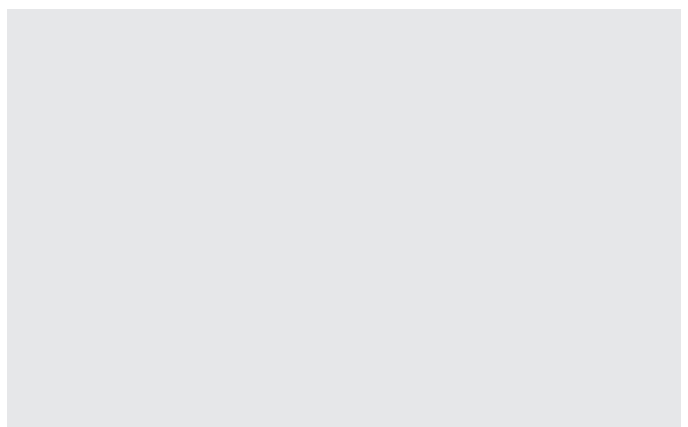
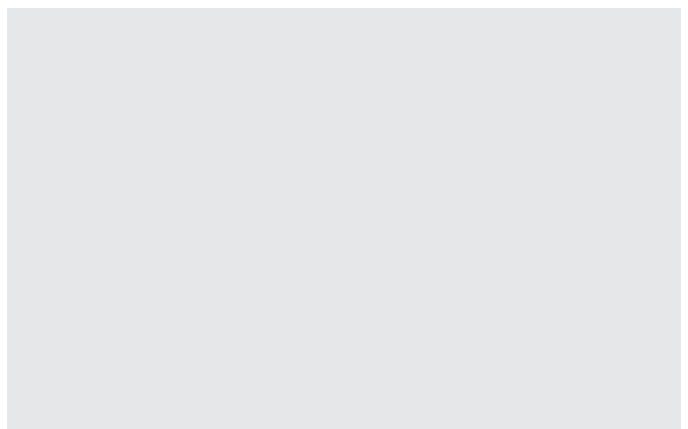

Introduction		4 - 11	
Overview (Product Overview / Structure of the Part Numbers)		12 - 19	
Push-to-Connect Couplings	FF/FH Series ▪ Flat Face Coupling acc. to ISO 16028	21 - 32	FF/FU
	FU Series ▪ Flat Face Coupling acc. to ISO 16028, Connect Under Pressure	29 - 31	
	FH Series ▪ Flat Face Coupling acc. to ISO 16028, Stainless Steel	33 - 36	FH
	FO Series ▪ Flat Face Coupling, Stainless Steel	37 - 40	FO
	HP Series ▪ ISO 7241-1, Series A, Push-Pull	41 - 52	HP/HU
	HU Series ▪ ISO 7241-1, Series A, Push-Pull, Connect Under Pressure	49	
	UX Series ▪ ISO 7241-1, Series A, Push-Pull, Connect Under Pressure	53 - 56	UX
	IA Series ▪ ISO 7241-1, Series A	57 - 62	IA
	IA Series ▪ ISO 7241-1, Series A, Stainless Steel	63 - 68	
	IB Series ▪ ISO 7241-1, Series B	69 - 74	IB
	IB Series ▪ ISO 7241-1, Series B, Brass	75 - 80	
	IB Series ▪ ISO 7241-1, Series B, Stainless Steel	81 - 86	
	ID Series	87 - 90	ID
	BP Series ▪ ISO 5676	91 - 94	BP
	HC Series ▪ Flat Face Coupling	95 - 98	HC
	HD Series ▪ Flat Face Coupling	99 - 102	HD
HUS Series	103 - 105	HUS	
Multi Couplings	MK Series ▪ Multicoupling System, Flat Face Coupling	107 - 111	MK
Screw-to-Connect Couplings	HS Series ▪ ISO 14541	113 - 124	HS
	HS Series ▪ ISO 14541, Stainless Steel	125 - 130	
	PS Series ▪ For Hammer Application	131 - 134	PS
	RH/RK Series ▪ Flat Face Coupling, Pipeline Coupling	135 - 140	RH/RK
	FT Series ▪ Flat Face Coupling, Connect Under Pressure	141 - 146	FT
	HR Series	147 - 152	HR
	HH Series	153 - 158	HH
	HH Series ▪ Stainless Steel	159 - 164	
	HI (HIB) Series ▪ ISO 14540	165 - 168	HI
	HT Series ▪ Wing Style	169 - 172	HT
HM Series ▪ Wing Style	173 - 176	HM	
HV Series ▪ Wing Style	177 - 181	HV	
Special Applications		183 - 185	
Spare Parts / Accessories		187 - 191	
Technical Appendix		193 - 195	
Appendix (Product-Specific Abbreviations / Global Contact Directory)		197 - 203	





Catalogue 1 STAUFF Clamps

- Block Clamps
- Special Clamps
- Light Series Clamps
- Saddle Clamps
- U-Bolt Clamps
- Metal Clamps
- Construction Series



Catalogue 2 STAUFF Connect

- Tube Connectors
- Assembly Tools and Devices

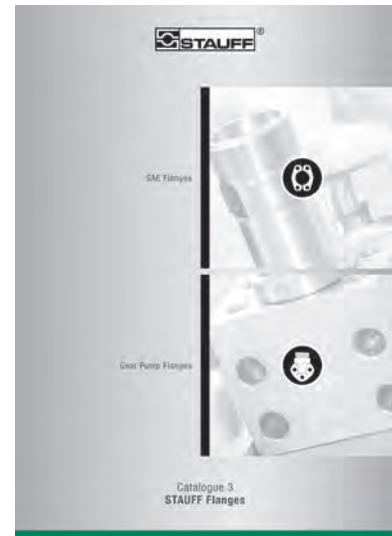

Catalogue 3 STAUFF Flanges

- SAE Flanges
- Gear Pump Flanges



Catalogue 4 STAUFF Hose Connectors

- Hose Connectors
- High-Pressure Hose Connectors



Catalogue 5 STAUFF Quick Release Couplings

- Push-to-Connect Couplings
- Multi Couplings
- Screw-to-Connect Couplings



Catalogue 6 STAUFF Valves

- Two-Way Ball Valves
- Multi-Way Ball Valves
- Flow Control and Check Valves
- Gauge Isolator Valves





Catalogue 7 STAUFF Test

- Test Couplings
- Test Adaptors
- Test Hoses and Connectors



Catalogue 8 STAUFF Diagtronics

- Pressure Gauges
- Hydraulic Testers
- Oil Analysis Equipment



Catalogue 9 STAUFF Filtration Technology

- Replacement Filter Elements
- Pressure Filters
- Return-Line Filters
- In-Line Filters
- Spin-On Filters
- Offline and Bypass Filters
- Filtration Systems

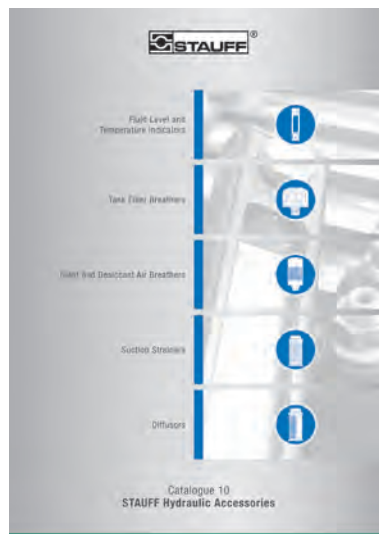

Catalogue 10 STAUFF Hydraulic Accessories

- Fluid Level and Temperature Indicators
- Tank Filler Breathers
- Giant and Desiccant Air Breathers
- Suction Strainers
- Diffusers



For more than 50 years, the companies of STAUFF Group have been developing, manufacturing and distributing pipework equipment and hydraulic components for mechanical and plant engineering and for service and industrial maintenance.

In addition to mobile and industrial hydraulic machinery, typical applications also include commercial and special purpose vehicles, rail transportation and energy technology. Likewise, STAUFF products are used in marine, oil and gas applications and in the process, food and chemical industries.

The overall range currently includes about 40000 standard products as well as numerous special and system solutions according to customer's specifications or based on our in-house development.

All STAUFF products undergo relevant testing in accordance with international regulations and are governed by the high standards of the in-house quality management system. Furthermore, many items have received certifications and approvals from various international institutes, organisations and authorities who have independently confirmed the quality and performance of the products.

Wholly-owned manufacturing, sales and service facilities in 18 countries and a tight global network of authorised distribution partners ensure high presence and service paired with a maximum of availability.



Quality Management – ISO 9001:2015
Environmental Management – ISO 14001:2015
Safety Management OHSAS – 18001:2007

STAUFF LINE Components

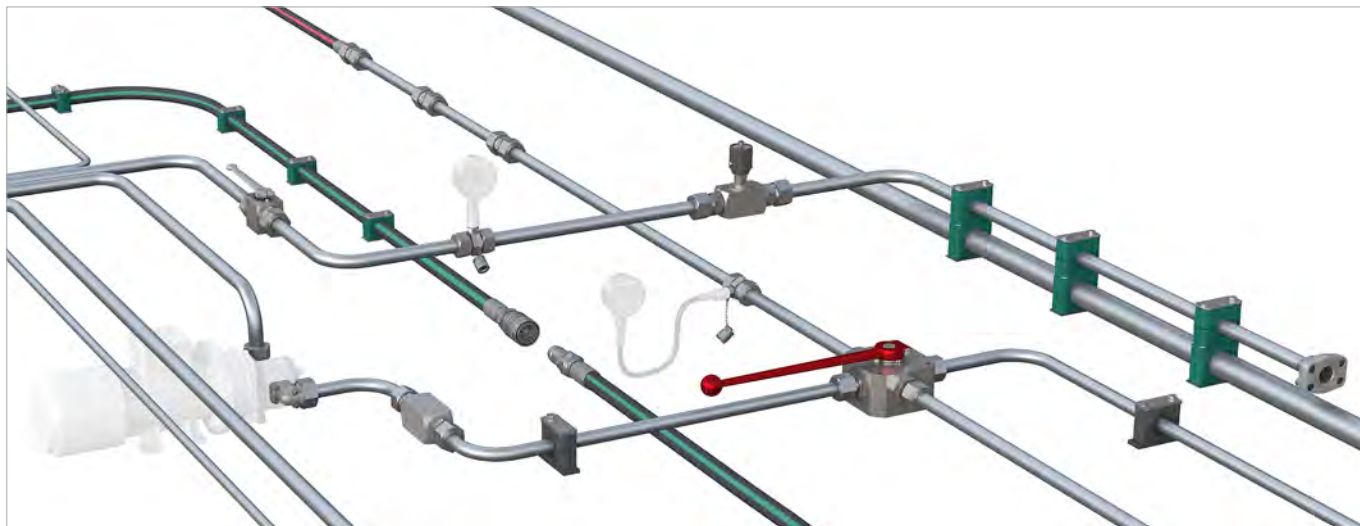

With the seven dedicated **STAUFF Line** product groups

- **STAUFF Clamps**
- **STAUFF Connect**
- **STAUFF Flanges**
- **STAUFF Hose Connectors**
- **STAUFF Quick Release Couplings**
- **STAUFF Valves**
- **STAUFF Test**

from own, in-house development and manufacturing, the companies of the STAUFF Group provide a comprehensive range of components for fastening and connecting pipes, tubes and hoses for mobile and industrial hydraulic applications and many other industries.

The portfolio is completed by components for shutting-off, regulating, throttling and measuring fluid media.

In order to perfectly match each other, STAUFF Line products are designed and offered on a high, uniform level of quality. A large proportion of the range made from steel comes as standard with the premium STAUFF Zinc/Nickel surface coating, which is also optionally available for many of the other components.

This coating offers the most reliable surface protection far beyond the previous market standards – even after transport, handling and assembly of the components – and meets all current legal requirements.

If desired, Original Equipment Manufacturers can be supported with value-added services, from **technical consultation to pre-assembly, assembly and kitting** as well as **logistics services**:

- Support with the **selection of suitable standard components** and ordering options; provision of **customised solutions** according to customer's specifications or based on our in-house development – from prototyping to large scale production
- **Analysis and optimization** of existing and design and developments of new systems aimed at increasing the efficiency and performance of machines and equipment and creating value for customers by reducing the total cost
- **Pre-assembly, assembly and kitting** of individual components to customer-specific system modules
- Individually coordinated **procurement solutions** (e.g. web shop and electronic data interchange) and **supply models** (e.g. from warehousing of customised components to Kanban logistics and just-in-time delivery of pre-fabricated system modules to the assembly lines of the customers) aimed at optimising material flows



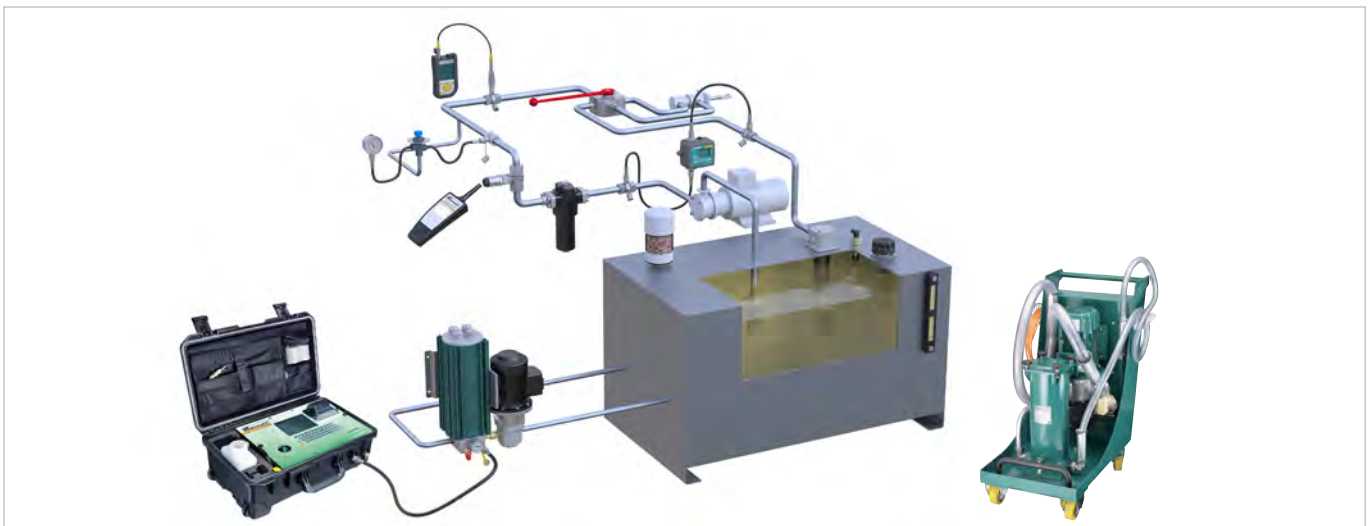

Aligned with the needs of the market, the product groups

- **STAUFF Test**
- **STAUFF Diagtronics**
- **STAUFF Filtration Technology**
- **STAUFF Hydraulic Accessories**

include a comprehensive range of analogue and digital measuring equipment and devices, filtration systems and replacement filter elements as well as accessories for the construction of tanks, reservoirs, power packs and gear boxes in mobile and industrial hydraulics.

The offer is completed by relevant value-added services:

- Support with the **selection of suitable components** and ordering options; provision of **customised solutions** according to customer's specifications or based on our in-house development – from prototyping to large scale production
- Analysis of existing hydraulic circuits aimed at filtration systems, tank components and monitoring devices that perfectly match to the specific requirements, and developing integrated concepts to increase the efficiency and performance of machines and equipment
- Individually coordinated **procurement solutions** and **supply models**



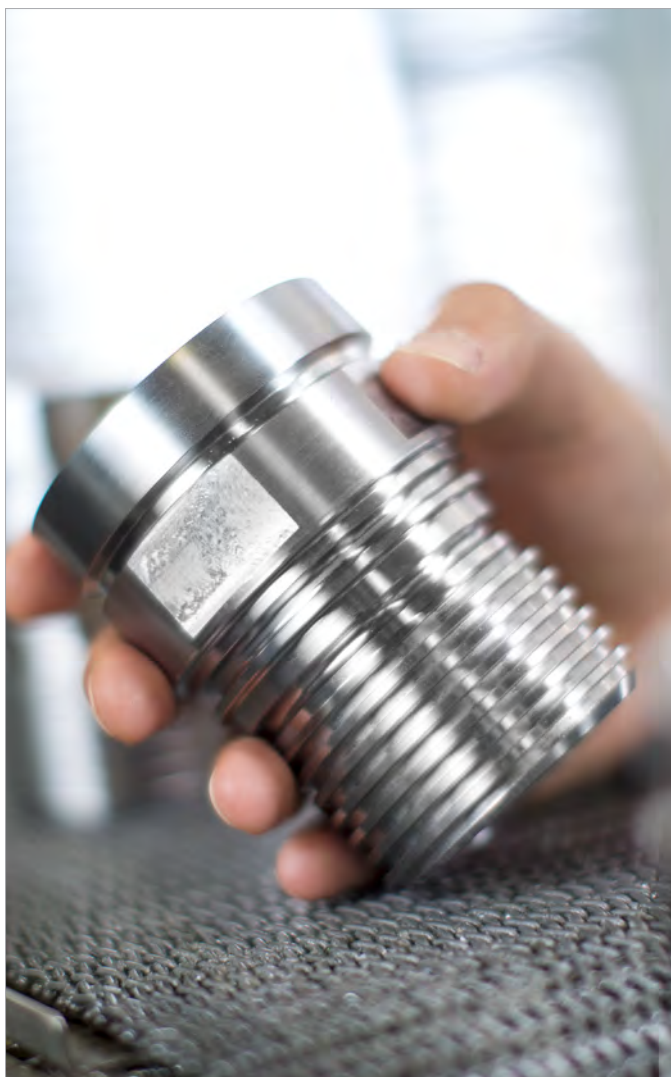

STAUFF Quick Release Couplings

STAUFF couplings have proven their value for many years in practical use in hydraulic systems. The excellent quality of the couplings is the result of continual product improvement in which the experiences of users have been taken into consideration, as well. Our high production standards, combined with our quality management system certified in accordance with EN ISO 9001, assures the quality of our products.

For the technical specifications of the individual couplings please refer to the following pages of the catalog.

Housing material

Steel according to EN 10277:
Couplings Series FF, FU, HP-10, IA, IB, ID, BP, HUS, PS, RK/RH, FT, HH, HI, HT and MK with Zinc-Nickel coating,

Zinc-Plating and Thick-Film-Passivation
(Chrome III)

Seals

NBR (Buna-N®), PTFE
ISO 3601

Operating temperature

-20 °C ... +100 °C / -4° F ... +212° F
with NBR (Buna-N®), PTFE
-25 °C ... +200 °C / -13° F ... +392° F
with FKM (Viton®)

Please contact STAUFF to require other combinations of materials.

The operating pressures specified in our catalog relate to the strength of the housing components. Standardized connector shapes may have other rated pressures, which cannot automatically be applied to the particular coupling type.

Any remodeling and modification of the couplings are prohibited. By any maintenance of our couplings it's necessary to use original STAUFF parts. In case of using of no original parts or disassembling of the couplings the warranty will be expire.

The STAUFF hydraulic couplings don't have the 94/7/EG guidance for the using in explosive field. The couplings don't have an own ignition source which could be a reason of inflame.





- Free of hexavalent chrome Cr(VI)
- ELV compliant according to 2000/53/EC (End of Life Vehicles Directive)
- REACH compliant according to 1907/2006/EC (Registration, Evaluation, Authorisation and Restriction of Chemicals)
- RoHS compliant according to 2002/95/EC (Restrictions of the Use of Hazardous Substances)

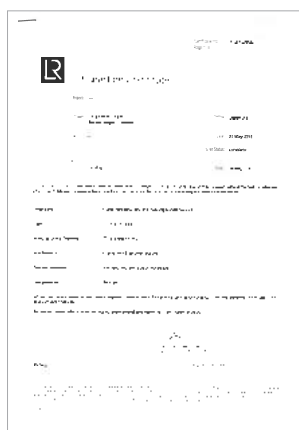

Normative references

EN ISO 8330:2000, ISO 5675, ISO 5676, ISO 7241, ISO 16028, AMD 1





www.stauff.com/catalogues

The STAUFF online catalogue centre at www.stauff.com/catalogues provides fast and direct access to digital versions of this as well as other STAUFF product catalogues in all available languages.

Online Page-Flip Catalogues

- Easy navigation through index or the powerful full text search functionality
- Contents can be shared and forwarded by e-mail, printed or downloaded and saved in PDF file format
- Also suitable for mobile devices

Download Catalogues

- Download entire product catalogues and save them in PDF file format

Catalogue Request

- Contact form to request printed copies of the product catalogue as well as digital copies on USB stick

The fastest way to the online page-flip catalogue:

The links that can be found at the bottom edge of all pages of this product catalogue will lead you directly to the corresponding page in the online page-flip catalogue.

In doing so, contents can be searched, shared and forwarded by e-mail, printed or downloaded and saved in PDF file format.

Scan the QR code next to the direct link with the camera of your mobile device* and also use the functions in this way.

* may require a suitable app





www.stauff.com

General information about the companies of STAUFF Group, latest business and product news as well as complete global contact details

www.stauff.com/cad

Immediate access to and free download of 3D models and 2D drawings for a growing number of STAUFF products

Follow STAUFF and keep yourself updated:

- 

Facebook
www.facebook.com/stauffgroup
- 

Twitter
www.twitter.com/stauffgroup
- 

LinkedIn
www.linkedin.com/company/stauff
- 

Youtube
www.youtube.com/stauffgroup



Quick Release Couplings - Overview

Working Pressure bar / PSI	Working Pressure Range											
	1250 / 18130	1000 / 14504	900 / 13054	800 / 11603	700 / 10153	600 / 8702	500 / 7252	400 / 5802	300 / 4351	200 / 2901	100 / 1450	
Series	FF/FH	FU	FH	FO	HP	HU	UX	IA	IA	IB	IB	
Material	Carbon Steel	•	•			•	•	•	•	•		
	Stainless Steel			•	•					•		
	Brass											•
Surface Finishing	Zinc-Nickel	•	•			•		•		•		
	Zinc-Plating and Thick-Film-Passivation (Chrome III)	•				•	•	•				
Standard Seal Material(s) ¹	NBR (Buna-N®)	•	•			•	•	•	•		•	
	HNBR											
	FKM (Viton®)			•	•					•		•
	PTFE	•	•	•		•		•				
PU	•	•										
Working Temperature	°C	-25 ... +100	-25 ... +100	-25 ... +200	-25 ... +200	-25 ... +100	-25 ... +100	-30 ... +100	-25 ... +100	-25 ... +200	-25 ... +100	-25 ... +200
	°F	-13 ... +212	-13 ... +212	-13 ... +392	-13 ... +392	-13 ... +212	-13 ... +212	-22 ... +212	-13 ... +212	-13 ... +392	-13 ... +212	-13 ... +392
Valve Design	Flat Face	•	•	•	•							
	Poppet Valve					•	•	•	•	•	•	•
	Ball Valve											
Connection	Push	•	•	•	•	• ²	• ²	•				
	Push and actuate Push-Pull Sleeve					•	•					
	Push and actuate Push Sleeve							•	•	•	•	•
	Screw											
Disconnection	Pull					• ²	• ²	•				
	Actuate Push-Pull Sleeve					•	•					
	Actuate Push Sleeve	•	•	•	•			•	•	•	•	•
Connect Under Pressure ⁶	Screw											
	Male Tip		• ³				• ³					
Application	Female Body							• ⁷				
	Agricultural and Forestry Machinery					•	•	•	•	•		
	Construction Machinery	•	•									
	Industrial Hydraulic	•	•	•					•	•	•	•
	Offshore				•							
Rescue and Tensioning Hydraulics												
ISO Interchange		ISO 16028	ISO 16028	ISO 16028		ISO 7241-1, Series A				ISO 7241-1, Series B		
Page		21	29/30	33	37	41	49	53	57	63	69	75

¹ Alternative seal materials are available on request.

² When mounting the Sleeve in Bulkhead

³ Up to max. 250 bar / 3626 PSI

⁴ Up to 33% of the Working Pressure with Tools

⁵ Max. 100 bar / 1450 PSI

⁶ Only Residual Pressure

⁷ Female Body with ISO-A Male Tip up to the max. Working Pressure allowed

⁸ Max. 20 bar / 290 PSI Residual Pressure with Tools



Push-to-Connect Couplings - Overview

Description	Characteristics	Series	BG	DN Zoll Inch	DN metric ISO 4397	A _{min} mm ²
Flat Face Coupling	Acc. to ISO 16028	FF-06	1	1/4"	6,3	29
		FF-10	2	3/8"	10	63
		FF-12	3	1/2"	12,5	143
		FF-16	4A	5/8"	16	127
		FF-19	4	3/4"	19	156
		FF-25	5	1"	25	251
	Male Tip Connect Under Pressure	FF-38	6	1 1/2"	31,5	350
		FH-51	7	2"	51	
		FU-10	2	3/8"	10	63
		FU-12	3	1/2"	12,5	143
		FU-19	4	3/4"	19	156
Flat Face Coupling	Acc. to ISO 16028 Stainless Steel	FH-10	2	3/8"	10	63
		FH-12	3	1/2"	12,5	143
		FH-19	6	3/4"	19	156
Flat Face Coupling	Stainless Steel	FO-06	1	1/4"	6,3	
		FO-10	2	3/8"	10	
		FO-12	3	1/2"	12,5	
		FO-19	6	3/4"	19 (20)	
		FO-25	8	1"	25	
Push-to-Connect Coupling	Acc. to ISO 7241-1, Series A Push Pull Type Breakaway Function	HP-06	1	1/4"	6,3	24
		HP-10	2	3/8"	10	45
		HP-12	3	1/2"	12,5	76
		HP-19	6	3/4"	19 (20)	130
		HP-25	8	1"	25	256
		HU-12	3	1/2"	12	
Push-to-Connect Coupling	Acc. to ISO 7241-1, Series A Push Pull Type, Breakaway Function	UX-12	3	1/2"	12,5	76
Push-to-Connect Coupling	Acc. to ISO 7241-1, Series A	IA-06	1	1/4"	6,3	
		IA-10	2	3/8"	10	
		IA-12	3	1/2"	12,5	
		IA-19	6	3/4"	19 (20)	
		IA-25	8	1"	25	
		IA-31	10	1 1/4"	31,5	
		IA-38	12	1 1/2"	38	
		IA-51	14	2"	51	
Push-to-Connect Coupling	Acc. to ISO 7241-1, Series A Stainless Steel	IA-06	1	1/4"	6,3	
		IA-10	2	3/8"	10	
		IA-12	3	1/2"	12,5	
		IA-19	6	3/4"	19 (20)	
		IA-25	8	1"	25	
		IA-31	10	1 1/4"	31,5	
		IA-38	12	1 1/2"	38	
		IA-51	14	2"	51	
Push-to-Connect Coupling	Acc. to ISO 7241-1, Series B	IB-03	0	1/8"	3,2	
		IB-06	1	1/4"	6,3	
		IB-10	2	3/8"	10	
		IB-12	3	1/2"	12,5	
		IB-19	6	3/4"	19 (20)	
		IB-25	8	1"	25	
		IB-38	12	1 1/2"	38	
		IB-51	14	2"	51	
		IB-06	1	1/4"	6,3	
		IB-10	2	3/8"	10	
Push-to-Connect Coupling	Acc. to ISO 7241-1, Series B Brass	IB-12	3	1/2"	12,5	
		IB-19	6	3/4"	19 (20)	
		IB-25	8	1"	25	
		IB-38	12	1 1/2"	38	
		IB-51	14	2"	51	
Push-to-Connect Coupling	Acc. to ISO 7241-1, Series B Stainless Steel	IB-06	1	1/4"	6,3	
		IB-10	2	3/8"	10	
		IB-12	3	1/2"	12,5	
		IB-19	6	3/4"	19 (20)	
		IB-25	8	1"	25	
		IB-38	12	1 1/2"	38	
Push-to-Connect Coupling		ID-06	1	1/4"	6,3	
		ID-10	2	3/8"	10	
		ID-19	6	3/4"	19 (20)	
		ID-25	8	1"	25	
Flat Face Coupling	Acc. to ISO 5676 For Tractor Braking System	BP-12	3	1/2"	12,5	
Flat Face Coupling	Working Pressure 1000 bar / 14504 PSI	HC-06	1	1/4"	6,3	
Flat Face Coupling	Working Pressure 1500 bar / 21756 PSI	HD-06	1	1/4"	6,3	
Flat Face Coupling		HUS-10	2	3/8"	10	
		HUS-12	3	1/2"	12,5	
		HUS-19	6	3/4"	19 (20)	
		HUS-25	8	1"	25	



Q _{max}	Working Pressure			Bursting Pressure		Female Body		Male Tip		Spillage	
	l/min	US GPM	bar	PSI	bar	PSI	bar	PSI	bar	PSI	ml
40	10.57	400	5801	1500	21756	1220	17695	2000	29007	0,01	.0003
80	21.13	350	5076	1400	20305	1100	15954	1500	21756	0,015	.0005
120	31.70	350	5076	1400	20305	1050	15229	1500	21756	0,02	.0007
150	39.63	350	5076	1600	23206	1200	17404	1200	17404	0,02	.0007
200	52.83	350	5076	1200	17404	1200	17404	1300	18854	0,032	.0011
380	100.39	260	3771	1200	17404	820	11893	1040	15083	0,03	.0010
600	158.50	300	4351	1000	14504	1000	14504	1000	14504	0,155	.0052
1000	264.17	150	2176	650	9427	650	9427	700	10153	0,1	.0034
80	21.13	350	5076	1700	24656			1500	21756	0,015	.0005
120	31.70	350	5076	1500	21756			1400	20305	0,02	.0007
180	47.55	350	5076	1600	23206			1600	23206	0,032	.0011
80	21.13	250	3626	1300	18855	750	10878	1000	14504	0,015	.0005
120	31.70	250	3626	1300	18855	750	10878	1000	14504	0,02	.0007
180	47.55	250	3626	1300	18855	750	10878	1000	14504	0,032	.0011
20	5.28	350	5076	2150	31183	1700	24656	1970	28572	0,01	.0003
45	11.89	350	5076	2000	29008	1300	18855	1400	20305	0,02	.0007
60	15.85	350	5076	2000	29008	1300	18855	1100	15954	0,03	.0010
150	39.62	350	5076	1700	24656	1280	18565	1100	15954	0,06	.0020
240	63.40	350	5076	1450	21030	1150	16679	1000	14504	0,1	.0034
20	5.28	250	3626	1000	14504	1000	14504	1000	14504	0,8	.0271
40	10.57	250	3626	1000	14504	1000	14504	1000	14504	1,2	.0406
100	21.13	250	3626	1000	14504	1000	14504	1000	14504	1,7	.0575
120	31.70	250	3626	1000	14504	1000	14504	700	10153	8,0	.2705
160	42.27	250	3626	1000	14504	1000	14504	700	10153	12,0	.4058
90	23.77	250	3626	1100	15954	1500	21756	1000	14504	2,7	.0913
100	21.13	250	3626	1000	14504	1000	14504	1000	14504	1,7	.0575
17	4.49	350	5076	1400	20305	1700	24656	1500	21756	0,5	.0169
46	12.15	275	3989	1500	21756	1500	217556	1400	20305	1,9	.0642
90	23.77	275	3989	1200	17404	1400	20305	1000	14504	2,7	.0913
190	50.19	200	2901	1000	14504	1500	21756	900	13053	9,3	.3145
280	73.97	200	2901	1000	14504	1000	14504	1300	18855	16,0	.5410
480	126.80	200	2901	1000	14504	850	12328	1100	15954	30,0	1.0144
757	199.98	130	1885	820	11893	800	11603	800	11603	54,0	1.8260
1000	264.17	130	1885	1000	14504	960	13924	650	9427	120,0	4.0577
17	4.49	450	6527	2900	42061	2900	42061	3200	46412	0,5	.0169
46	12.15	300	4351	1300	18855	1250	18130	1250	18130	1,9	.0642
90	23.77	300	4351	1350	19580	1200	17404	1200	17404	2,7	.0913
190	50.19	250	3626	1100	15954	1000	14504	800	11603	9,3	.3145
280	73.97	200	2901	850	12328	650	9427	600	8702	19,0	.6425
480	126.80	100	1450	400	5801	400	5801	400	5801	30,0	1.0144
700	184.92	80	1160	320	4641	320	4641	320	4641	54,0	1.8260
1000	264.17	60	870	250	3626	250	3626	250	3626	120,0	4.0577
9	2.38	500	7252	2700	39160	2300	29443	2400	34809	0,5	.0169
24	6.34	250	3626	1000	14504	1800	261067	1100	15954	1	.0338
46	12.15	250	3626	1300	18855	1400	20305	1400	20305	2,4	.0812
90	23.77	250	3626	1100	15954	1400	20305	1100	15954	3,9	.1319
220	58.12	250	3626	1200	17404	1300	18855	1000	14504	11,0	.3720
260	68.68	250	3626	1000	14504	1100	15954	1000	14504	19,0	.6425
757	199.98	200	2901	800	11603	800	11603	800	11603	95,0	3.2123
1000	264.17	100	1450	400	5801	400	5801	400	5801	170,0	5.7484
24	6.34	200	2901	1200	17404	800	11603	800	11603	1,0	.0338
46	12.15	200	2901	950	13779	850	12328	800	11603	2,4	.0812
90	23.77	180	2611	1000	14504	900	13053	720	10443	3,9	.1319
220	58.12	130	1885	800	11603	650	9427	550	7977	11,0	.3720
260	68.68	130	1885	600	8702	700	10153	550	7977	19,0	.6425
757	199.98	60	870	250	3626	250	3626	250	3626	95,0	3.2123
1000	264.17	50	725	200	2901	200	2908	200	2901	170	5.7484
24	6.34	350	5076	1600	23206	1500	21756	1700	24656	1,0	.0338
46	12.15	300	4351	2100	30458	1100	15954	1100	15954	2,4	.0812
90	23.77	300	4351	1500	21756	1400	20305	1500	21756	3,9	.1319
220	58.12	220	3191	1000	14504	900	13053	1000	14504	11,0	.3720
260	68.68	200	2901	850	12328	650	9427	600	8702	19,0	.6425
757	199.98	80	1160	250	3626	250	3626	250	3626	95,0	3.2123
1000	264.17	60	870	200	2901	200	2901	200	2901	170	5.7484
24	6.34	400	5801	1700	24656	1700	24656	1600	23206	1	.0338
46	12.15	350	5076	1500	21756	1700	24656	1500	21756	2,4	.0812
190	50.19	250	3626	1100	15954	1200	17404	1000	14504	8,6	.2908
250	66.04	250	3626	1000	14504	1100	15954	1200	17404	13,0	.4396
70	18.49	150	2175	930	13489	620	8992	900	13053	0,05	.0017
6	1.58	1000	14504	2500	36259	2500	36259	2500	36259	0,008	.0003
6	1.58	1500	21756	3500	50763	3500	50763	3500	50763	0,008	.0003
		350	5075	1500	21750	1450	21025	1500	21750		
		315	4567.5	1300	18850	1200	17400	1250	18125		
		300	4350	1250	18125	1200	17400	1250	18125		
		260	3770	1100	15950	1000	14500	1100	15950		



Screw-to-Connect Couplings • Overview

Description	Characteristics	Series	BG	DN Zoll Inch	DN metric ISO 4397	A _{min} mm ²		
Screw-to-Connect Coupling	Acc. to ISO 14541 (BG 1-6)	HS-06	1	1/4"	6,3	24		
		HS-10	2	3/8"	10	45		
		HS-12	3	1/2"	12,5	76		
		HS-19	6	3/4"	19	130		
		HS-25	8	1"	25	256		
		HS-38	12	1 1/2"	38	660		
Screw-to-Connect Coupling	Acc. to ISO 14541 (BG 1-6) Stainless Steel	HS-06	1	1/4"	6,3			
		HS-10	2	3/8"	10			
		HS-12	3	1/2"	12,5			
		HS-19	6	3/4"	19 (20)			
		HS-25	8	1"	25			
		HS-38	12	1 1/2"	38			
Screw-to-Connect Coupling	For Hammer Application	PS-25	08	1 1/4"	25	467		
Flat Face Coupling	Pipeline Coupling	RH-10	2	3/8"	10	55		
		RH-12	3	1/2"	12,5	105		
		RH-16	4	5/8"	16	160		
		RK-19	6	3/4"	19	285		
		RH-25	8	1"	25	620		
Flat Face Coupling	Male Tip Connect Under Pressure	FT-10	2	3/8"	10	63		
		FT-12	3	1/2"	12,5	143		
		FT-16	4	5/8"	16	139		
		FT-19	6	3/4"	19	156		
		FT-25	8	1"	25	251		
		FT-31	10	1 1/4"	31,5	506		
Screw-to-Connect Coupling		HR-10	2	3/8"	10			
		HR-12	3	1/2"	12,5			
		HR-19	6	3/4"	19 (20)			
		HR-25	8	1"	25			
		HR-31	10	1 1/4"	31,5			
		HR-38	12	1 1/2"	38			
Screw-to-Connect Coupling		HH-10	2	3/8"	10			
		HH-12	3	1/2"	12,5			
		HH-19	6	3/4"	19 (20)			
		HH-25	8	1"	25			
		HH-31	10	1 1/4"	31,5			
		HH-38	12	1 1/2"	38			
		HH-51	14	2"	51			
		HH-51	14	2"	51			
Screw-to-Connect Coupling	Stainless Steel	HH-10	2	3/8"	10			
		HH-12	3	1/2"	12,5			
Screw-to-Connect Coupling	Acc. to ISO 14540 Working Pressure 700 bar / 10153 PSI	HI-06	1	1/4"	6,3			
		HI-10	2	3/8"	10			
		HT-19	6	3/4"	19 (20)			
		HT-25	8	1"	25			
		Screw-to-Connect Coupling	Wing Style Brass and Carbon Steel	HM-19	6	3/4"	19 (20)	
				HM-25	8	1"	25	
HM-31	10			1 1/4"	31,5			
HM-38	12			1 1/2"	38			
Screw-to-Connect Coupling	Wing Style	HV-19	6	3/4"	19 (20)			
		HV-25	8	1"	25			
		HV-31	10	1 1/4"	31,5			
		HV-38	12	1 1/2"	38			
		HV-51	14	2"	51			

* short term possible



Q _{max}	Working Pressure			Bursting Pressure		Female Body		Male Tip		Spillage	
	l/min	US GPM	bar	PSI	bar	PSI	bar	PSI	bar	PSI	ml
20	5.28	450	6527	1800	26107	1400	20305	1400	20305	0,8	.0271
40	10.57	450	6527	1600	23206	1750	25382	1550	22481	1,3	.0440
80	21.13	400	5801	1400	20305	1200	17404	1200	17404	3,1	.1048
120	31.70	400	5801	1500	21756	1600	23206	1200	17404	5,6	.1894
160	42.27	300	4351	1180	17114	1500	21756	1100	15954	12,3	.4159
220	58.12	350	5076	1800	26107	1600	23206	1200	17404	52,3	1.7685
17	4.49	300	4351	1200	17404	1200	17404	1200	17404	0,8	.0271
30	7.92	250	3626	1500	21756	1400	20305	1000	14504	1,9	.0642
80	21.13	250	3626	1800	26107	1800	26107	1100	15954	2,7	.0913
106	28.00	150	2175	1700	24657	700	10153	600	8702	9,3	.3145
189	49.93	150	2175	1200	17404	600	8702	600	8702	16	.5410
350	92.46	100	1450	400	5801	400	5801	400	5801	30	1.0144
600 (1000)*	158.50	380	5511	1520	22046	1520	22046	1520	22046	27	.9130
40	10.57	420	6092	1300	18855	1350	19580	1450	21030	0,1	.0034
70	18.49	420	6092	1260	18275	1260	18275	1260	18275	0,16	.0054
105	27.77	420	6092	1260	18275	1260	18275	1260	18275	1,02	.0344
120	31.70	350	5076	1000	14504	1000	14504	1200	17404	0,86	.0291
500	132.09	420	6092	1150	16679	1100	15954	900	13053	2,84	.0960
80	21.13	550	7977	1400	20305	1100	15954	1400	20305	0,04	.0014
120	31.70	550	7977	1400	20305	1000	14504	1400	20305	0,025	.0008
140	36.98	550	7977	1400	20305	1000	14504	1600	23206		
180	47.55	500	7252	1400	20305	1050	15229	1400	20305	0,018	.0006
260	68.68	470	6817	1300	18855	1000	14504	1300	18855	0,06	.0020
600	158.50	400	5801	1100	15954	1100	15954	1100	15954		
50	13.21	610	8847	2450	35534	2450	35534	2600	37710	2	.0676
85	22.45	470	6817	1900	27557	2100	30458	1650	23931	3	.1014
120	31.70	310	4496	1250	18130	1500	21756	1250	18130	10	.3381
280	73.97	300	4351	1300	18855	1600	23206	1100	15954	16	.5410
460	121.52	300	4351	1300	18855	1300	18855	1200	17404	30	1.0144
700	184.92	270	3916	1100	15954	1500	21756	950	13779	54	1.8260
18	4.75	650	9427	3000	43511	3000	43511	3000	43511	1,9	.0642
23	6.08	600	8702	2200	31908	2700	39160	2500	36259	2,7	.0913
45	11.89	500	7252	2100	30458	2600	37710	2400	34809	9,3	.3145
106	28.00	460	6672	2000	29007	2600	37710	2300	33359	16	.5410
189	49.93	360	5221	1500	21756	1500	21756	1500	21756	30	1.0144
300	79.25	360	5221	1500	21756	1500	21756	1200	17404	54	1.8260
757	199.98	210	3046	1050	15228	1300	18855	1300	18855	120	4.0577
18	4.75	650	9427	2600	37710	2000	29008	2300	33359	1,9	.0642
23	6.08	600	8702	2500	36259	2700	39160	2100	30458	2,7	.0913
45	11.89	500	7252	2400	34809	1700	24656	2100	30458	9,3	.3145
106	28.00	460	6672	1500	21756	1900	27557	1600	23206	16	.5410
189	49.93	360	5221	1000	14504	1000	14504	1000	14504	30	1.0144
300	79.25	360	5221	900	13053	900	13053	900	13053	54	1.8260
757	199.98	210	3046	500	7252	500	7252	500	7252	120	4.0577
10	2.64	720	10443	2160	31328	2160	31328	2160	31328	0,5	.0176
20	5.28	720	10443	2160	31328	2160	31328	2160	31328	1	.0352
240	63.40	350	5076	1300	18855	1000	14504	1000	14504	10	.3381
320	84.53	300	4351	1000	14504	1000	14504	1000	14504	15	.5072
220	58.12	210	3046	1160	16824	580	8412	460	6672	0,15	.0051
260	68.68	210	3046	880	12763	720	10443	370	5366	0,4	.0135
400	105.67	190	2756	520	7542	570	8267	430	6237	0,65	.0220
600	158.50	170	2466	500	7252	350	5076	430	6237	0,85	.0287
190	50.19	350	5076	1500	21756	750	10878	1400	20305	8	.2705
280	73.97	350	5076	1600	23206	900	13053	1500	21756	16	.5410
480	126.80	350	5076	1300	18855	850	12328	1600	23206	31	1.0482
700	184.92	350	5076	1200	17404	600	8702	900	13053	64	2.1641
1000	264.17	350	5076	1100	15954	500	7252	600	8702	141	4.7678



Structure of the old Ordering Codes

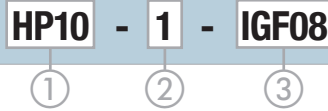

① Type and DN				
Push-to-Connect Couplings	FF/FH	Flat Face Coupling acc. to ISO 16028	Push-to-Connect Couplings	
	FU	Flat Face Coupling acc. to ISO 16028, Connect Under Pressure	Multi Couplings	
	FH	Flat Face Coupling acc. to ISO 16028, Stainless Steel	Screw-to-Connect Couplings	
	FO	Flat Face Coupling, Stainless Steel		
	HP	ISO 7241-1, Series A, Push-Pull		
	UX	ISO 7241-1, Series A, Push-Pull, Connect Under Pressure		
	IA	ISO 7241-1, Series A		
	IA	ISO 7241-1, Series A, Stainless Steel		
	IB	ISO 7241-1, Series B		
	IB	ISO 7241-1, Series B, Brass		
	IB	ISO 7241-1, Series B, Stainless Steel		
	ID	Push-to-Connect Coupling		
	BP	ISO 5676		
	HC	Flat Face Coupling		
	HD	Flat Face Coupling		
		HUS		
		MK		Multicoupling System, Flat Face Coupling
		HS	ISO 14541	
		HS	ISO 14541, Stainless Steel	
		PS	For Hammer Application	
		RH/RK	Flat Face Coupling, Pipeline Coupling	
		FT	Flat Face Coupling, Connect Under Pressure	
		HR	Screw-to-Connect Coupling	
		HH	Screw-to-Connect Coupling	
		HH	Stainless Steel	
		HI	ISO 14540	
		HT	Wing Style	
		HM	Wing Style	
		HV	Wing Style	

② Component of Coupling	
0	Dust Cap
1	Female Body with Valve
2	Male Tip with Valve
3	Female Body with Dust Plug
4	Male Tip with Dust Cap
5	Female Body with fixed Dust Protection
6	Male Tip without Valve
7	Female Body without Valve
8	Complete Coupling
9	Dust Plug

③ Type of Connection	
AGF	Male thread BSP acc. to DIN 3852
AMF	Male thread metric acc. to DIN 3852
IGF	Female thread BSP acc. to DIN 3852
IMF	Female thread metric acc. to DIN 3852
INF	Female thread NPTF
IUF	Female thread UNF
L	24 ° cone / DIN 2353 light series
S	24 ° cone / DIN 2353 heavy series
N	24 ° cone / DIN 2353 light series, bulkhead
T	24 ° cone / DIN 2353 heavy series, bulkhead
AFS	Flange acc. SAE
SL	Hose Connection
SUO	Male thread ORFS, SAE 1453



Structure of the STAUFF Ordering Codes

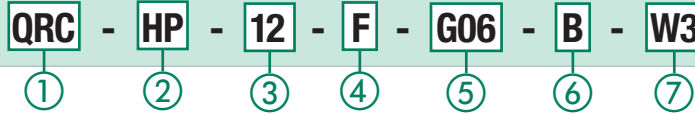

① Quick Release Coupling (QRC)

② Coupling Series				
Push-to-Connect Couplings	FF/FH	Flat Face Coupling acc. to ISO 16028	Push-to-Connect Couplings	HUS
	FU	Flat Face Coupling acc. to ISO 16028, Connect Under Pressure	Multi Couplings	MK
	FH	Flat Face Coupling acc. to ISO 16028, Stainless Steel		HS
	FO	Flat Face Coupling, Stainless Steel		HS
	HP	ISO 7241-1, Series A, Push-Pull		PS
	UX	ISO 7241-1, Series A, Push-Pull, Connect Under Pressure		RH/RK
	IA	ISO 7241-1, Series A		FT
	IA	ISO 7241-1, Series A, Stainless Steel	Screw-to-Connect Couplings	HR
	IB	ISO 7241-1, Series B		HH
	IB	ISO 7241-1, Series B, Brass		HH
	IB	ISO 7241-1, Series B, Stainless Steel		HI
	ID	Push-to-Connect Coupling		HT
	BP	ISO 5676		HM
	HC	Flat Face Coupling		HV
	HD	Flat Face Coupling		

③ Coupling Size																	
STAUFF	ISO 4397	Size	Flange		Metric Ports						Imperial Ports						
			ISO 6162-1	ISO 6261-2	DIN EN ISO 8434-1		EN ISO 6149		EN ISO 9974		ISO 1179 BSP		SAE J514	SAE J1453	SAE J1926-1	ANSI B 1.20.1	
			350 bar (3000 PSI)	420 bar (6000 PSI)	Light series	Heavy series	Light series	Heavy series	Light series	Heavy series	Light series	Heavy series	UN / UNF	UN / UNF	UN / UNF	NPT / NPTF	
Nominal Size	DN	Inch										JIC 37°	ORS				
03	3,2	1/8					M8x1	M10x1									
04	4				M12x1,5-6	M14x1,5-6	M10x1	M12x1,5	M10x1	M12x1,5	G 1/8					1/8-27	
05	5	3/16				M16x1,5-10	M16x1,5-8			M12x1,5	M14x1,5	G 1/4		7/16-20	9/16-18	7/16-20	
06	6,3	1/4				M14x1,5-8	M18x1,5-10	M12x5	M14x1,5	M14x1,5	M16x1,5	G 1/4		1/2-20	1 1/16-16		1/4-18
08	8	5/16				M16x1,5-10	M20x1,5-12	M16x1,5	M18x1,5	M16x1,5	M18x1,5	G 3/8		9/16-18		9/16-18	
10	10	3/8				M18x1,5-12	M22x1,5-14	M18x1,8	M18x1,5	M18x1,5	M20x1,5	G 3/8		3/4-16	1 3/16-16	3/4-16	3/8-18
12	12,5	1/2	13 (1/2")	13 (1/2")	M22x1,5-15	M24x1,5-16	M22x1,5	M22x1,5	M22x1,5	M22x1,5	G 1/2	G 1/2	7/8-14	1-14	7/8-14	1/2-14	
16	16	5/8				M26x1,5-18	M30x2-20	M27x2	M30x2		M27x2	G 3/4	G 3/4	1 1/16-12	1 3/16-12	1 1/16-12	
19	19	3/4	19 (3/4")	19 (3/4")	M30x2-20	M36x2-25	M30x2	M33x2	M26x1,5	M33x2	M42x2	G 3/4	G 1	1 5/16-12	1 7/16-12	1 5/16-12	3/4-14
25	25	1	25 (1")	25 (1")	M36x2-25	M42x2-30	M33x2	M42x2	M33x2	M42x2	G 1	G 1 1/4	1 5/8-12	1 11/16-12	1 5/8-12	1-11,5	
31	31,5	1 1/4	32 (1 1/4")	32 (1 1/4")	M45x2-35	M52x2-38	M42x2	M48x2	M42x2	M48x2	G 1 1/4	G 1 1/2	1 7/8-12	2-12	1 7/8-12	1 1/4-11,5	
38	38	1 1/2	38 (1 1/2")	38 (1 1/2")	M52x2-42		M48x2	M60x2			G 1 1/2	G 2	2 1/2-12			1 1/2-11,5	
51	51	2	51 (2")	51 (2")										3-12		2-11,5	
63	63	2 1/2	64 (2 1/2")	64 (2 1/2")										3 1/2-12			

④ Component of Coupling				⑤ Type of Connection			
CC	Complete Coupling	BF	Dust Cover Body with flip-lid	Gxx	BSP Female thread ISO 1179	F6xx	Flange head 420 bar (6000 PSI), ISO 6262-2
F	Female Body with Valve	HM	Male Tip holder (parking station for Male Tip)	Bxx	BSP Male thread ISO 1179	F3xx	Flange head 350 bar (3000 PSI), ISO 6162-1
FD	Female Body with Dust Plug / Cap	BH	Breakaway holder	NFxx	NPTF Female thread ANSI B 1.20.3	UxxM	UNF Male ORB thread SAE J1926-1, ISO 11926
FF	Female Body with fixed Dust Cover flap lid	FSK	Female Body Sealing Kit	Uxx	UNF Female thread SAE J1926-1, ISO 11926		
M	Male Tip with Valve	MSK	Male Tip Sealing Kit	MxxM	Metric Male thread ISO 6149		
MW	Male Tip without Valve	FP	Fixed part	Mxx	Metric Female thread ISO 6149		
MD	Male Tip with Dust Cap / Plug	MP	Mobile part	xxL	Metric Male thread with 24° cone Light series ISO 8434-1		
DF	Dust Cap/ Plug for Female Body	LV	Lock Valve	xxN	Metric Male thread with 24° cone Light series, ISO 8434-1, Bulkhead		
DM	Dust Cap/ Plug for Male Tip	SP	Spare parts	xxS	Metric Male thread with 24° cone Heavy series ISO 8434-1		
SF	Slip-on flap lid	FW	Female Body without Valve	xxT	Metric Male thread with 24° cone Heavy series, ISO 8434-1, Bulkhead		

⑥ Sealing Material			
B	NBR (Buna-N®)	BV	NBR (Buna-N®) + FKM (Viton®)
PT	PTFE (Teflon)	VP	FKM (Viton®) + PU (Polyurethan)
V	FKM (Viton®)	S1	NBR (Buna-N®) + PU (Polyurethan) + PTFE (Teflon)
E	EPDM (Ethylen-Propylen Dien-Kautschuk)	S2	NBR (Buna-N®) + PU (Polyurethan) + PTFE (Teflon) + FKM (Viton®)
PU	Polyurethan	HB	High emperature NBR
BT	NBR (Buna-N®) + PTFE (Teflon)	HV	High temperature NBR + FKM (Viton®)
VT	FKM (Viton®) + PTFE (Teflon)	S3	High temperature NBR + FKM (Viton®) + PTFE (Teflon)
BP	NBR (Buna-N®) + PU (Polyurethan)	S4	NBR (Buna-N®) + FKM (Viton®) + PTFE (Teflon)

⑦ Surface / Material			
W3	Steel, zinc-nickel plated	W89	Aluminium exloxtated
W4	Stainless Steel V2A	W126	Aluminium exloxtated and Stainless Steel V2A
W5	Stainless Steel V4A	W138	Steel, zinc-nickel plated and zinc (with Chrome VI) plated
W48	Steel, zinc plated (with Chrome VI, A3C)	W139	Brass and Plastic
W66	Steel chromium VI-free zinc plated plus thick-layer-passivation (contents CrIII)	W162	Brass and Steel chromium VI-free zinc plated plus thick-layer-passivation (contents CrIII)
W69	Brass	K	Plastic





Series FF/ FH/ FU ▪ Carbon Steel

Series FF/FH/FU ▪ Overview	22	Series FF-38 ▪ BG 6 ▪ Nominal Size 31,5	29
Series FF-06 ▪ BG 1 ▪ Nominal Size 6,3	23	Series FH/FU 51 ▪ BG 7 ▪ Nominal Size 50	29
Series FF-10 ▪ BG 2 ▪ Nominal Size 10	24	Series FU-10 ▪ BG 2 ▪ Nominal Size 10 Connect Under Pressure	30
Series FF-12 ▪ BG 3 ▪ Nominal Size 12,5	25	Series FU-12 ▪ BG 3 ▪ Nominal Size 12,5 Connect Under Pressure	30
Series FF-16 ▪ BG 4A ▪ Nominal Size 16	26	Series FU-19 ▪ BG 4 ▪ Nominal Size 19 Connect Under Pressure	30
Series FF-19 ▪ BG 4 ▪ Nominal Size 19	27	Series FF/FH/FU ▪ Dust Protection	31
Series FF-25 ▪ BG 5 ▪ Nominal Size 25	28		

FF/FU
FH

Series FF/ FH/ FU • Carbon Steel

Material	Carbon Steel
Surface Finishing	Zinc-Nickel, Zinc-Plating and Thick-Film-Passivation (Chrome III) only FF/FU 51
Standard Seal Material(s)	NBR (Buna-N®), PTFE, PU ²
Working Temperature	-25° C ... +100° C / -13° F ... +212° F
Valve Design	Flat Face
Connection	Push
Disconnection	Actuate Push Sleeve
Connect Under Pressure	not allowed, (Male Tip Series FU up to the max. Working Pressure allowed)
Application	Construction Machinery, Industrial Hydraulic
ISO Interchange	ISO 16028



FF/FU

FH

²Alternative seal materials are available on request.

Technical Data

Series	BG	DN Zoll	DN metric ISO 4397	Q _{max}		Working Pressure*		Bursting Pressure Connected		Female Body		Male Tip		Spillage	
				l/min	US GPM	bar	PSI	bar	PSI	bar	PSI	bar	PSI	ml	fl oz
FF-06	1	1/4"	6,3	40	10.57	400	5801	1500	21756	1220	17695	2000	29007	0,01	.0003
FF-10	2	3/8"	10	80	21.13	350	5076	1400	20305	1100	15954	1500	21756	0,015	.0005
FF-12	3	1/2"	12,5	120	31.70	350	5076	1400	20305	1050	15229	1500	21756	0,02	.0007
FF-16	4A	5/8"	16	150	39.63	350	5076	1600	23206	1200	17404	1200	17404	0,02	.0007
FF-19	4	3/4"	19	200	52.83	350	5076	1200	17404	1200	17404	1300	18854	0,032	.0011
FF-25	5	1"	25	380	100.39	260	3771	1200	17404	820	11893	1040	15083	0,03	.0010
FF-38	6	1 1/2"	38	600	158.50	300	4351	1000	14504	1000	14504	1000	14504	0,155	.0052
FH-51	7	2"	51	1000	264.17	150	2176	650	9427	650	9427	700	10153	0,1	.0034
FU-10	2	3/8"	10	80	21.13	350	5076	1700	24656			1500	21756	0,015	.0005
FU-12	3	1/2"	12,5	120	31.70	350	5076	1500	21756			1400	20305	0,02	.0007
FU-19	4	3/4"	19	180	47.55	350	5076	1600	23206			1600	23206	0,032	.0011

The indicated pressure ratings only apply to the coupling itself and depend on the connection type.

Flow Characteristics

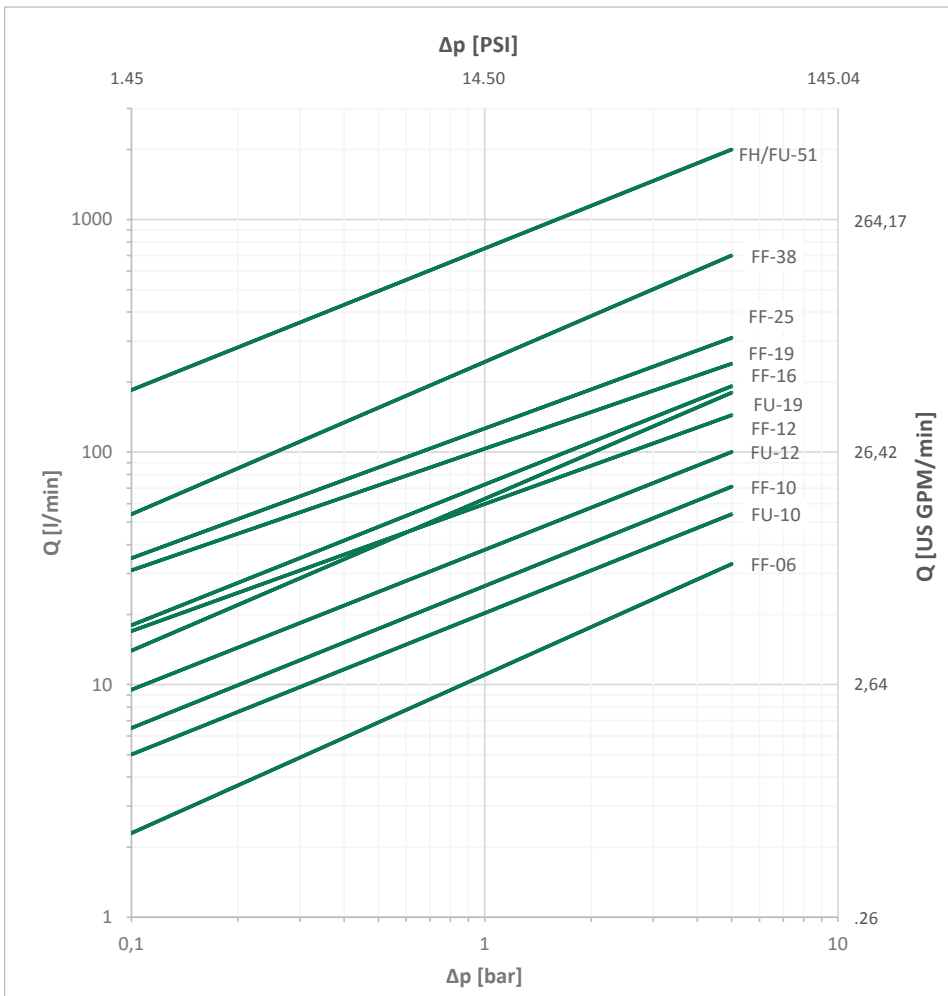

Please note: Unless otherwise stated, all flow characteristics have been determined with hydraulic oil with a kinematic viscosity of 28,8 - 35,2 mm²/s (28,8 - 35,2 cSt) and are only valid for components with non-reducing connections.



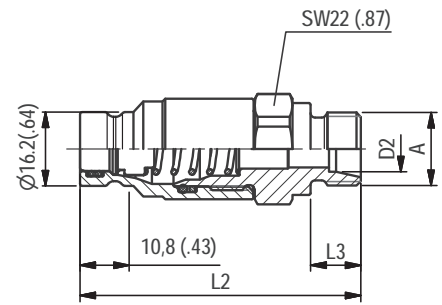
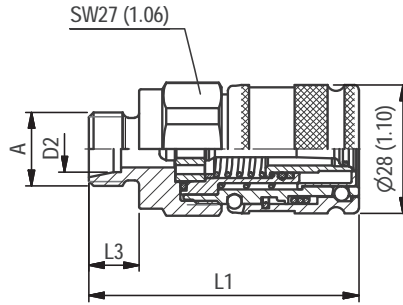

SW: Width across flats. All dimensions in mm (inch).

FF/FU
FH
Series FF-06 • BG 1 • Nominal Size 6,3

Port A	Dimensions (^{mm} / _{in})					Female Body	Weight	Male Tip	Weight
	ØD2	L1	L2	L3	L4	Old Part Numbers STAUFF Ordering Codes	(^{kg} / _{lbs}) ca. per 100	Old Part Numbers STAUFF Ordering Codes	(^{kg} / _{lbs}) ca. per 100
Female Thread according to DIN 3852 - ANSI B 1.20.3 - SAE J1926-1									
	G 1/4"	55	54		12	FF06-1-IGF04 QRC-FF-06-F-G04-BT-W3	21,20 46.74	FF06-2-IGF04 QRC-FF-06-M-G04-S1-W3	10,20 22.49
	NPTF 1/4"-18	55	54			FF06-1-INF04 QRC-FF-06-F-NF04-BT-W3	22,10 48.72	FF06-2-INF04 QRC-FF-06-M-NF04-S1-W3	10,60 23.37
	UNF 9/16"-18	55	52		12,8	FF06-1-IUF06 QRC-FF-06-F-U06-BT-W3	21,30 46.96	FF06-2-IUF06 QRC-FF-06-M-U06-S1-W3	10,30 22.71
Male Thread with 24° Conical Bore - Shape W according to DIN 3861									
	M14x1,5	8L	57	60	10	FF06-1-L0814 QRC-FF-06-F-08L-BT-W3	18 39.68	FF06-2-L0814 QRC-FF-06-M-08L-S1-W3	10,20 22.49
			2.24	2.36	.39				
	M16x1,5	10L	59	61	11	FF06-1-L1016 QRC-FF-06-F-10L-BT-W3	18,20 40.12	FF06-2-L1016 QRC-FF-06-M-10L-S1-W3	10,60 23.40
2.32			2.40	.43					
Male Thread with 24° Conical Bore - Bulkhead - Shape W according to DIN 3861									
	M14x1,5	8L	73	75	25	FF06-1-N0814 QRC-FF-06-F-08LB-BT-W3	19,40 42.77	FF06-2-N0814 QRC-FF-06-M-08LB-S1-W3	10,30 22.71
			2.87	2.95	.98				
	M16x1,5	10L	74	76	26	FF06-1-N1016 QRC-FF-06-F-10LB-BT-W3	20 44.09	FF06-2-N1016 QRC-FF-06-M-10LB-S1-W3	10,90 24.03
2.91			2.99	1.02					

Note: The connection of the two halves of a coupling is achieved depending on the type. It is important to observe the positive engagement of plug-type couplings and the secure tightening of screw-type couplings to the limit stop of the thread. Forced or improper separation will result in malfunction of the coupling.



FF/FU
FH

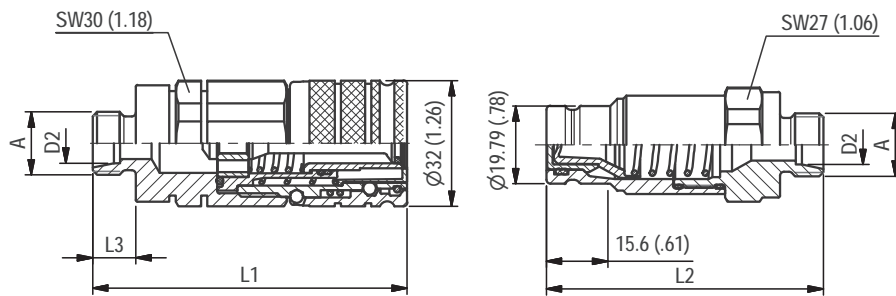

SW: Width across flats. All dimensions in mm (inch).

Series FF-10 ▪ BG 2 ▪ Nominal Size 10

Port A	Dimensions (^{mm} / _{in})					Female Body	Weight	Male Tip	Weight
	ØD2	L1	L2	L3	L4	Old Part Numbers STAUFF Ordering Codes	(^{kg} / _{lbs}) ca. per 100	Old Part Numbers STAUFF Ordering Codes	(^{kg} / _{lbs}) ca. per 100
Female Thread according to DIN 3852-2 - ISO 6149-1 - ANSI B 1.20.3- SAE J1926-1									
	G 3/8"	69	64,9		14,2	FF10-1-IGF06 QRC-FF-10-F-G06-BT-W3	28,50 62.83	FF10-2-IGF06 QRC-FF-10-M-G06-BP-W3	12,70 28
	G 1/2"	69	64,9		14,2	FF10-1-IGF08 QRC-FF-10-F-G08-BT-W3	27 59.52	FF10-2-IGF08 QRC-FF-10-M-G08-BP-W3	12,10 26.68
	NPTF 3/8"-18	69	64,9			FF10-1-INF06 QRC-FF-10-F-NF06-BT-W3	28,70 63.27	FF10-2-INF06 QRC-FF-10-M-NF06-BP-W3	12,90 28.44
	NPTF 1/2"-14	70	62,9			FF10-1-INF08 QRC-FF-10-F-NF08-BT-W3	28 61.73	FF10-2-INF08 QRC-FF-10-M-NF08-BP-W3	13,70 30.20
	UNF 3/4"-16	69	62,9		14,3	FF10-1-IUF08 QRC-FF-10-F-U08-BT-W3	27,50 60.63	FF10-2-IUF08 QRC-FF-10-M-U08-BP-W3	13,80 30.42
		2.72	2.48		.56				
Male Thread with 24° Conical Bore - Shape W according to DIN 3861									
	M16x1,5	10L	80	70,4	11	FF10-1-L1016 QRC-FF-10-F-10L-BT-W3	30 66.14	FF10-2-L1016 QRC-FF-10-M-10L-BP-W3	14,70 32.41
		12L	80	70,4	11	FF10-1-L1218 QRC-FF-10-F-12L-BT-W3	30 66.14	FF10-2-L1218 QRC-FF-10-M-12L-BP-W3	14,70 32.41
	M22x1,5	15L	81	71,4	12	FF10-1-L1522 QRC-FF-10-F-15L-BT-W3	30,70 67.68	FF10-2-L1522 QRC-FF-10-M-15L-BP-W3	15,20 33.51
		12S	81	71,4	12	FF10-1-S1220 QRC-FF-10-F-12S-BT-W3	30,90 68.12	FF10-2-S1220 QRC-FF-10-M-12S-BP-W3	15,40 33.95
	M24x1,5	16S	83	73,4	14	FF10-1-S1624 QRC-FF-10-F-16S-BT-W3	31,60 69.67	FF10-2-S1624 QRC-FF-10-M-16S-BP-W3	15,90 35.05
		3.19	2.81	.47					
Male Thread with 24° Conical Bore - Bulkhead - Shape W according to DIN 3861									
	M16x1,5	10L	87	85,4	26	FF10-1-N1016 QRC-FF-10-F-10LB-BT-W3	286 629.20	FF10-2-N1016 QRC-FF-10-M-10LB-BP-W3	165 363.00
		12L	87	85,4	26	FF10-1-N1218 QRC-FF-10-F-12LB-BT-W3	289 635.80	FF10-2-N1218 QRC-FF-10-M-12LB-BP-W3	168 369.60
	M22x1,5	15L	88	86,4	27	FF10-1-N1522 QRC-FF-10-F-15LB-BT-W3	306 673.20	FF10-2-N1522 QRC-FF-10-M-15LB-BP-W3	184 404.80
		12S	88	86,4	27	FF10-1-T1220 QRC-FF-10-F-12SB-BT-W3	308 678.48	FF10-2-T1220 QRC-FF-10-M-12SB-BP-W3	186 408.10
	M24x1,5	16S	89,6	88,4	29	FF10-1-T1624 QRC-FF-10-F-16SB-BT-W3	324 712.80	FF10-2-T1624 QRC-FF-10-M-16SB-BP-W3	199 438.46
		3.53	3.48	1.14					

Note: The connection of the two halves of a coupling is achieved depending on the type. It is important to observe the positive engagement of plug-type couplings and the secure tightening of screw-type couplings to the limit stop of the thread. Forced or improper separation will result in malfunction of the coupling.



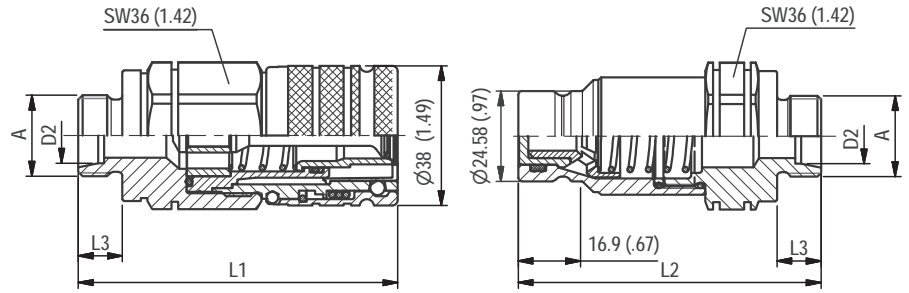

SW: Width across flats. All dimensions in mm (inch).

Series FF-12 ▪ BG 3 ▪ Nominal Size 12,5

Port A	Dimensions (^{mm} / _{in})					Female Body	Weight	Male Tip	Weight	
	ØD2	L1	L2	L3	L4	Old Part Numbers STAUFF Ordering Codes	(^{kg} / _{lbs}) ca. per 100	Old Part Numbers STAUFF Ordering Codes	(^{kg} / _{lbs}) ca. per 100	
Female Thread according to DIN 3852-2 - ISO 6149-1 - ANSI B 1.20.3- SAE J1926-1										
	G 1/2"	84	71		14	FF12-1-IGF08 QRC-FF-12-F-G08-BT-W3	50 110.23	FF12-2-IGF08 QRC-FF-12-M-G08-BP-W3	25,50 56.22	
	G 3/4"	84	72		18	FF12-1-IGF12 QRC-FF-12-F-G12-BT-W3	46,60 102.74	FF12-2-IGF12 QRC-FF-12-M-G12-BP-W3	23,50 51.81	
	NPTF 1/2"-14	84	71			FF12-1-INF08 QRC-FF-12-F-NF08-BT-W3	50,70 111.77	FF12-2-INF08 QRC-FF-12-M-NF08-BP-W3	26 57.32	
	NPTF 3/4"-14	84	72			FF12-1-INF12 QRC-FF-12-F-NF12-BT-W3	47,70 105.16	FF12-2-INF12 QRC-FF-12-M-NF12-BP-W3	24,10 53.13	
	UNF 3/4"-16	84	72		14,3	FF12-1-IUF08 QRC-FF-12-F-U08-BT-W3	50,90 112.22	FF12-2-IUF08 QRC-FF-12-M-U08-BP-W3	26,30 57.98	
	UNF 7/8"-14	84	72		16,7	FF12-1-IUF10 QRC-FF-12-F-U10-BT-W3	49 108.03	FF12-2-IUF10 QRC-FF-12-M-U10-BP-W3	25,30 55.78	
	UN 1" 1/16-12	84	76		19	FF12-1-IUF12 QRC-FF-12-F-U12-BT-W3	45,60 100.53	FF12-2-IUF12 QRC-FF-12-M-U12-BP-W3	24,50 54.01	
	Male Thread with 24° Conical Bore - Shape W according to DIN 3861									
	M18x1,5	12L	86	81,5	11	FF12-1-L1218 QRC-FF-12-F-12L-BT-W3	48,10 106.04	FF12-2-L1218 QRC-FF-12-M-12L-BP-W3	27,70 61.07	
	M22x1,5	15L	87	82,5	12	FF12-1-L1522 QRC-FF-12-F-15L-BT-W3	48,60 107.14	FF12-2-L1522 QRC-FF-12-M-15L-BP-W3	28,40 62.61	
	M26x1,5	18L	87	82,5	12	FF12-1-L1826 QRC-FF-12-F-18L-BT-W3	47,60 104.94	FF12-2-L1826 QRC-FF-12-M-18L-BP-W3	28,70 63.27	
	M30x2	22L	89	84,5	14	FF12-1-L2230 QRC-FF-12-F-22L-BT-W3	48,20 106.26	FF12-2-L2230 QRC-FF-12-M-22L-BP-W3	29,10 64.15	
	M24x1,5	16S	89	84,5	14	FF12-1-S1624 QRC-FF-12-F-16S-BT-W3	49,50 109.13	FF12-2-S1624 QRC-FF-12-M-16S-BP-W3	29,30 64.60	
	M30x2	20S	91	86,5	16	FF12-1-S2030 QRC-FF-12-F-20S-BT-W3	50,50 111.33	FF12-2-S2030 QRC-FF-12-M-20S-BP-W3	30,70 67.68	
	Male Thread with 24° Conical Bore - Bulkhead - Shape W according to DIN 3861									
		M18x1,5	12L	91	94	26	FF12-1-N1218 QRC-FF-12-F-12LB-BT-W3	42,40 93.48	FF12-2-N1218 QRC-FF-12-M-12LB-BP-W3	28 61.73
M22x1,5		15L	92	95	27	FF12-1-N1522 QRC-FF-12-F-15LB-BT-W3	44,20 97.44	FF12-2-N1522 QRC-FF-12-M-15LB-BP-W3	29,80 65.70	
M26x1,5		18L	92	95	27	FF12-1-N1826 QRC-FF-12-F-18LB-BT-W3	45,70 100.75	FF12-2-N1826 QRC-FF-12-M-18LB-BP-W3	31,30 69.00	
M30x2		22L	99	102,0	34	FF12-1-N2230 QRC-FF-12-F-22LB-BT-W3	48,70 107.37	FF12-2-N2230 QRC-FF-12-M-22LB-BP-W3	34,40 75.84	
M24x1,5		16S	94	97	29	FF12-1-T1624 QRC-FF-12-F-16SB-BT-W3	45,50 100.31	FF12-2-T1624 QRC-FF-12-M-16SB-BP-W3	31,60 69.67	
M30x2		20S	101	104	36	FF12-1-T2030 QRC-FF-12-F-20SB-BT-W3	51,50 113.54	FF12-2-T2030 QRC-FF-12-M-20SB-BP-W3	37,20 82.01	

Note: The connection of the two halves of a coupling is achieved depending on the type. It is important to observe the positive engagement of plug-type couplings and the secure tightening of screw-type couplings to the limit stop of the thread. Forced or improper separation will result in malfunction of the coupling.



FF/FU
FH

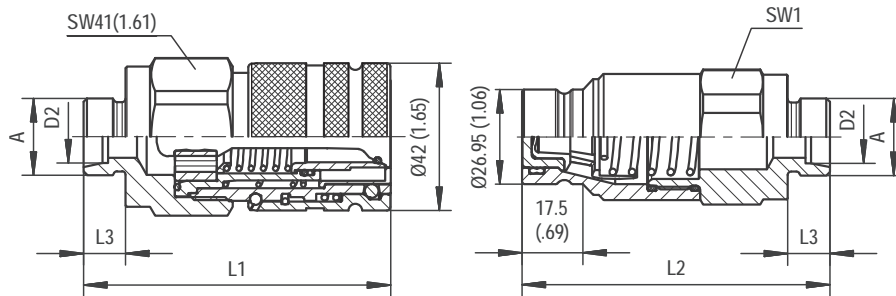

SW: Width across flats. All dimensions in mm (inch).

Series FF-16 ▪ BG 4A ▪ Nominal Size 16

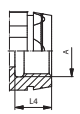
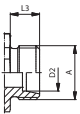
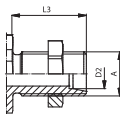
	Port A	Dimensions (mm/in)						Female Body	Weight	Male Tip	Weight
		ØD2	L1	L2	L3	L4	SW1	Old Part Numbers	(^{kg} /lbs) ca.	Old Part Numbers	(^{kg} /lbs) ca.
								STAUFF Ordering Codes	per 100	STAUFF Ordering Codes	per 100
Female Thread according to DIN 3852-2 - ANSI B 1.20.3 - SAE J1926-1											
	G 3/4"	87	73		16	36	FF16-1-IGF12	64,10	FF16-2-IGF12	29,20	
		3.43	2.87		.63	1.42	QRC-FF-16-F-G12-BT-W3	141.32	QRC-FF-16-M-G12-BP-W3	64.38	
	G 1"	89	80		18	41	FF16-1-IGF16	66,90	FF16-2-IGF16	28,50	
		3.50	3.15		.71	1.61	QRC-FF-16-F-G16-BT-W3	147.49	QRC-FF-16-M-G16-BP-W3	62.83	
	NPTF 3/4"-14	87	76			36	FF16-1-INF12	66,90	FF16-2-INF12	34,00	
	3.43	2.99			1.42	QRC-FF-16-F-NF12-BT-W3	147.49	QRC-FF-16-M-NF12-BP-W3	74.96		
	UN 1" 1/16-12	87	78		19	36	FF16-1-IUF12	65,10	FF16-2-IUF12	33,50	
		3.43	3.07		.75	1.42	QRC-FF-16-F-U12-BT-W3	143.52	QRC-FF-16-M-U12-BP-W3	73.86	
Male Thread with 24° Conical Bore - Shape W according to DIN 3861											
	M22x1,5	15L	87	88	12		36	FF16-1-L1522	60,80	FF16-2-L1522	36,60
			3.43	3.46	.47		1.42	QRC-FF-16-F-15L-BT-W3	134.04	QRC-FF-16-M-15L-BP-W3	80.69
	M26x1,5	18L	87	88	12		36	FF16-1-L1826	61,30	FF16-2-L1826	36,90
			3.43	3.46	.47		1.42	QRC-FF-16-F-18L-BT-W3	135.14	QRC-FF-16-M-18L-BP-W3	81.35
	M30x2	22L	89	90	14		36	FF16-1-L2230	61,80	FF16-2-L2230	37,30
			3.50	3.54	.55		1.42	QRC-FF-16-F-22L-BT-W3	136.25	QRC-FF-16-M-22L-BP-W3	82.23
	M24x1,5	16S	89	90	14		36	FF16-1-S1624	61,80	FF16-2-S1624	37,40
		3.50	3.54	.55		1.42	QRC-FF-16-F-16S-BT-W3	136.25	QRC-FF-16-M-16S-BP-W3	82.45	
	M30x2	20S	91	92	16		36	FF16-1-S2030	63,30	FF16-2-S2030	43,90
			3.58	3.62	.63		1.42	QRC-FF-16-F-20S-BT-W3	139.55	QRC-FF-16-M-20S-BP-W3	96.78
	M36x2	25S	93	94	18		41	FF16-1-S2536	65,60	FF16-2-S2536	47,20
			3.66	3.70	.71		1.61	QRC-FF-16-F-25S-BT-W3	144.62	QRC-FF-16-M-25S-BP-W3	104.06
Male Thread with 24° Conical Bore - Bulkhead - Shape W according to DIN 3861											
	M22x1,5	15L	102	103	27		36	FF16-1-N1522	63,60	FF16-2-N1522	39,50
			4.02	4.06	1.06		1.42	QRC-FF-16-F-15LB-BT-W3	140.21	QRC-FF-16-M-15LB-BP-W3	87.08
	M26x1,5	18L	102	103	27		36	FF16-1-N1826	65,10	FF16-2-N1826	41,10
			4.02	4.06	1.06		1.42	QRC-FF-16-F-18LB-BT-W3	143.52	QRC-FF-16-M-18LB-BP-W3	90.61
	M30x2	22L	109	110	34		36	FF16-1-N2230	68,10	FF16-2-N2230	43,90
			4.29	4.33	1.34		1.42	QRC-FF-16-F-22LB-BT-W3	150.14	QRC-FF-16-M-22LB-BP-W3	96.78
	M24x1,5	16S	104	105	29		36	FF16-1-T1624	65,40	FF16-2-T1624	41,40
		4.09	4.13	1.14		1.42	QRC-FF-16-F-16SB-BT-W3	144.18	QRC-FF-16-M-16SB-BP-W3	91.27	
	M30x2	20S	111	112	36		36	FF16-1-T2030	71,00	FF16-2-T2030	46,90
			4.37	4.41	1.42		1.42	QRC-FF-16-F-20SB-BT-W3	156.53	QRC-FF-16-M-20SB-BP-W3	103.40
	M36x2	25S	113	114	38		41	FF16-1-T2536	76,20	FF16-2-T2536	58,20
			4.45	4.49	1.50		1.61	QRC-FF-16-F-25SB-BT-W3	167.99	QRC-FF-16-M-25SB-BP-W3	128.31

Note: The connection of the two halves of a coupling is achieved depending on the type. It is important to observe the positive engagement of plug-type couplings and the secure tightening of screw-type couplings to the limit stop of the thread. Forced or improper separation will result in malfunction of the coupling.



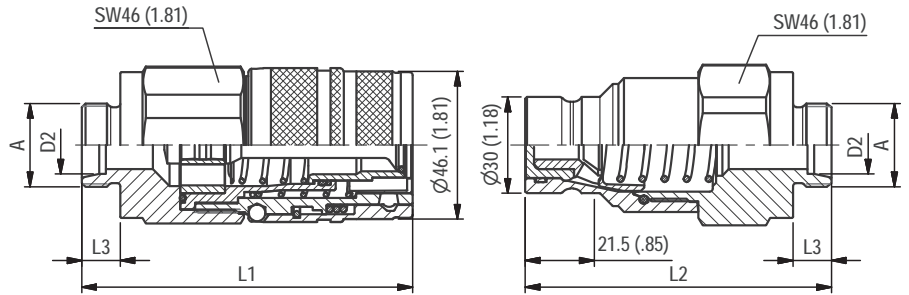

SW: Width across flats. All dimensions in mm (inch).

Series FF-19 • BG 4 • Nominal Size 19

Port A	Dimensions (mm/in)					Female Body	Weight	Male Tip	Weight
	ØD2	L1	L2	L3	L4	Old Part Numbers STAUFF Ordering Codes	(^{kg} /lbs) ca. per 100	Old Part Numbers STAUFF Ordering Codes	(^{kg} /lbs) ca. per 100
Female Thread according to DIN 3852-2 - ISO 6149-1 - ANSI B 1.20.3- SAE J1926-1									
	G 3/4"	99	84		16	FF19-1-IGF12	92,90	FF19-2-IGF12	53,10
		3.89	3.31		.63	QRC-FF-19-F-G12-BT-W3	204.81	QRC-FF-19-M-G12-BP-W3	117.07
	G 1"	99	84		18	FF19-1-IGF16	87,50	FF19-2-IGF16	47,40
		3.89	3.31		.71	QRC-FF-19-F-G16-BT-W3	192.90	QRC-FF-19-M-G16-BP-W3	104.50
	NPTF 3/4"-14	99	84			FF19-1-INF12	94,40	FF19-2-INF12	54,40
		3.90	3.31			QRC-FF-19-F-NF12-BT-W3	208.12	QRC-FF-19-M-NF12-BP-W3	119.93
	NPTF 1"-11 1/2	99	84			FF19-1-INF16	90,50	FF19-2-INF16	50,50
		3.90	3.31			QRC-FF-19-F-NF16-BT-W3	199.52	QRC-FF-19-M-NF16-BP-W3	111.33
	UN 1" 1/16-12	99	84		19	FF19-1-IUF12	93,10	FF19-2-IUF12	53
		3.90	3.31		.75	QRC-FF-19-F-U12-BT-W3	205.25	QRC-FF-19-M-U12-BP-W3	116.85
	UN 1" 5/16-12	99	84		19	FF19-1-IUF16	89,30	FF19-2-IUF16	47,90
		3.90	3.31		.75	QRC-FF-19-F-U16-BT-W3	196.87	QRC-FF-19-M-U16-BP-W3	105.60
Male Thread with 24° Conical Bore - Shape W according to DIN 3861									
	M26x1,5	18L	103	96	12	FF19-1-L1826	91,10	FF19-2-L1826	60,70
		4.06	3.76	.47		QRC-FF-19-F-18L-BT-W3	200.84	QRC-FF-19-M-18L-BP-W3	133.82
	M30x2	22L	105	98	14	FF19-1-L2230	91,10	FF19-2-L2230	59,80
		4.14	3.84	.55		QRC-FF-19-F-22L-BT-W3	200.84	QRC-FF-19-M-22L-BP-W3	131.84
	M36x2	28L	105	98	14	FF19-1-L2836	90,30	FF19-2-L2836	58,10
		4.14	3.84	.55		QRC-FF-19-F-28L-BT-W3	199.08	QRC-FF-19-M-28L-BP-W3	128.09
	M30x2	20S	107	100	16	FF19-1-S2030	93,10	FF19-2-S2030	62,50
		4.22	3.92	.63		QRC-FF-19-F-20S-BT-W3	205.25	QRC-FF-19-M-20S-BP-W3	137.79
	M36x2	25S	109	102	18	FF19-1-S2536	94,70	FF19-2-S2536	63,20
		4.30	4.00	.71		QRC-FF-19-F-25S-BT-W3	208.78	QRC-FF-19-M-25S-BP-W3	139.33
	M42x2	30S	111	104	20	FF19-1-S3042	96,10	FF19-2-S3042	63,70
		4.38	4.07	.79		QRC-FF-19-F-30S-BT-W3	211.86	QRC-FF-19-M-30S-BP-W3	140.43
Male Thread with 24° Conical Bore - Bulkhead - Shape W according to DIN 3861									
	M26x1,5	18L	125	118	34	FF19-1-N1826	97,20	FF19-2-N1826	66,80
		4.93	4.63	1.34		QRC-FF-19-F-18LB-BT-W3	214.29	QRC-FF-19-M-18LB-BP-W3	147.27
	M30x2	22L	125	118	34	FF19-1-N2230	97,70	FF19-2-N2230	66,50
		4.93	4.63	1.34		QRC-FF-19-F-22LB-BT-W3	215.39	QRC-FF-19-M-22LB-BP-W3	146.61
	M36x2	28L	125	118	34	FF19-1-N2836	99,20	FF19-2-N2836	67
		4.93	4.63	1.34		QRC-FF-19-F-28LB-BT-W3	218.70	QRC-FF-19-M-28LB-BP-W3	147.71
	M30x2	20S	129	120	36	FF19-1-T2030	101,80	FF19-2-T2030	70,40
		5.09	4.70	1.42		QRC-FF-19-F-20SB-BT-W3	224.43	QRC-FF-19-M-20SB-BP-W3	155.21
	M36x2	25S	129	124	38	FF19-1-T2536	105,76	FF19-2-T2536	74,30
		5.09	4.86	1.50		QRC-FF-19-F-25SB-BT-W3	233.16	QRC-FF-19-M-25SB-BP-W3	163.80
	M42x2	30S	131	124	38	FF19-1-T3042	110,10	FF19-2-T3042	77,80
		5.17	4.86	1.50		QRC-FF-19-F-30SB-BT-W3	242.73	QRC-FF-19-M-30SB-BP-W3	171.52

Note: The connection of the two halves of a coupling is achieved depending on the type. It is important to observe the positive engagement of plug-type couplings and the secure tightening of screw-type couplings to the limit stop of the thread. Forced or improper separation will result in malfunction of the coupling.



FF/FU
FH

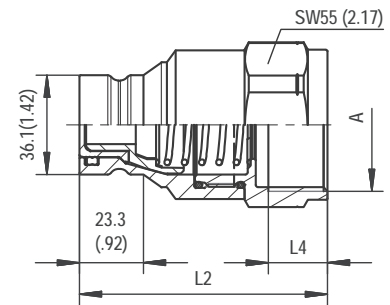
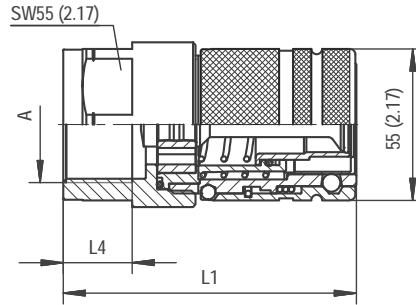

SW: Width across flats. All dimensions in mm (inch).

Series FF-25 ▪ BG 5 ▪ Nominal Size 25

	Port A	Dimensions (^{mm} / _{in})				Female Body	Weight	Male Tip	Weight	
		ØD2	L1	L2	L3	L4	Old Part Numbers	(^{kg} / _{lbs}) ca.	Old Part Numbers	(^{kg} / _{lbs}) ca.
							STAUFF Ordering Codes	per 100	STAUFF Ordering Codes	per 100
Female Thread according to DIN 3852-2 - ANSI B 1.20.3 - SAE J1926-1										
	G 1"	106	90		18	FF25-1-IGF16	141,50	FF25-2-IGF16	81,50	
		4.17	3.54		.71	QRC-FF-25-F-G16-BT-W3	311,95	QRC-FF-25-M-G16-BP-W3	179,68	
	G 1" 1/4	106	90		20	FF25-1-IGF20	130,10	FF25-2-IGF20	71,40	
		4.17	3.54		.79	QRC-FF-25-F-G20-BT-W3	286,82	QRC-FF-25-M-G20-BP-W3	157,41	
	G 1" 1/2	106	95,6		22	FF25-1-IGF24	120,50	FF25-2-IGF24	83,00	
		4.17	3.76		.87	QRC-FF-25-F-G24-BT-W3	265,66	QRC-FF-25-M-G24-BP-W3	182,98	
	NPTF 1" 11 1/2	106	90			FF25-1-INF16	143,00	FF25-2-INF16	83,00	
		4.17	3.54			QRC-FF-25-F-NF16-BT-W3	315,26	QRC-FF-25-M-NF16-BP-W3	182,98	
	NPTF 1" 1/4-11 1/2	106	90			FF25-1-INF20	133,70	FF25-2-INF20	73,60	
		4.17	3.54			QRC-FF-25-F-NF20-BT-W3	294,76	QRC-FF-25-M-NF20-BP-W3	162,26	
	UN 1" 5/16 - 12	106	90		19	FF25-1-IUF16	140,50	FF25-2-IUF16	80,80	
		4.17	3.54		.75	QRC-FF-25-F-U16-BT-W3	309,75	QRC-FF-25-M-U16-BP-W3	178,13	
	UN 1" 5/8 - 12	106	90		19	FF25-1-IUF20	132,10	FF25-2-IUF20	72,00	
		4.17	3.54		.75	QRC-FF-25-F-U20-BT-W3	291,23	QRC-FF-25-M-U20-BP-W3	158,73	

Note: The connection of the two halves of a coupling is achieved depending on the type. It is important to observe the positive engagement of plug-type couplings and the secure tightening of screw-type couplings to the limit stop of the thread. Forced or improper separation will result in malfunction of the coupling.



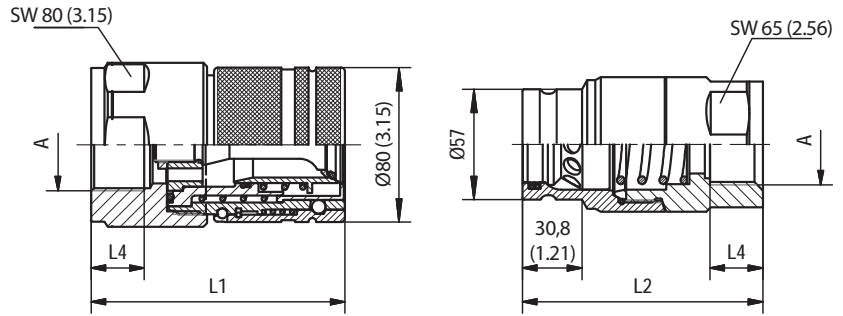

SW: Width across flats. All dimensions in mm (inch).

Series FF-38 • BG 6 • Nominal Size 38

Port A	Dimensions (^{mm} / _{in})				Female Body		Weight	Male Tip		Weight
	ØD2	L1	L2	L3	L4	Old Part Numbers	(^{kg} / _{lbs}) ca.	Old Part Numbers	(^{kg} / _{lbs}) ca.	
Female Thread according to ISO 3852-2 - ANSI B 1.20.3 - SAE J1926-1						STAUFF Ordering Codes	per 100	STAUFF Ordering Codes	per 100	
	G 1 1/4"	131,6	124,6		21,5	FF38-1-IGF20	388,40	FF38-2-IGF20	218,60	
		5.18	4.91		.85	QRC-FF-38-F-G20-S1-W3	856.28	QRC-FF-38-M-G20-BT-W3	481.93	
	G 1 1/2"	131,6	124,6		23	FF38-1-IGF24	379,10	FF38-2-IGF24	209,90	
		5.18	4.91		.89	QRC-FF-38-F-G24-S1-W3	835.77	QRC-FF-38-M-G24-BT-W3	462.75	
	NPTF 1" 1/4- 11 1/2	131,6	124,6			FF38-1-INF20	390,50	FF38-2-INF20	221,10	
		5.18	4.91			QRC-FF-38-F-NF20-S1-W3	860.91	QRC-FF-38-M-NF20-BT-W3	487.44	
	NPTF 1" 1/2- 11 1/2	131,6	124,6			FF38-1-INF24	381,20	FF38-2-INF24	216,80	
		5.18	4.91			QRC-FF-38-F-NF24-S1-W3	840.40	QRC-FF-38-M-NF24-BT-W3	477.96	
	UN 1" 5/8-12	131,6	124,6		19	FF38-1-IUF20	387,70	FF38-2-IUF20	218,50	
		5.18	4.91		.75	QRC-FF-38-F-U20-S1-W3	854.73	QRC-FF-38-M-U20-BT-W3	481.71	
	UN 1" 7/8-12	131,6	124,6		19	FF38-1-IUF24	376,10	FF38-2-IUF24	210,30	
		5.18	4.91		.75	QRC-FF-38-F-U24-S1-W3	829.16	QRC-FF-38-M-U24-BT-W3	463.63	

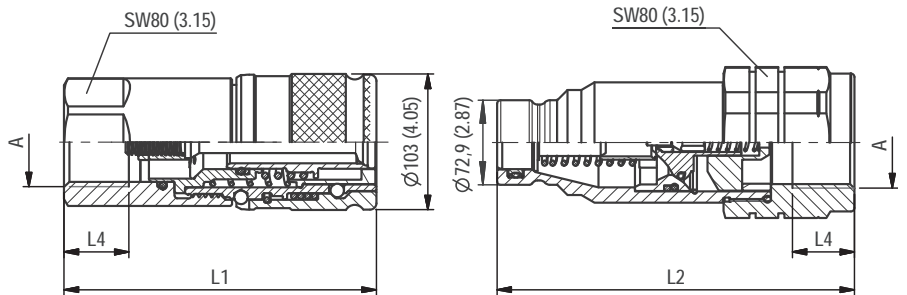

SW: Width across flats. All dimensions in mm (inch).

Series FH/FU 51 • BG 7 • Nominal Size 51

Port A	Dimensions (^{mm} / _{in})				Female Body		Weight	Male Tip		Weight
	ØD2	L1	L2	L3	L4	Old Part Numbers	(^{kg} / _{lbs}) ca.	Old Part Numbers	(^{kg} / _{lbs}) ca.	
Female Thread according to DIN 3852-2-A - ANSI B 1.20.3						STAUFF Ordering Codes	per 100	STAUFF Ordering Codes	per 100	
	G 2"	147,4	173		24	FH51-1-IGF32	550	FU51-2-IGF32	489	
		5.80	6.81		.94	QRC-FH-51-F-G32-BT-W66	1212.54	QRC-FU-51-M-G32-BT-W66	1078.06	
	NPTF 2" -11 1/2	147,4	173			FH51-1-INF32	540	FU51-2-INF32	479	
		5.80	6.81			QRC-FH-51-F-NF32-BT-W66	1190.50	QRC-FU-51-M-NF32-BT-W66	1056.01	

Note: The connection of the two halves of a coupling is achieved depending on the type. It is important to observe the positive engagement of plug-type couplings and the secure tightening of screw-type couplings to the limit stop of the thread. Forced or improper separation will result in malfunction of the coupling.



FF/FU
FH

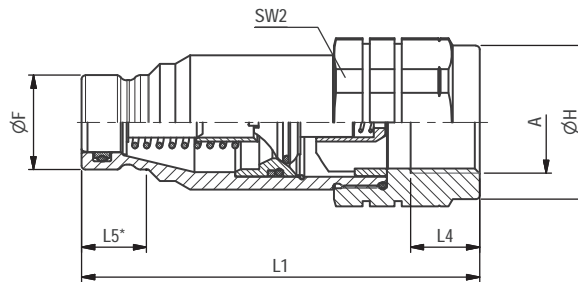

SW: Width across flats. All dimensions in mm (inch). Drawing similar Series FU-12.
* Insertion Male Tip

Series FU-10 • BG 2 • Nominal Size 10 • Connect Under Pressure

Port A	Dimensions (mm/in)						Male Tip		Weight (kg/lbs) ca. per 100
	ØF	ØH	L1	L4	L5	SW2	Old Part Numbers	STAUFF Ordering Codes	
Female Thread according to DIN 3852-2									
	G 3/8"	19,79	29,3	87	12	15,6	30	FU10-2-IGF06	24,10
		.78	1.17	3.43	.47	.61	1.18	QRC-FU-10-M-G06-BT-W3	53.13
	G 1/2"	19,79	29,3	90	14	15,6	30	FU10-2-IGF08	24,60
		.78	1.17	3.54	.55	.61	1.18	QRC-FU-10-M-G08-BT-W3	54.23

Series FU-12 • BG 3 • Nominal Size 12,5 • Connect Under Pressure

Port A	Dimensions (mm/in)						Male Tip		Weight (kg/lbs) ca. per 100
	ØF	ØH	L1	L4	L5	SW2	Old Part Numbers	STAUFF Ordering Codes	
Female Thread according to DIN 3852-2									
	G 1/2"	24,58	40	98	14	16,9	41	FU12-2-IGF08	49,20
		.97	1.57	3.86	.55	.67	1.61	QRC-FU-12-M-G08-BT-W3	108.47
	G 3/4"	24,58	40	104	16	16,9	41	FU12-2-IGF12	51,10
		.97	1.57	4.09	.63	.67	1.61	QRC-FU-12-M-G12-BT-W3	112.66

Series FU-19 • BG 4 • Nominal Size 19 • Connect Under Pressure

Port A	Dimensions (mm/in)						Male Tip		Weight (kg/lbs) ca. per 100
	ØF	ØH	L1	L4	L5	SW2	Old Part Numbers	STAUFF Ordering Codes	
Female Thread according to DIN 3852-2									
	G 3/4"	30	45,5	114	16	21,5	46	FU19-2-IGF12	82,60
		1.18	1.79	4.49	.63	.85	1.81	QRC-FU-19-M-G12-BT-W3	182.10
	G 1"	30	45,5	114	18	21,5	46	FU19-2-IGF16	77,90
		1.18	1.79	4.49	.71	.85	1.81	QRC-FU-19-M-G16-BT-W3	171.74

Note: The connection of the two halves of a coupling is achieved depending on the type. It is important to observe the positive engagement of plug-type couplings and the secure tightening of screw-type couplings to the limit stop of the thread. Forced or improper separation will result in malfunction of the coupling.

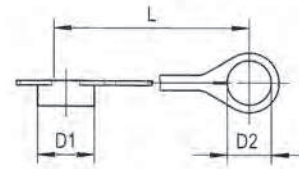
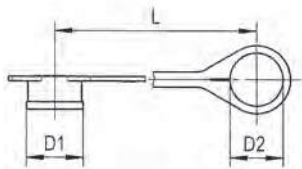

Series FH/FU/FF • Dust Protection

FF/FU
FH

Dimensions (mm/in)			Material	Dust Cap for Male Tip	
D1	D2	L		Old Part Numbers	STAUFF Ordering Codes
28	24	170	Plastic (Colour: Red)	FF06-0-RT001	QRC-FF-06-DM-24-K-RD
1.10	.94	6.69			
32	27	115	Plastic (Colour: Red)	FF10-0-RT001	QRC-FF-10-DM-27-K-RD
1.26	1.06	4.53			
38	35,5	135	Plastic (Colour: Red)	FF12-0-RT001	QRC-FF-12-DM-36-K-RD
1.50	1.40	5.31			
42	30	220	Plastic (Colour: Red)	FF16-0-RT001	QRC-FF-16-DM-30-K-RD
1.65	1.18	8.66			
48	45,5	150	Plastic (Colour: Red)	FF19-0-RT001	QRC-FF-19-DM-46-K-RD
1.89	1.79	5.91			
46	51	290	Plastic (Colour: Red)	FF25-0-RT001	QRC-FF-25-DM-51-K-RD
1.81	2.01	11.42			

Dimensions (mm/in)			Material	Dust Plug for Female Body	
D1	D2	L		Old Part Numbers	STAUFF Ordering Codes
34	24	170	Plastic (Colour: Red)	FF06-9-RT001	QRC-FF-06-DF-24-K-RD
1.34	.94	6.69			
38	30	130	Plastic (Colour: Red)	FF10-9-RT001	QRC-FF-10-DF-30-K-RD
1.50	1.18	5.12			
45	35,5	140	Plastic (Colour: Red)	FF12-9-RT001	QRC-FF-12-DF-36-K-RD
1.77	1.40	5.51			
46	30	225	Plastic (Colour: Red)	FF16-9-RT001	QRC-FF-16-DF-30-K-RD
1.81	1.18	8.86			
62	45,5	170	Plastic (Colour: Red)	FF19-9-RT001	QRC-FF-19-DF-46-K-RD
2.44	1.79	6.69			
62	51	290	Plastic (Colour: Red)	FF25-9-RT001	QRC-FF-25-DF-51-K-RD
2.44	2.01	11.42			

In addition to the standard colours as stated above, plastic dust caps are also available in blue, green, yellow and black. Please use the old color codes BL, GN, GE and SW respectively instead of RT. Please use the STAUFF codes BU, GN, YE and BK respectively instead of RD.



FF/FU
FH

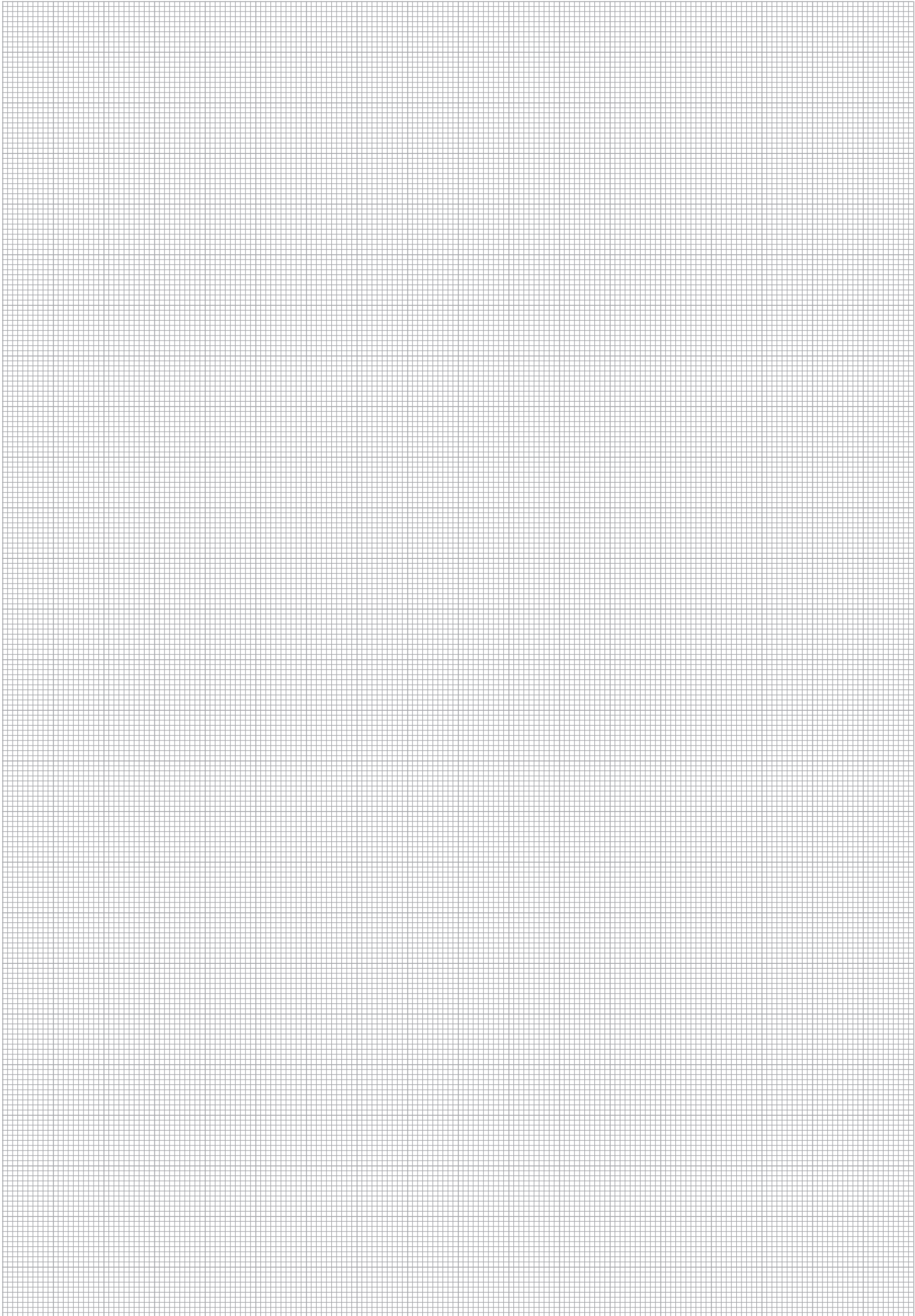

Series FH ▪ Stainless Steel

Series FH ▪ Overview	34
Series FH-10 ▪ BG 2 ▪ Nominal Size 10	35
Series FH-12 ▪ BG 3 ▪ Nominal Size 12,5	35
Series FH-19 ▪ BG 6 ▪ Nominal Size 19	36

FF/FU
FH



Series FH • Stainless Steel

Material	Stainless Steel V4A (AISI 316L)
Surface Finishing	-
Standard Seal Material(s)	FKM (Viton®), PTFE ²
Working Temperature	-25° C ... +200° C / -13° F ... +392° F
Valve Design	Flat Face
Connection	Push
Disconnection	Actuate Push Sleeve
Connect Under Pressure	not allowed
Application	Industrial Hydraulic
ISO Interchange	ISO 16028



²Alternative seal materials are available on request.

Technical Data

Series	BG	DN Zoll	DN metric ISO 4397	Q _{max}		Working Pressure		Bursting Pressure Connected		Female Body		Male Tip		Spillage	
				l/min	US GPM	bar	PSI	bar	PSI	bar	PSI	bar	PSI	ml	fl oz
FH-10	2	3/8"	10	80	21.13	250	3626	1300	18855	750	10878	1000	14504	0,015	.0005
FH-12	3	1/2"	12,5	120	31.70	250	3626	1300	18855	750	10878	1000	14504	0,02	.0007
FH-19	6	3/4"	19	180	47.55	250	3626	1300	18855	750	10878	1000	14504	0,032	.0011

The indicated pressure ratings only apply to the coupling itself and depend on the connection type.

Flow Characteristics

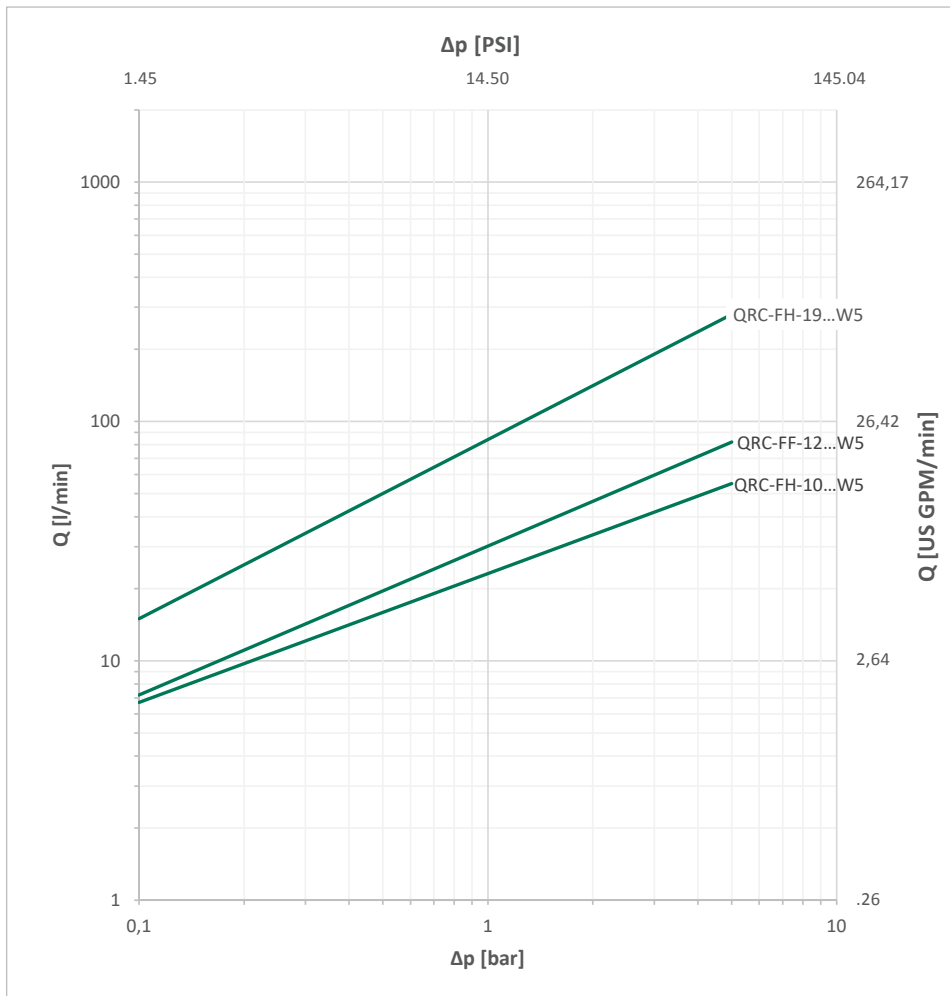

Please note: Unless otherwise stated, all flow characteristics have been determined with hydraulic oil with a kinematic viscosity of 28,8 - 35,2 mm²/s (28,8 - 35,2 cSt) and are only valid for components with non-reducing connections.



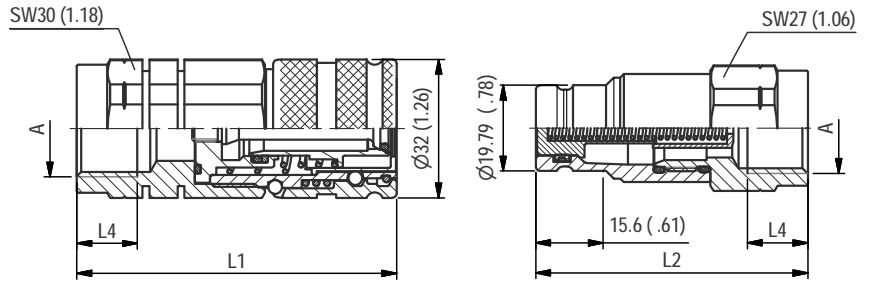

SW: Width across flats. All dimensions in mm (inch).

Series FH-10 • BG 2 • Nominal Size 10

Port A	Dimensions (mm/in)					Female Body Old Part Numbers STAUFF Ordering Codes	Weight (kg/lbs) ca. per 100	Male Tip Old Part Numbers STAUFF Ordering Codes	Weight (kg/lbs) ca. per 100
	ØD2	L1	L2	L3	L4				
Female Thread according to DIN 3852-2 - ISO 9974-1 - ANSI B 1.20.3									
	G 3/8"	68,9	57,8		12,5	FH10-1-IGF06VA QRC-FH-10-F-G06-VT-W5	30 66.14	FH10-2-IGF06VA QRC-FH-10-M-G06-VT-W5	15,80 34.83
	G 1/2"		2.71	2.28		.49			
			74	62,9		14	FH10-1-IGF08VA QRC-FH-10-F-G08-VT-W5	30,40 67.02	FH10-2-IGF08VA QRC-FH-10-M-G08-VT-W5
NPTF 1/2"		74	62,9			FH10-1-INF08VA QRC-FH-10-F-NF08-VT-W5	30,80 67.90	FH10-2-INF08VA QRC-FH-10-M-NF08-VT-W5	15,20 33.51
Male Thread with 24° Conical Bore - Shape W according to DIN 3861									
	M18x1,5	12L	88,3	79,4	11	FH10-1-L1218VA QRC-FH-10-F-12L-VT-W5	34,50 76.06	FH10-2-L1218VA QRC-FH-10-M-12L-VT-W5	20,40 44.97
			3.48	3.13	.43				
	M22x1,5	15L		110,9	27	FH10-1-N1522VA QRC-FH-10-F-15LB-VT-W5		FH10-2-N1522VA QRC-FH-10-M-15LB-VT-W5	29,80 65.70
			4.37	1.06					

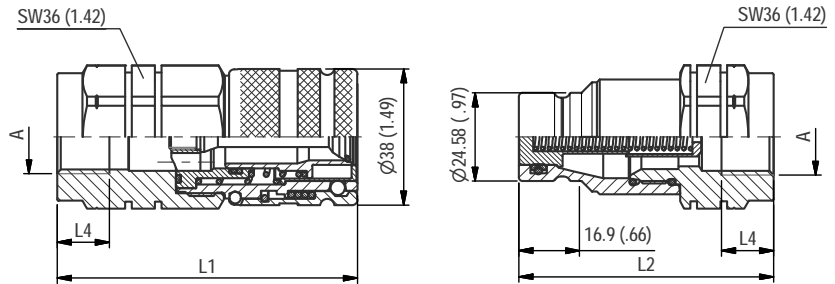

SW: Width across flats. All dimensions in mm (inch).

Series FH-12 • BG 3 • Nominal Size 12,5

Port A	Dimensions (mm/in)					Female Body Old Part Numbers STAUFF Ordering Codes	Weight (kg/lbs) ca. per 100	Male Tip Old Part Numbers STAUFF Ordering Codes	Weight (kg/lbs) ca. per 100
	ØD2	L1	L2	L3	L4				
Female Thread according to DIN 3852-2 - ISO 9974-1 - ANSI B 1.20.3									
	G 1/2"	84	71		14	FH12-1-IGF08VA QRC-FH-12-F-G08-VT-W5	52,50 115.74	FH12-2-IGF08VA QRC-FH-12-M-G08-VT-W5	32,60 71.87
			3.31	2.80		.55			
	G 3/4"		84	71		16	FH12-1-IGF12VA QRC-FH-12-F-G12-VT-W5	49,10 108.25	FH12-2-IGF12VA QRC-FH-12-M-G12-VT-W5
NPTF 1/2"		84	71			FH12-1-INF08VA QRC-FH-12-F-NF08-VT-W5	52,80 116.40	FH12-2-INF08VA QRC-FH-12-M-NF08-VT-W5	33 72.75
		3.31	2.80						
Male Thread with 24° Conical Bore - Shape W according to DIN 3861									
	M18x1,5	12L	103,8	91,1	11	FH12-1-L1218VA QRC-FH-12-F-12L-VT-W5	60,10 132.50	FH12-2-L1218VA QRC-FH-12-M-12L-VT-W5	40,40 89.07
			4.09	3.59	.43				
	M22x1,5	15L		104,8	92,1	12	FH12-1-L1522VA QRC-FH-12-F-15L-VT-W5	60,60 133.60	FH12-2-L1522VA QRC-FH-12-M-15L-VT-W5
			4.13	3.63	1.06				

Note: The connection of the two halves of a coupling is achieved depending on the type. It is important to observe the positive engagement of plug-type couplings and the secure tightening of screw-type couplings to the limit stop of the thread. Forced or improper separation will result in malfunction of the coupling.



FF/FU
FH

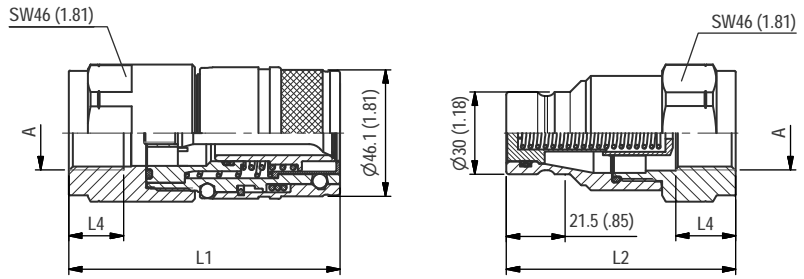

SW: Width across flats. All dimensions in mm (inch).

Series FH-19 • BG 6 • Nominal Size 19

Port A	Dimensions (mm/in)					Female Body	Weight	Male Tip	Weight	
	ØD2	L1	L2	L3	L4	Old Part Numbers STAUFF Ordering Codes	(kg/lbs) ca. per 100	Old Part Numbers STAUFF Ordering Codes	(kg/lbs) ca. per 100	
Female Thread according to DIN 3852-2 - ISO 9974-1 - ANSI B 1.20.3										
	G 3/4"	99	84		16	FH19-1-IGF12VA	102,90	FH19-2-IGF12VA	57	
		3.90	3.31		.63	QRC-FH-19-F-G12-VT-W5	226.86	QRC-FH-19-M-G12-VT-W5	125.66	
	G 1"	99	84		18	FH19-1-IGF16VA	97,20	FH19-2-IGF16VA	51,10	
		3.90	3.31		.71	QRC-FH-19-F-G16-VT-W5	214.29	QRC-FH-19-M-G16-VT-W5	112.66	
	NPTF 1"-11 1/2	99	84			FH19-1-INF16VA	100,40	FH19-2-INF16VA	54,30	
		3.90	3.31			QRC-FH-19-F-NF16-VT-W5	221.34	QRC-FH-19-M-NF16-VT-W5	119.71	
Male Thread with 24° Conical Bore - Shape W according to DIN 3861										
	M30x2	20S	130	114,8	16		FH19-1-S2030VA	120	FH19-2-S2030VA	74,10
			5.12	4.52	.63		QRC-FH-19-F-20S-VT-W5	264.55	QRC-FH-19-M-20S-VT-W5	163.36

Note: The connection of the two halves of a coupling is achieved depending on the type. It is important to observe the positive engagement of plug-type couplings and the secure tightening of screw-type couplings to the limit stop of the thread. Forced or improper separation will result in malfunction of the coupling.



Series F0 ▪ Stainless Steel

Series F0 ▪ Overview	38
Series F0-06 ▪ BG 1 ▪ Nominal Size 6,3	39
Series F0-10 ▪ BG 2 ▪ Nominal Size 10	39
Series F0-12 ▪ BG 3 ▪ Nominal Size 12,5	39
Series F0-19 ▪ BG 6 ▪ Nominal Size 19	39
Series F0-25 ▪ BG 8 ▪ Nominal Size 25	40

F0



Series FO • Stainless Steel

Material	Stainless Steel V4A (AISI 316)
Surface Finishing	-
Standard Seal Material(s)	FKM (Viton®) ²
Working Temperature	-25° C ... +200° C / -13° F ... +392° F
Valve Design	Flat Face
Connection	Push
Disconnection	Actuate Push Sleeve
Connect Under Pressure	not allowed
Application	Offshore
ISO Interchange	-



FO

² Alternative seal materials are available on request.

Technical Data

Series	BG	DN Zoll Inch	DN metric ISO 4397	Q _{max}		Working Pressure		Bursting Pressure Connected		Female Body		Male Tip		Spillage	
				l/min	US GPM	bar	PSI	bar	PSI	bar	PSI	bar	PSI	ml	fl oz
FO-06	1	1/4"	6,3	20	5.28	350	5076	2150	31183	1700	24656	1970	28572	0,01	.0003
FO-10	2	3/8"	10	45	11.89	350	5076	2000	29008	1300	18855	1400	20305	0,02	.0007
FO-12	3	1/2"	12,5	60	15.85	350	5076	2000	29008	1300	18855	1100	15954	0,03	.0010
FO-19	6	3/4"	19 (20)	150	39.62	350	5076	1700	24656	1280	18565	1100	15954	0,06	.0020
FO-25	8	1"	25	240	63.40	350	5076	1450	21030	1150	16679	1000	14504	0,1	.0034

The indicated pressure ratings only apply to the coupling itself and depend on the connection type.

Flow Characteristics

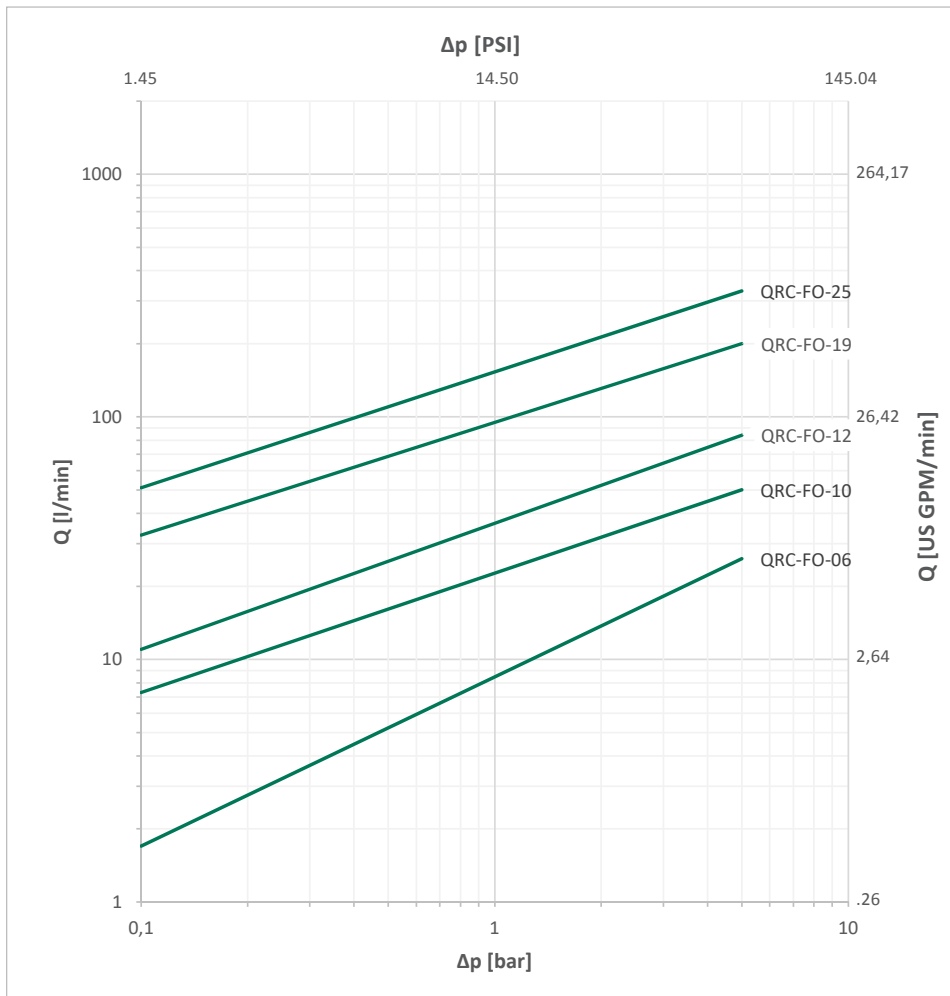

Please note: Unless otherwise stated, all flow characteristics have been determined with hydraulic oil with a kinematic viscosity of 28,8 - 35,2 mm²/s (28,8 - 35,2 cSt) and are only valid for components with non-reducing connections.



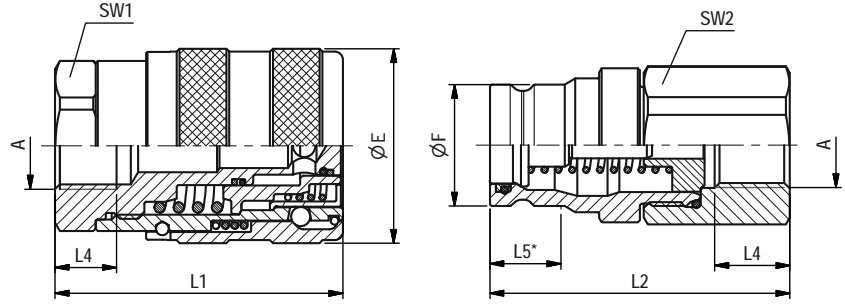

SW: Width across flats. All dimensions in mm (inch). Drawing similar Series FO-12.
* Insertion Male Tip

Series FO-06 ▪ BG 1 ▪ Nominal Size 6,3

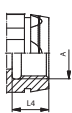
Port A	Dimensions (^{mm} / _{in})								Female Body		Weight (^{kg} / _{lbs}) ca. per 100	Male Tip		Weight (^{kg} / _{lbs}) ca. per 100
	ØE	ØF	L1	L2	L4 min	L5	SW1	SW2	Old Part Numbers	STAUFF Ordering Codes		Old Part Numbers	STAUFF Ordering Codes	
Female Thread according to DIN 3852 - ANSI B 1.20.3														
	G 1/4"	30	18	52	61,5	12	13,5	24	22	FO06-1-IGF04-VA	17,90	FO06-2-IGF04-VA	12,20	
		1.18	.71	2.04	2.42	.47	.53	.94	.87	QRC-FO-06-F-G04-VT-W5	39.46	QRC-FO-06-M-G04-VT-W5	26.90	
	NPTF 1/4" -18	30	18	52	61,5	12	13,5	24	22	FO06-1-INF04-VA	18	FO06-2-INF04-VA	12,30	
		1.18	.71	2.04	2.42	.47	.53	.94	.87	QRC-FO-06-F-NF04-VT-W5	39.68	QRC-FO-06-M-NF04-VT-W5	27.12	

Series FO-10 ▪ BG 2 ▪ Nominal Size 10

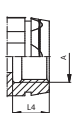
Port A	Dimensions (^{mm} / _{in})								Female Body		Weight (^{kg} / _{lbs}) ca. per 100	Male Tip		Weight (^{kg} / _{lbs}) ca. per 100
	ØE	ØF	L1	L2	L4 min	L5	SW1	SW2	Old Part Numbers	STAUFF Ordering Codes		Old Part Numbers	STAUFF Ordering Codes	
Female Thread according to DIN 3852 - ANSI B 1.20.3														
	G 3/8"	40	23,7	62	70	14	16,5	30	30	FO10-1-IGF06-VA	39	FO10-2-IGF06-VA	21,70	
		1.57	.93	2.44	2.76	.47	.65	1.18	1.18	QRC-FO-10-F-G06-VT-W5	85.98	QRC-FO-10-M-G06-VT-W5	47.84	
	NPTF 3/8" -18	40	23,7	62	70		16,5	30	30	FO10-1-INF06-VA	39	FO10-2-INF06-VA	22	
		1.57	.93	2.44	2.76		.65	1.18	1.18	QRC-FO-10-F-NF06-VT-W5	85.98	QRC-FO-10-M-NF06-VT-W5	48.50	
	G 1/2"	40	23,7	62	69,5	14	16,5	30	30	FO10-1-IGF08-VA	36,90	FO10-2-IGF08-VA	20,10	
		1.57	.93	2.44	2.74	.55	.65	1.18	1.18	QRC-FO-10-F-G08-VT-W5	81.35	QRC-FO-10-M-G08-VT-W5	44.31	
NPTF 1/2" -14	40	23,7	62	73,5		16,5	30	30	FO10-1-INF08-VA	37,10	FO10-2-INF08-VA	21,60		
	1.57	.93	2.44	2.89		.65	1.18	1.18	QRC-FO-10-F-NF08-VT-W5	81.79	QRC-FO-10-M-NF08-VT-W5	47.62		

Series FO-12 ▪ BG 3 ▪ Nominal Size 12,5

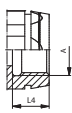
Port A	Dimensions (^{mm} / _{in})								Female Body		Weight (^{kg} / _{lbs}) ca. per 100	Male Tip		Weight (^{kg} / _{lbs}) ca. per 100
	ØE	ØF	L1	L2	L4 min	L5	SW1	SW2	Old Part Numbers	STAUFF Ordering Codes		Old Part Numbers	STAUFF Ordering Codes	
Female Thread according to DIN 3852 - ANSI B 1.20.3														
	G 1/2"	48	30	71	74	14	17,5	38	36	FO12-1-IGF08-VA	63,10	FO12-2-IGF08-VA	38,30	
		1.89	1.18	2.80	2.91	.55	.69	1.49	1.42	QRC-FO-12-F-G08-VT-W5	139.11	QRC-FO-12-M-G08-VT-W5	84.44	
	NPTF 1/2" -14	48	30	71	74		17,5	38	36	FO12-1-INF08-VA	63,40	FO12-2-INF08-VA	38,50	
		1.89	1.18	2.80	2.91		.69	1.49	1.42	QRC-FO-12-F-NF08-VT-W5	139.77	QRC-FO-12-M-NF08-VT-W5	84.88	

Series FO-19 ▪ BG 6 ▪ Nominal Size 19

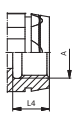
Port A	Dimensions (^{mm} / _{in})								Female Body		Weight (^{kg} / _{lbs}) ca. per 100	Male Tip		Weight (^{kg} / _{lbs}) ca. per 100
	ØE	ØF	L1	L2	L4 min	L5	SW1	SW2	Old Part Numbers	STAUFF Ordering Codes		Old Part Numbers	STAUFF Ordering Codes	
Female Thread according to DIN 3852 - ANSI B 1.20.3														
	G 3/4"	58	38,6	79	90	16	22	46	41	FO19-1-IGF12-VA	95,40	FO19-2-IGF12-VA	56	
		2.28	1.52	3.11	3.54	.63	.87	1.81	1.61	QRC-FO-19-F-G12-VT-W5	210.32	QRC-FO-19-M-G12-VT-W5	123.46	
	NPTF 3/4" -14	58	38,6	79	90		22	46	41	FO19-1-INF12-VA	96	FO19-2-INF12-VA	56,70	
		2.28	1.52	3.11	3.54		.87	1.81	1.61	QRC-FO-19-F-NF12-VT-W5	211.64	QRC-FO-19-M-NF12-VT-W5	125.00	

Note: The connection of the two halves of a coupling is achieved depending on the type. It is important to observe the positive engagement of plug-type couplings and the secure tightening of screw-type couplings to the limit stop of the thread. Forced or improper separation will result in malfunction of the coupling.



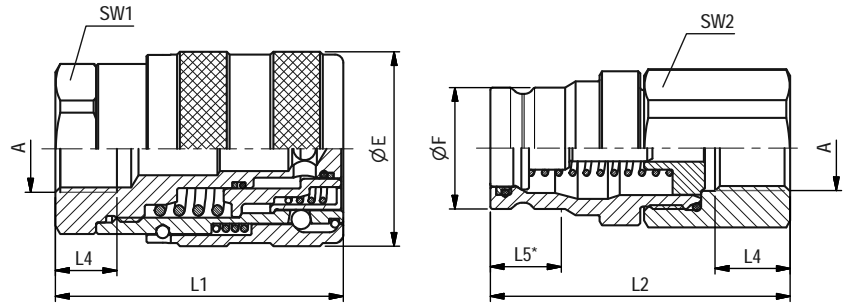

SW: Width across flats. All dimensions in mm (inch). Drawing similar Series F0-12.
* Insertion Male Tip

Series F0-25 ▪ BG 8 ▪ Nominal Size 25

Port A	Dimensions (mm/in)									Female Body		Weight (^{kg} /lbs) ca. per 100	Male Tip		Weight (^{kg} /lbs) ca. per 100
	ØE	ØF	L1	L2	L4 min	L5	SW1	SW2	Old Part Numbers	STAUFF Ordering Codes	Old Part Numbers		STAUFF Ordering Codes		
Female Thread according to DIN 3852 - ANSI B 1.20.3															
	G 1"	68	45	88	107	18	23	50	50	F025-1-IGF16-VA	137	F025-2-IGF16-VA	82,80		
		2.68	1.77	3.46	4.21	.71	.90	1.97	1.97	QRC-F0-25-F-G16-VT-W5	302.03	QRC-F0-25-M-G16-VT-W5	182.54		
	NPTF 1" -11 1/2	68	45	88	107	18	23	50	50	F025-1-INF16-VA	138,50	F025-2-INF16-VA	84		
		2.68	1.77	3.46	4.21	.71	.90	1.97	1.97	QRC-F0-25-F-NF16-VT-W5	305.34	QRC-F0-25-M-NF16-VT-W5	185.19		
	G 1 1/4"	68	45	88	107	18	23	50	50	F025-1-IGF20-VA	127,50	F025-2-IGF20-VA	86,80		
		2.68	1.77	3.46	4.21	.71	.90	1.97	1.97	QRC-F0-25-F-G20-VT-W5	281.09	QRC-F0-25-M-G20-VT-W5	191.36		
	NPTF 1 1/4" -11 1/2	68	45	88	107	18	23	50	50	F025-1-INF20-VA	128,90	F025-2-INF20-VA	880		
		2.68	1.77	3.46	4.21	.71	.90	1.97	1.97	QRC-F0-25-F-NF20-VT-W5	284.18	QRC-F0-25-M-NF20-VT-W5	1936.00		

Note: The connection of the two halves of a coupling is achieved depending on the type. It is important to observe the positive engagement of plug-type couplings and the secure tightening of screw-type couplings to the limit stop of the thread. Forced or improper separation will result in malfunction of the coupling.



Series HP - Carbon Steel

Series HP - Overview	42	Series HU-12 - BG 3 - Nominal Size 12,5 Connect Under Pressure	49
Series HP-06 - BG 1 - Nominal Size 6,3	43	Series HP-19 - BG 6 - Nominal Size 19	50
Series HP-10 - BG 2 - Nominal Size 10	44	Series HP-25 - BG 8 - Nominal Size 25	51
Series HP-10A - BG 2 - Nominal Size 10	45	Series HP and Series HU - Dust Protection	52
Series HP-12 - BG 3 - Nominal Size 12,5	46 - 47		
Series ZP-12 - BG 3 - Nominal Size 12,5	48		
Series AP-12 - BG 3 - Nominal Size 12,5	49		

HP/HU



Series HP ▪ Carbon Steel

Material	Carbon Steel
Surface Finishing	Zinc-Nickel ¹ , Zinc-Plating and Thick-Film-Passivation (Chrome III)
Standard Seal Material(s)	NBR (Buna-N®), PTFE ²
Working Temperature	-25° C ... +100° C / -13° F ... +212° F
Valve Design	Poppet Valve
Connection	Push (When mounting the Sleeve in Bulkhead), Push and actuate Push-Pull Sleeve
Disconnection	Pull (When mounting the Sleeve in Bulkhead), Actuate Push-Pull Sleeve
Connect Under Pressure	not allowed, (Male Tip Series HU up to the max. Working Pressure allowed)
Application	Agricultural and Forestry Machinery
ISO Interchange	ISO 7241-1 A and ISO 5675 (for selected sizes).



HP/HU

¹ Only Nominal Size 12,5
² Alternative seal materials are available on request.

Technical Data

Series	BG	DN Zoll	DN metric ISO 4397	Q _{max}		Working Pressure		Bursting Pressure Connected		Female Body		Male Tip		Spillage	
				l/min	US GPM	bar	PSI	bar	PSI	bar	PSI	bar	PSI	ml	fl oz
HP-06	1	1/4"	6,3	20	5.28	250	3626	1000	14504	1000	14504	1000	14504	0,8	.0271
HP-10	2	3/8"	10	40	10.57	250	3626	1000	14504	1000	14504	1000	14504	1,2	.0406
HP-12	3	1/2"	12,5	100	21.13	250	3626	1000	14504	1000	14504	1000	14504	1,7	.0575
HP-19	6	3/4"	19 (20)	120	31.70	250	3626	1000	14504	1000	14504	700	10153	8,0	.2705
HP-25	8	1"	25	160	42.27	250	3626	1000	14504	1000	14504	700	10153	12,0	.4058
HU-12	3	1/2"	12	90	23.77	250	3626	1100	15954	1500	21756	1000	14504	2,7	.0913

The indicated pressure ratings only apply to the coupling itself and depend on the connection type.

Flow Characteristics

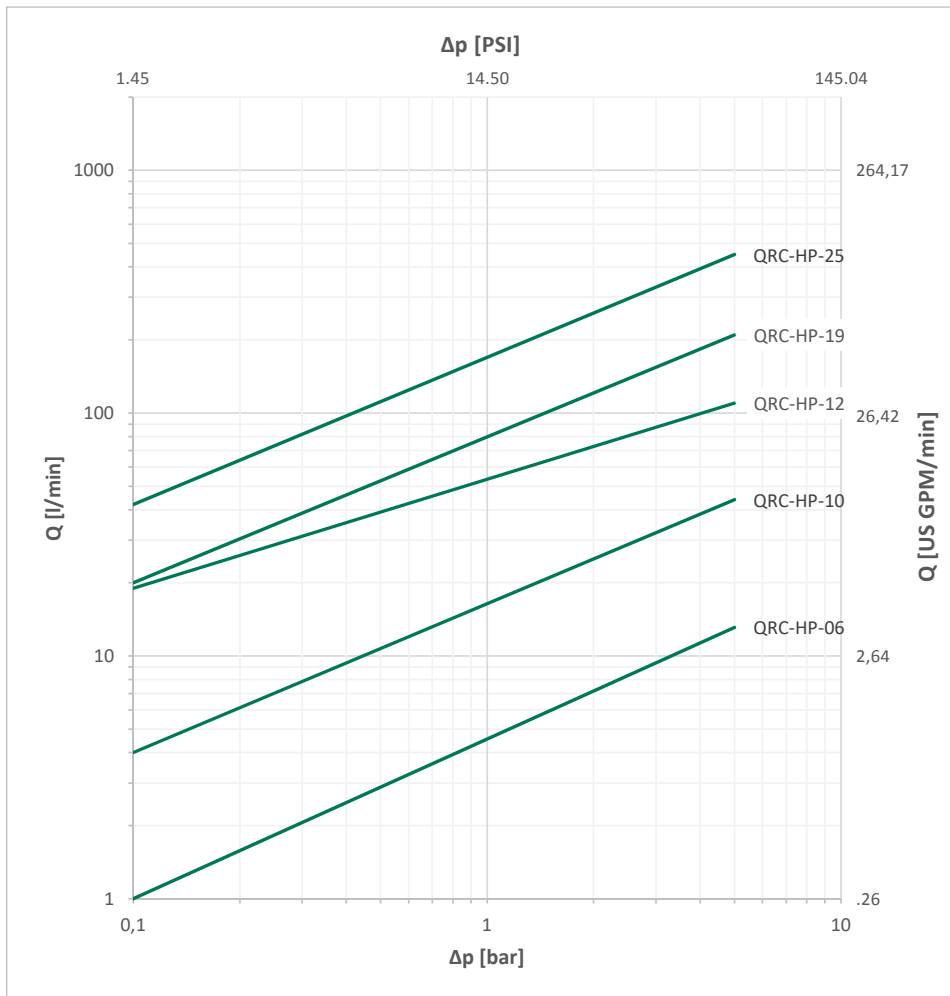

Please note: Unless otherwise stated, all flow characteristics have been determined with hydraulic oil with a kinematic viscosity of 28,8 - 35,2 mm²/s (28,8 - 35,2 cSt) and are only valid for components with non-reducing connections.



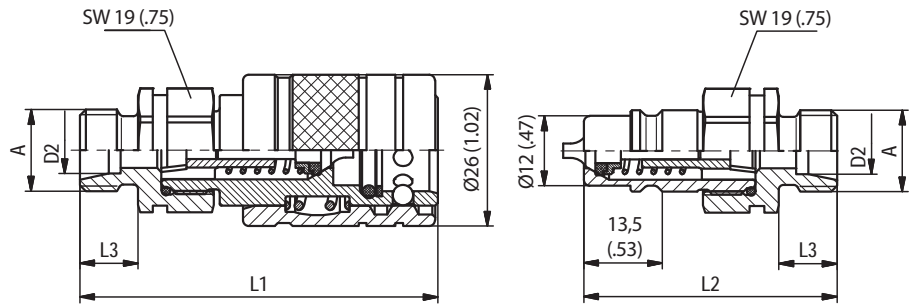

SW: Width across flats. All dimensions in mm (inch).

Series HP-06 • BG 1 • Nominal Size 6,3
HP/HU

Port A	Dimensions (^{mm} / _{in})					Female Body	Weight	Male Tip	Weight
	ØD2	L1	L2	L3	L4	Old Part Numbers STAUFF Ordering Codes	(^{kg} / _{lbs}) ca. per 100	Old Part Numbers STAUFF Ordering Codes	(^{kg} / _{lbs}) ca. per 100
Female Thread according to DIN 3852-2-A - ANSI B 1.20.3									
	G1/4"	64	44		13	HP04-1-IGF04	14,60	HP04-2-IGF04	5,20
		2.52	1.73		.51	QRC-HPA-06-F-G04-BT-W66	32.19	QRC-HPA-06-M-G04-B-W66	11.46
	NPTF 1/4" -18	64	44			HP04-1-INF04	15	HP04-2-INF04	5,20
		2.52	1.73			QRC-HPA-06-F-NF04-BT-W66	33.07	QRC-HPA-06-M-NF04-B-W66	11.46
Male Thread with 24° Conical Bore - Shape W according to DIN 3861									
	M14x1,5	8L	62	42	10	HP04-1-L0814	13,40	HP04-2-L0814	4
			2.44	1.65	.39		QRC-HPA-06-F-08L-BT-W66	29.54	QRC-HPA-06-M-08L-B-W66
Male Thread with 24° Conical Bore - Bulkhead - Shape W according to DIN 3861									
	M14x1,5	8L	77	59	25	HP04-1-N0814	15,40	HP04-2-N0814	6,20
			3.01	2.30	.98		QRC-HPA-06-F-08LB-BT-W66	33.95	QRC-HPA-06-M-08LB-B-W66

Note: The connection of the two halves of a coupling is achieved depending on the type. It is important to observe the positive engagement of plug-type couplings and the secure tightening of screw-type couplings to the limit stop of the thread. Forced or improper separation will result in malfunction of the coupling.



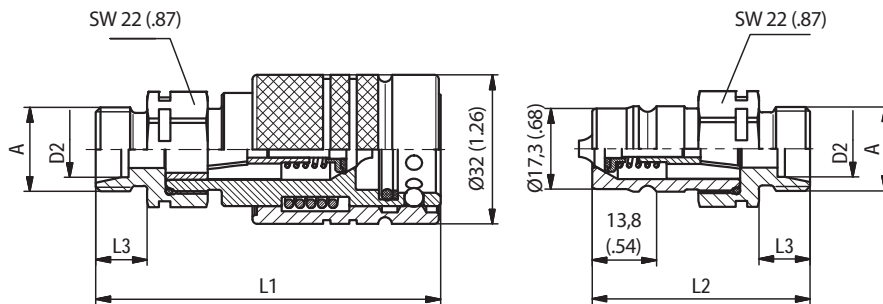

SW: Width across flats. All dimensions in mm (inch).

Dimensions acc. to ISO 7241-1, Series A, Size 10.

HP/HU

Series HP-10 • BG 2 • Nominal Size 10

Port A	Dimensions (^{mm} / _{in})					Female Body	Weight	Male Tip	Weight
	ØD2	L1	L2	L3	L4	Old Part Numbers STAUFF Ordering Codes	(^{kg} / _{lbs}) ca. per 100	Old Part Numbers STAUFF Ordering Codes	(^{kg} / _{lbs}) ca. per 100
Male Thread according to ISO 1179-4-B									
	G3/8"	77	51	12		HP08-1-AGF06	2,20	HP08-2-AGF06	7,80
		3.03	2.01	.47		QRC-HP-10-F-B06-BT-W66	4.85	QRC-HP-10-M-B06-B-W66	17.2
Female Thread according to DIN 3852-2-A - ISO 9974-1 - ANSI B 1.20.3									
	G1/4"	76	49		13	HP08-1-IGF04	19,50	HP08-2-IGF04	88
		2.99	1.93		.51	QRC-HP-10-F-G04-BT-W66	42.99	QRC-HP-10-M-G04-B-W66	193.60
	G3/8"	76	49		13	HP08-1-IGF06	18,80	HP08-2-IGF06	80
		2.99	1.93		.51	QRC-HP-10-F-G06-BT-W66	41.45	QRC-HP-10-M-G06-B-W66	176.00
	M16x1,5	76	49		13	HP08-1-IMF16	18,80	HP08-2-IMF16	81
		2.99	1.93		.51	QRC-HP-10-F-M16-BT-W66	41.45	QRC-HP-10-M-M16-B-W66	178.20
	NPTF 3/8"-18	76	49			HP08-1-INF06	18,80	HP08-2-INF06	81
		2.99	1.93			QRC-HP-10-F-NF06-BT-W66	41.45	QRC-HP-10-M-NF06-B-W66	178.20
Male Thread with 24° Conical Bore - Shape W according to DIN 3861									
	M14x1,5	8L	73	46	10	HP08-1-L0814	21	HP08-2-L0814	4,20
		2.87	1.81	.39		QRC-HP-10-F-08L-BT-W66	46.30	QRC-HP-10-M-08L-B-W66	9.26
	M16x1,5	10L	74	47	11	HP08-1-L1016	21	HP08-2-L1016	6,50
		2.91	1.85	.43		QRC-HP-10-F-10L-BT-W66	46.30	QRC-HP-10-M-10L-B-W66	14.33
	M18x1,5	12L	74	47	11	HP08-1-L1218	21,50	HP08-2-L1218	7,30
		2.91	1.84	.43		QRC-HP-10-F-12L-BT-W66	47.40	QRC-HP-10-M-12L-B-W66	16,09
	M16x1,5	8S	75	48	12	HP08-1-S0816	21,20	HP08-2-S0816	7,10
		2.95	1.89	.47		QRC-HP-10-F-08S-BT-W66	46.74	QRC-HP-10-M-08S-B-W66	15.65
	M18x1,5	10S	75	48	12	HP08-1-S1018	21,60	HP08-2-S1018	7,20
		2.95	1.89	.47		QRC-HP-10-F-10S-BT-W66	47.62	QRC-HP-10-M-10S-B-W66	15.87
	M20x1,5	12S	75	48	12	HP08-1-S1220	21,60	HP08-2-S1220	7,40
		2.95	1.89	.47		QRC-HP-10-F-12S-BT-W66	47.62	QRC-HP-10-M-12S-B-W66	16.31
Male Thread with 24° Conical Bore - Bulkhead - Shape W according to DIN 3861									
	M14x1,5	8L	88	61	25	HP08-1-N0814	22,80	HP08-2-N0814	8,40
		3.46	2.39	.98		QRC-HP-10-F-08LB-BT-W66	50.27	QRC-HP-10-M-08LB-B-W66	18.51
	M16x1,5	10L	89	62	26	HP08-1-N1016	23,40	HP08-2-N1016	9
		3.50	2.43	1.02		QRC-HP-10-F-10LB-BT-W66	51.59	QRC-HP-10-M-10LB-B-W66	19.84
	M18x1,5	12L	89	62	26	HP08-1-N1218	23,50	HP08-2-N1218	9,40
		3.50	2.43	1.02		QRC-HP-10-F-12LB-BT-W66	51.81	QRC-HP-10-M-12LB-B-W66	20.72
	M16x1,5	08S	90	63	27	HP08-1-T0816 *	23	HP08-2-T0816 *	10
		3.54	2.47	1.06		QRC-HP-10-F-08SB-BT-W66 *	50.71	QRC-HP-10-M-08SB-B-W66 *	22.05
	M20x1,5	12S	90	63	27	HP08-1-T1220 *	22	HP08-2-T1220 *	7,40
		3.54	2.47	1.06		QRC-HP-10-F-12SB-BT-W66 *	48.50	QRC-HP-10-M-12SB-B-W66 *	16.31

* Available on request.

Note: The connection of the two halves of a coupling is achieved depending on the type. It is important to observe the positive engagement of plug-type couplings and the secure tightening of screw-type couplings to the limit stop of the thread. Forced or improper separation will result in malfunction of the coupling.



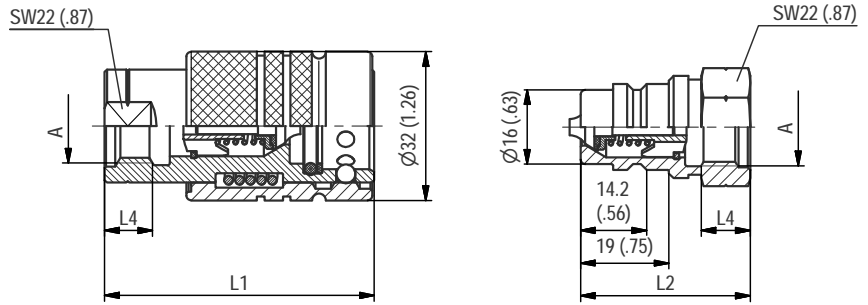

SW: Width across flats. All dimensions in mm (inch).

Series HP-10A ▪ BG 2 ▪ Nominal Size 10
HP/HU

Port A	Dimensions (mm/in)					Female Body	Weight	Male Tip	Weight
	ØD2	L1	L2	L3	L4	Old Part Numbers STAUFF Ordering Codes	(kg/lbs) ca. per 100	Old Part Numbers STAUFF Ordering Codes	(kg/lbs) ca. per 100
Female Thread according to DIN 3852-2-A - ANSI B 1.20.3									
	G3/8"	58	37	14		HP08A1-IGF06	18,80	HP08A2-IGF06	5,10
		2.28	1.46	.55		QRC-HPA-10-F-G06-BT-W66	41.45	QRC-HPA-10-M-G06-B-W66	11.24
Male Thread with 24° Conical Bore - Bulkhead - Shape W according to DIN 3861									
	M16x1,5	10L	58	37	14	HP08A1-L1016	22,60	HP08A2-L1016	8,80
			2.28	1.44	.55		QRC-HPA-10-F-10L-BT-W66	49.82	QRC-HPA-10-M-10L-B-W66

Note: The connection of the two halves of a coupling is achieved depending on the type. It is important to observe the positive engagement of plug-type couplings and the secure tightening of screw-type couplings to the limit stop of the thread. Forced or improper separation will result in malfunction of the coupling.



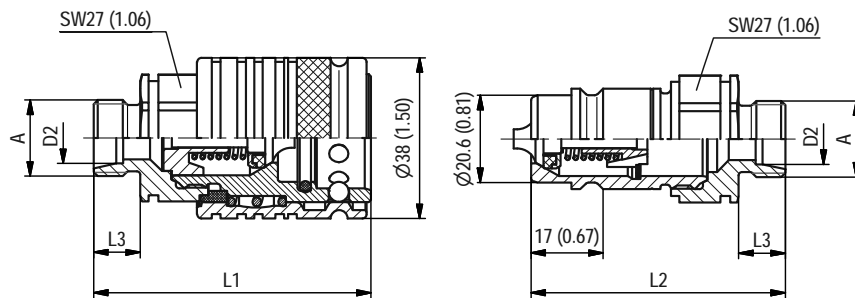

SW: Width across flats. All dimensions in mm (inch).

Dimensions acc. to ISO 7241-1, Series A, Size 12,5 and ISO 5675.

HP/HU

Series HP-12 ▪ BG 3 ▪ Nominal Size 12,5

Port A	Dimensions (^{mm} / _{in})					Female Body	Weight	Male Tip	Weight
	ØD2	L1	L2	L3	L4	Old Part Numbers STAUFF Ordering Codes	(^{kg} / _{lbs}) ca. per 100	Old Part Numbers STAUFF Ordering Codes	(^{kg} / _{lbs}) ca. per 100
Male Thread according to ISO 1179-4-B - ISO 9974-3									
	G 3/8"	71	61	12		HP10-1-AGF06N	29	HP10-2-AGF06N	11,90
		2.80	2.40	.47		QRC-HP-12-F-B06-B-W3	63.93	QRC-HP-12-M-B06-B-W3	26.24
	G 1/2"	71	61	12		HP10-1-AGF08N	29,60	HP10-2-AGF08N	12,30
		2.80	2.40	.47		QRC-HP-12-F-B08-B-W3	65.26	QRC-HP-12-M-B08-B-W3	27.12
	M22x1,5	71	61	12		HP10-1-AMF22N	30	HP10-2-AMF22N	12,90
		2.80	2.40	.47		QRC-HP-12-F-M22M-B-W3	66.14	QRC-HP-12-M-M22M-B-W3	28.44
Female Thread according to DIN 3852-2-A - ISO 6149-1 - ISO 9974-1 - ANSI B 1.20.3 - SAE J1926-1									
	G3/8"	68	60		15	HP10-1-IGF06N	33,10	HP10-2-IGF06N	15,30
		2.68	2.36		.59	QRC-HP-12-F-G06-B-W3	72.97	QRC-HP-12-M-G06-B-W3	33.73
	G 1/2"	70	48		17	HP10-1-IGF08N	28	HP10-2-IGF08N	9,20
		2.76	1.89		.67	QRC-HP-12-F-G08-B-W3	61.73	QRC-HP-12-M-G08-B-W3	20.28
	M16x1,5	67	62		15	HP10-1-IMF16N	31,80	HP10-2-IMF16N	16
		2.65	2.43		.59	QRC-HP-12-F-M160R-B-W3	70.11	QRC-HP-12-M-M160R-B-W3	35.27
	M18x1,5	68	60		15	HP10-1-IMF18N	31,80	HP10-2-IMF18N	14,70
		2.68	2.36		.59	QRC-HP-12-F-M180R-B-W3	70.11	QRC-HP-12-M-M180R-B-W3	32.41
	M22x1,5	70	48		17	HP10-1-IMF22N	28,40	HP10-2-IMF22N	8,80
		2.76	1.89		.67	QRC-HP-12-F-M22-B-W3	62.61	QRC-HP-12-M-M220R-B-W3	19.40
	NPTF 1/2"-14	70	48			HP10-1-INF08N	29,40	HP10-2-INF08N	9,40
		2.76	1.89			QRC-HP-12-F-NF08-B-W3	64.82	QRC-HP-12-M-NF08-B-W3	20.27
	UNF 3/4"-16	77	48		14	HP10-1-IUF08N	27,80	HP10-2-IUF08N	8,80
		3.03	1.89		.55	QRC-HP-12-F-U08-B-W3	61.29	QRC-HP-12-M-U08-B-W3	19.40

Note: The connection of the two halves of a coupling is achieved depending on the type. It is important to observe the positive engagement of plug-type couplings and the secure tightening of screw-type couplings to the limit stop of the thread. Forced or improper separation will result in malfunction of the coupling.



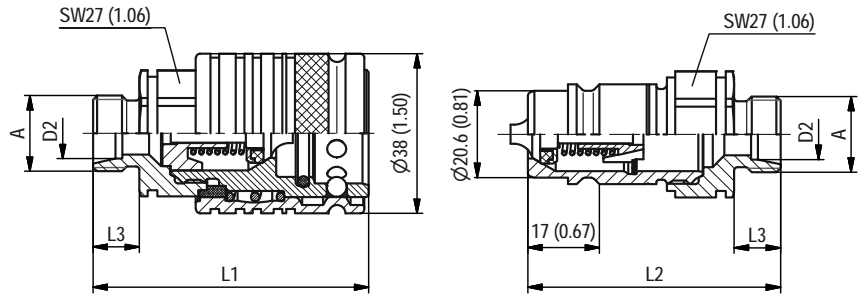

SW: Width across flats. All dimensions in mm (inch).

Dimensions acc. to ISO 7241-1, Series A, Size 12,5 and ISO 5675.

Series HP-12 ▪ BG 3 ▪ Nominal Size 12,5
HP/HU

Port A	Dimensions (^{mm} / _{in})					Female Body	Weight	Male Tip	Weight	
	ØD2	L1	L2	L3	L4	Old Part Numbers STAUFF Ordering Codes	(^{kg} / _{lbs}) ca. per 100	Old Part Numbers STAUFF Ordering Codes	(^{kg} / _{lbs}) ca. per 100	
Male Thread with 24° Conical Bore - Shape W according to DIN 3861										
	M14x1,5	8L	64 2.53	58 2.30	10 .39	HP10-1-L0814N QRC-HP-12-F-08L-B-W3	26,20 57.76	HP10-2-L0814N QRC-HP-12-M-08L-B-W3	10,70 23.59	
	M16x1,5	10L	65 2.57	60 2.35	11 .43	HP10-1-L1016N QRC-HP-12-F-10L-B-W3	25,70 56.66	HP10-2-L1016N QRC-HP-12-M-10L-B-W3	10,90 24.03	
	M18x1,5	12L	65 2.57	60 2.35	11 .43	HP10-1-L1218N QRC-HP-12-F-12L-B-W3	25,70 56.66	HP10-2-L1218N QRC-HP-12-M-12L-B-W3	10,90 24.03	
	M22x1,5	15L	66 2.61	61 2.39	12 .47	HP10-1-L1522N QRC-HP-12-F-15L-B-W3	26,50 58.42	HP10-2-L1522N QRC-HP-12-M-15L-B-W3	11,70 25.79	
	M26x1,5	18L	66 2.61	61 2.39	12 .47	HP10-1-L1826N QRC-HP-12-F-18L-B-W3	27,30 60.19	HP10-2-L1826N QRC-HP-12-M-18L-B-W3	11,90 26.24	
	M18x1,5	10S	66 2.61	61 2.39	12 .47	HP10-1-S1018N QRC-HP-12-F-10S-B-W3	26,50 58.42	HP10-2-S1018N QRC-HP-12-M-10S-B-W3	11,50 25.35	
	M20x1,5	12S	66 2.61	61 2.39	12 .47	HP10-1-S1220N QRC-HP-12-F-12S-B-W3	26,70 58.86	HP10-2-S1220N QRC-HP-12-M-12S-B-W3	11,70 25.79	
	M22x1,5	14S	68 2.69	63 2.47	14 .55	HP10-1-S1422N QRC-HP-12-F-14S-B-W3	27,30 60.19	HP10-2-S1422N QRC-HP-12-M-14S-B-W3	12,30 27.12	
	M24x1,5	16S	68 2.69	63 2.47	14 .55	HP10-1-S1624N QRC-HP-12-F-16S-B-W3	27,50 60.63	HP10-2-S1624N QRC-HP-12-M-16S-B-W3	12,50 27.56	
	Male Thread with 24° Conical Bore - Bulkhead - Shape W according to DIN 3861									
		M14x1,5	08L	80 3.16	75 2.94	26 1.02	HP10-1-N0814N QRC-HP-12-F-08LB-B-W3	28,20 62.17	HP10-2-N0814N QRC-HP-12-M-08LB-B-W3	12,90 28.44
		M16x1,5	10L	80 3.16	75 2.94	26 1.02	HP10-1-N1016N QRC-HP-12-F-10LB-B-W3	28,80 63.49	HP10-2-N1016N QRC-HP-12-M-10LB-B-W3	13,50 29.76
		M18x1,5	12L	84 3.31	79 3.10	30 1.18	HP10-1-N1218N QRC-HP-12-F-12LB-B-W3	29,10 64.15	HP10-2-N1218N QRC-HP-12-M-12LB-B-W3	14,30 31.53
		M22x1,5	15L	81 3.19	76 2.98	27 1.06	HP10-1-N1522N QRC-HP-12-F-15LB-B-W3	30,70 67.68	HP10-2-N1522N QRC-HP-12-M-15LB-B-W3	15,90 35.05
		M26x1,5	18L	81 3.20	76 2.98	27 1.06	HP10-1-N1826N QRC-HP-12-F-18LB-B-W3	34,10 75.18	HP10-2-N1826N QRC-HP-12-M-18LB-B-W3	19,30 42.55
		M18x1,5	10S	80 3.16	75 2.94	26 1.02	HP10-1-T1018N QRC-HP-12-F-10SB-B-W3	29,70 65.48	HP10-2-T1018N QRC-HP-12-M-10SB-B-W3	14,70 32.41
M20x1,5		12S	81 3.20	76 2.98	27 1.06	HP10-1-T1220N QRC-HP-12-F-12SB-B-W3	30,50 67.24	HP10-2-T1220N QRC-HP-12-M-12SB-B-W3	15,50 34.17	
M22x1,5		14S	83 3.28	78 3.06	29 1.14	HP10-1-T1422N QRC-HP-12-F-14SB-B-W3	31,90 70.33	HP10-2-T1422N QRC-HP-12-M-14SB-B-W3	17,10 37.70	
M24x1,5		16S	83 3.28	78 3.06	29 1.14	HP10-1-T1624N QRC-HP-12-F-16SB-B-W3	33,30 73.41	HP10-2-T1624N QRC-HP-12-M-16SB-B-W3	18,30 40.34	

Note: The connection of the two halves of a coupling is achieved depending on the type. It is important to observe the positive engagement of plug-type couplings and the secure tightening of screw-type couplings to the limit stop of the thread. Forced or improper separation will result in malfunction of the coupling.



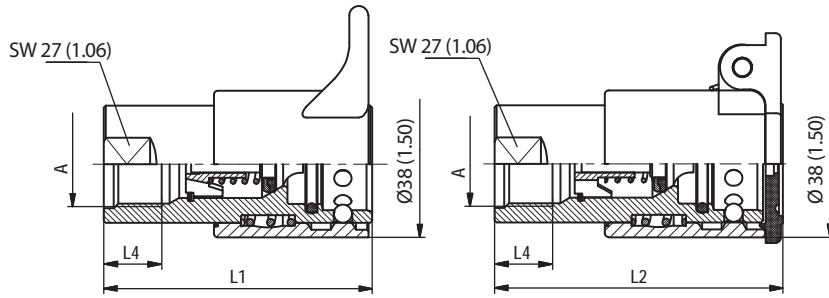





SW: Width across flats. All dimensions in mm (inch).

Dimensions acc. to ISO 7241-1, Series A, Size 12,5 and ISO 5675.

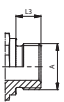
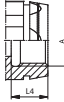
HP/HU

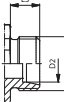
Series ZP-12 ▪ BG 3 ▪ Nominal Size 12,5

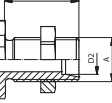
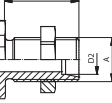
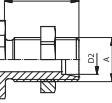
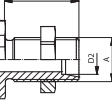
Port A	Dimensions (^{mm} / _{in})					Female Body	Weight	Female Body with Dust Plug	Weight
	ØD2	L1	L2	L3	L4	Old Part Numbers STAUFF Ordering Codes	(^{kg} / _{lbs}) ca. per 100	Old Part Numbers STAUFF Ordering Codes	(^{kg} / _{lbs}) ca. per 100
Male Thread according to DIN 3852									
 G 1/2"		74		12		ZP10-1-AGF08	31,40		
		2.92		.47		QRC-ZP-12-F-B08-B-W66	69.23		
Female Thread according to DIN 3852-2 - ISO 9974-1									
 G1/2"		70			17	ZP10-1-IGF08	31,40		
		2.76			.67	QRC-ZP-12-F-G08-B-W66	69.23		
 M22x1,5		70	75		17	ZP10-1-IMF22	31	ZP10-5-IMF22C1	30,50
		2.76	2.95		.67	QRC-ZP-12-F-M22-B-W66	68.34	QRC-ZP-12-FF-M22/L-B-W66-SW	67.24
Male Thread with 24° Conical Bore - Shape W according to DIN 3861									
 M18x1,5	12L	70			11	ZP10-1-L1218	30,10		
		2.76		.43		QRC-ZP-12-F-12L-B-W66	66.36		
 M22x1,5	15L	71			12	ZP10-1-L1522	30,90		
		2.80		.47		QRC-ZP-12-F-15L-B-W66	68.12		
Male Thread with 24° Conical Bore - Bulkhead - Shape W according to DIN 3861									
 M18x1,5	12L	89	93	30		ZP10-1-N1218	33,50	ZP10-5-N1218C1	36,20
		3.51	3.67	1.18		QRC-ZP-12-F-12LB-B-W66	73.85	QRC-ZP-12-FF-12LB/S-B-W66-SW	79.81
 M22x1,5	15L	86	90	27		ZP10-1-N1522	35,10	ZP10-5-N1522C1	38,90
		3.39	3.55	1.06		QRC-ZP-12-F-15LB-B-W66	77.38	QRC-ZP-12-FF-15LB/S-B-W66-SW	85.76
 M20x1,5	12S		90	27				ZP10-5-T1220C1	39,30
			3.55	1.06				QRC-ZP-12-FF-12SB/L-B-W66-SW	86.64
 M24x1,5	16S		92	29				ZP10-5-T1624C1	41,50
			3.63	1.14				QRC-ZP-12-FF-16SB/L-B-W66-SW	91.49

Note: The connection of the two halves of a coupling is achieved depending on the type. It is important to observe the positive engagement of plug-type couplings and the secure tightening of screw-type couplings to the limit stop of the thread. Forced or improper separation will result in malfunction of the coupling.



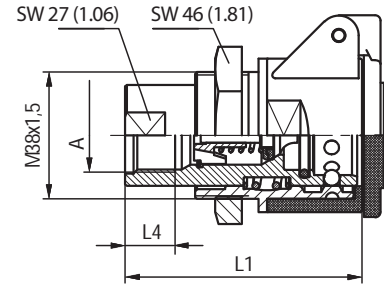
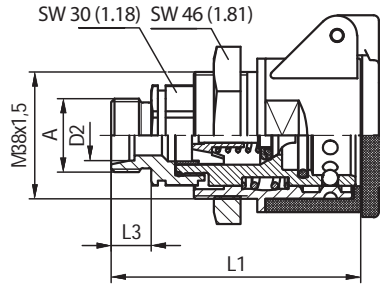

SW: Width across flats. All dimensions in mm (inch).

Dimensions acc. to ISO 7241-1, Series A, Size 12,5 and ISO 5675.

Series AP-12 • BG 3 • Nominal Size 12,5
HP/HU

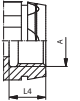
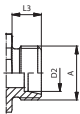
Port A	Dimensions (mm/in)					Female Body		Weight (kg/lbs) ca. per 100
	ØD2	L1	L2	L3	L4	Old Part Numbers	STAUFF Ordering Codes	
Innengewinde entsprechend ISO 9974-1								
	M22x1,5	75			15	AP10-5-I2230A1		38,10
		2.95			.59	QRC-AP-12-FF-M22M30-B-W66-RD/BK		84
Male Thread with 24° Conical Bore - Shape W according to DIN 3861								
	M22x1,5	15L	72		12	AP10-5-L1522A1		39
		2.84		.47		QRC-AP-12-FF-15L-B-W66-RD/BK		85.98

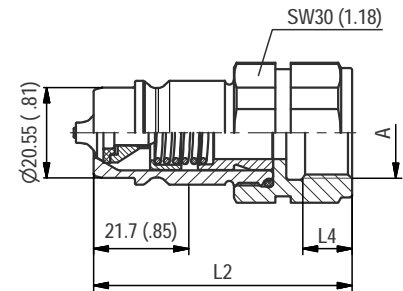

SW: Width across flats. All dimensions in mm (inch).

 Male Tip Connect Under Pressure - use our HP-10 Female side.
 Dimensions acc. to ISO 7241-1, Series A

Series HU-12 • BG 3 • Nominal Size 12,5 • Connect Under Pressure

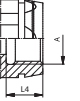
Port A	Dimensions (mm/in)					Male Tip		Weight (kg/lbs) ca. per 100
	ØD2	L1	L2	L3	L4	Old Part Numbers	STAUFF Ordering Codes	
Female Thread according to DIN 3852-2-A - ANSI B 1.20.3								
	G3/8"	72	59		12	HU12-2-IGF06		16,60
		2.83	2.32		.47	QRC-HU-12-M-G06-B-W66		36.60
	NPTF 3/8" -18	74,5	61,5			HU12-2-INF06		19,20
		2.93	2.42			QRC-HU-12-M-NF06-B-W66		42.33
	G1/2"	72	59		14	HU12-2-IGF08		16,20
		2.83	2.32		.55	QRC-HU-12-M-G08-B-W66		35.71
NPTF 1/2" -14	75	62			HU12-2-INF08		17,60	
	2.95	2.44			QRC-HU-12-M-NF08-B-W66		38.80	

Note: The connection of the two halves of a coupling is achieved depending on the type. It is important to observe the positive engagement of plug-type couplings and the secure tightening of screw-type couplings to the limit stop of the thread. Forced or improper separation will result in malfunction of the coupling.



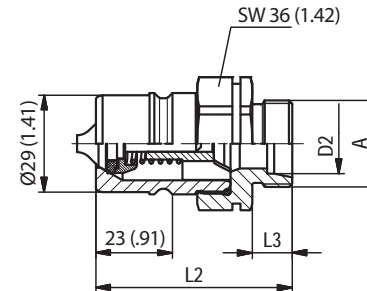
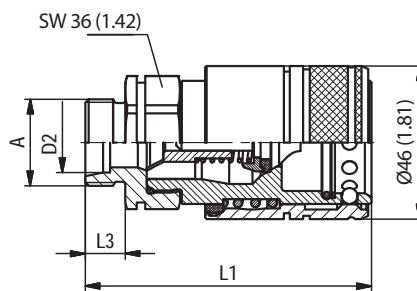

SW: Width across flats. All dimensions in mm (inch).

Dimensions acc. to ISO 7241-1, Series A, Size 19 and ISO 5675.

HP/HU

Series HP-19 • BG 6 • Nominal Size 19

Port A	Dimensions (mm/in)					Female Body	Weight	Male Tip	Weight	
	ØD2	L1	L2	L3	L4	Old Part Numbers STAUFF Ordering Codes	(^{kg} /lbs) ca. per 100	Old Part Numbers STAUFF Ordering Codes	(^{kg} /lbs) ca. per 100	
Female Thread according to DIN 3852-2 - ISO 9974-1										
	G3/4"	92	65		19	HP12-1-IGF12	60,50	HP12-2-IGF12	31,50	
	M22x1,5	3.62	2.56		.75	QRC-HP-19-F-G12-BT-W66	133.38	QRC-HP-19-M-G12-B-W66	69.45	
		3.62	2.56		.75	HP12-1-IMF22	62,80	HP12-2-IMF22	31,30	
NPTF 3/4"-14	92	65			QRC-HP-19-F-M22-BT-W66	138.45	QRC-HP-19-M-M22-B-W66	69		
	3.62	2.56			HP12-1-INF12	62,80	HP12-2-INF12	31,30		
Male Thread with 24° Conical Bore - Shape W according to DIN 3861										
	M18x1,5	12L	85	58	11		HP12-1-L1218	54,40	HP12-2-L1218	22,70
		3.35	2.28	.43		QRC-HP-19-F-12L-BT-W66	119.93	QRC-HP-19-M-12L-B-W66	50.04	
	M22x1,5	15L	86	59	12		HP12-1-L1522	54,60	HP12-2-L1522	23,20
			3.39	2.32	.47		QRC-HP-19-F-15L-BT-W66	120.37	QRC-HP-19-M-15L-B-W66	51.15
	M26x1,5	18L	86	59	12		HP12-1-L1826	55,50	HP12-2-L1826	23,80
			3.39	2.32	.47		QRC-HP-19-F-18L-BT-W66	122.36	QRC-HP-19-M-18L-B-W66	52.47
	M30x2	22L	88	61	14		HP12-1-L2230	56,90	HP12-2-L2230	24,80
			3.46	2.40	.55		QRC-HP-19-F-22L-BT-W66	125.44	QRC-HP-19-M-22L-B-W66	54.67
	M24x1,5	16S	88	61	14		HP12-1-S1624	56	HP12-2-S1624	24,20
			3.46	2.40	.55		QRC-HP-19-F-16S-BT-W66	123.46	QRC-HP-19-M-16S-B-W66	53.35
	M30x2	20S	90	63	16		HP12-1-S2030	57,20	HP12-2-S2030	25,20
			3.54	2.48	.63		QRC-HP-19-F-20S-BT-W66	126.10	QRC-HP-19-M-20S-B-W66	55.56
Male Thread with 24° Conical Bore - Bulkhead - Shape W according to DIN 3861										
	M18x1,5	12L	100	73	26		HP12-1-N1218	57,40	HP12-2-N1218	27,60
			3.94	2.87	1.02		QRC-HP-19-F-12LB-BT-W66	126.55	QRC-HP-19-M-12LB-B-W66	60.85
	M22x1,5	15L	101	74	27		HP12-1-N1522	59	HP12-2-N1522	27,40
			3.98	2.91	1.06		QRC-HP-19-F-15LB-BT-W66	130.07	QRC-HP-19-M-15LB-B-W66	60.41
	M26x1,5	18L	101	74	27		HP12-1-N1826	62,70	HP12-2-N1826	31
			3.98	2.91	1.06		QRC-HP-19-F-18LB-BT-W66	138.23	QRC-HP-19-M-18LB-B-W66	68.34
	M30x2	22L	110	83	36		HP12-1-N2230	67,50	HP12-2-N2230	35,50
			4.33	3.27	1.42		QRC-HP-19-F-22LB-BT-W66	148.81	QRC-HP-19-M-22LB-B-W66	78.26
	M24x1,5	16S	103	76	29		HP12-1-T1624	61,40	HP12-2-T1624	29,80
			4.06	2.99	1.14		QRC-HP-19-F-16SB-BT-W66	135.36	QRC-HP-19-M-16SB-B-W66	65.70
	M30x2	20S	110	83	36		HP12-1-T2030	68,50	HP12-2-T2030	36,20
			4.33	3.27	1.42		QRC-HP-19-F-20SB-BT-W66	151.02	QRC-HP-19-M-20SB-B-W66	79.81

Note: The connection of the two halves of a coupling is achieved depending on the type. It is important to observe the positive engagement of plug-type couplings and the secure tightening of screw-type couplings to the limit stop of the thread. Forced or improper separation will result in malfunction of the coupling.



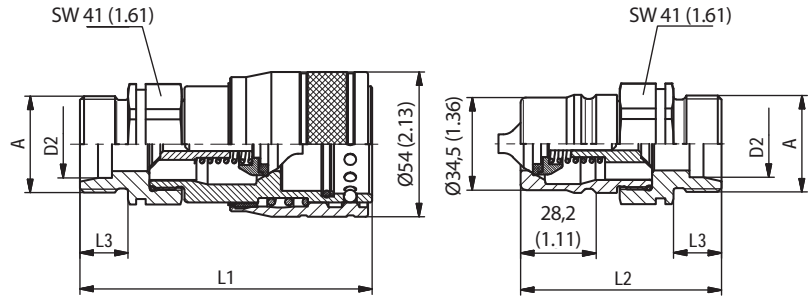

SW: Width across flats. All dimensions in mm (inch).

Dimensions acc. to ISO 7241-1, Series A, Size 25.

Series HP-25 ▪ BG 8 ▪ Nominal Size 25
HP/HU

Port A	Dimensions (^{mm} / _{in})				Female Body		Weight (^{kg} / _{lbs}) ca. per 100	Male Tip		Weight (^{kg} / _{lbs}) ca. per 100
	ØD2	L1	L2	L3	L4	Old Part Numbers STAUFF Ordering Codes		Old Part Numbers STAUFF Ordering Codes		
Female Thread according to DIN 3852-2-A - ANSI B 1.20.3										
	G3/4"	104	72		19	HP20-1-IGF12	87,60	HP20-2-IGF12	40,90	
	G1"	4.09	2.83		.75	QRC-HP-25-F-G12-BT-W66	193.12	QRC-HP-25-M-G12-B-W66	90.17	
		4.09	2.83		.75	QRC-HP-25-F-G16-BT-W66	183.87	QRC-HP-25-M-G16-B-W66	80.03	
NPTF 1"-11 1/2	104	72			HP20-1-INF16	83,40	HP20-2-INF16	36,30		
	4.09	2.83			QRC-HP-25-F-NF16-BT-W66	183.87	QRC-HP-25-M-NF16-B-W66	80.03		
Male Thread with 24° Conical Bore - Shape W according to DIN 3861										
	M22x1,5	15L	103	69	12	HP20-1-L1522 *	79,70	HP20-2-L1522 *	34,60	
		4.06	2.72	.47		QRC-HP-25-F-15L-BT-W66	175.71	QRC-HP-25-M-15L-B-W66	76.28	
	M26x1,5	18L	103	69	12	HP20-1-L1826	81,30	HP20-2-L1826	34,80	
		4.06	2.72	.47		QRC-HP-25-F-18L-BT-W66	179.24	QRC-HP-25-M-18L-B-W66	76.72	
	M30x2	22L	105	71	14	HP20-1-L2230	81,70	HP20-2-L2230	35,50	
		4.13	2.80	.55		QRC-HP-25-F-22L-BT-W66	180.12	QRC-HP-25-M-22L-B-W66	78.26	
	M36x2	28L	105	71	14	HP20-1-L2836	81,90	HP20-2-L2836	36	
		4.13	2.80	.55		QRC-HP-25-F-28L-BT-W66	180.56	QRC-HP-25-M-28L-B-W66	79.37	
	M45x2	35L	107	73	16	HP20-1-L3545 *	89,60	HP20-2-L3545 *	44,50	
		4.21	2.87	.63		QRC-HP-25-F-35L-BT-W66	197.53	QRC-HP-25-M-35L-B-W66	98.11	
	M30x2	20S	107	73	16	HP20-1-S2030	82,80	HP20-2-S2030	36,10	
		4.21	2.87	.63		QRC-HP-25-F-20S-BT-W66	182.54	QRC-HP-25-M-20S-B-W66	79.59	
M36x2	25S	109	75	18	HP20-1-S2536	85	HP20-2-S2536	38		
	4.29	2.95	.71		QRC-HP-25-F-25S-BT-W66	187.39	QRC-HP-25-M-25S-B-W66	83.78		
M42x2	30S	111	77	20	HP20-1-S3042	82	HP20-2-S3042	44		
	4.37	3.03	.79		QRC-HP-25-F-30S-BT-W66	180.78	QRC-HP-25-M-30S-B-W66	97		
Male Thread with 24° Conical Bore - Bulkhead - Shape W according to DIN 3861										
	M22x1,5	15L	118	84	27	HP20-1-N1522	82,90	HP20-2-N1522 *	37,80	
		4.65	3.31	1.06		QRC-HP-25-F-15LB-BT-W66	182.76	QRC-HP-25-M-15LB-B-W66	83.33	
	M26x1,5	18L	123	89	32	HP20-1-N1826	85	HP20-2-N1826	42,80	
		4.84	3.50	1.26		QRC-HP-25-F-18LB-BT-W66	187.39	QRC-HP-25-M-18LB-B-W66	94.36	
	M30x2	22L	125	91	34	HP20-1-N2230	90,90	HP20-2-N2230	44	
		4.92	3.58	1.34		QRC-HP-25-F-22LB-BT-W66	200.40	QRC-HP-25-M-22LB-B-W66	97	
	M36x2	28L	125	91	34	HP20-1-N2836	85,40	HP20-2-N2836	48,10	
		4.92	3.58	1.34		QRC-HP-25-F-28LB-BT-W66	188.27	QRC-HP-25-M-28LB-B-W66	106.04	
	M30x2	20S	129	95	38	HP20-1-T2030	83,50	HP20-2-T2030	47,40	
		5.08	3.74	1.50		QRC-HP-25-F-20SB-BT-W66	184.09	QRC-HP-25-M-20SB-B-W66	104.50	
	M36x2	25S	129	95	38	HP20-1-T2536	89	HP20-2-T2536	52,40	
		5.08	1.38	1.50		QRC-HP-25-F-25SB-BT-W66	196.21	QRC-HP-25-M-25SB-B-W66	115.52	
M42x2	30S	131	97	40	HP20-1-T3042	111,90	HP20-2-T3042	63,40		
	5.16	3.82	1.57		QRC-HP-25-F-30SB-BT-W66	246.70	QRC-HP-25-M-30SB-B-W66	139.77		

* Available on request.

Note: The connection of the two halves of a coupling is achieved depending on the type. It is important to observe the positive engagement of plug-type couplings and the secure tightening of screw-type couplings to the limit stop of the thread. Forced or improper separation will result in malfunction of the coupling.



Series HP • Dust Protection

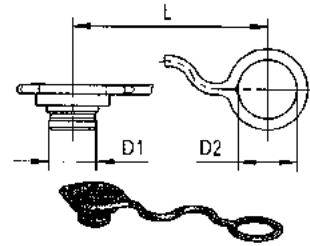
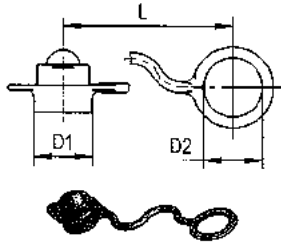

HP/HU

Dimensions (mm/in)			Material	Dust Cap for Male Tip	
D1	D2	L		Old Part Numbers	STAUFF Ordering Codes
28	27	134	Plastic (Colour: Red)	HP10-0-RT004	
1.10	1.06	5.28		QRC-HP-12-DM-27-K/1-RD	

Dimensions (mm/in)			Material	Dust Plug for Female Body	
D1	D2	L		Old Part Numbers	STAUFF Ordering Codes
22	27	135	Plastic (Colour: Red)	HP10-9-RT004	
.87	1.06	5.31		QRC-HP-12-DF-27-K/1-RD	

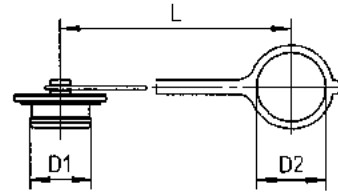
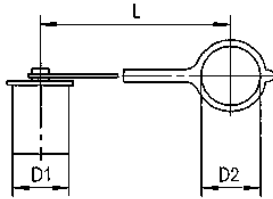

Dimensions (mm/in)			Material	Dust Cap for Male Tip	
D1	D2	L		Old Part Numbers	STAUFF Ordering Codes
22	22	125	Plastic (Colour: Red)	HP08-0-RT001	
.87	.87	4.92		QRC-HP-10-DM-22-K-RD	
33	37	190	Plastic (Colour: Red)	HP12-0-RT001	
1.30	1.46	7.48		QRC-HP-19-DM-37-K-RD	
36	41	190	Plastic (Colour: Red)	HP20-0-RT001	
1.42	1.61	7.48		QRC-HP-25-DM-41-K-RD	

Dimensions (mm/in)			Material	Dust Plug for Female Body	
D1	D2	L		Old Part Numbers	STAUFF Ordering Codes
18	22	125	Plastic (Colour: Red)	HP08-9-RT001	
.71	.87	4.92		QRC-HP-10-DF-22-K-RD	
30	37	190	Plastic (Colour: Red)	HP12-9-RT001	
1.18	1.46	7.48		QRC-HP-19-DF-37-K-RD	
36	41	190	Plastic (Colour: Red)	HP20-9-RT001	
1.42	1.61	7.48		QRC-HP-25-DF-41-K-RD	

Series HU • Dust Protection

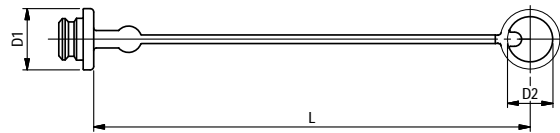
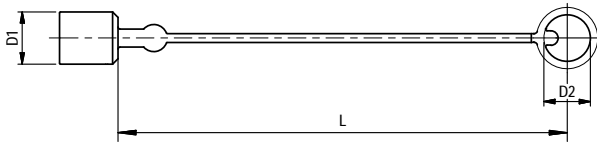

Dimensions (mm/in)			Material	Dust Cap for Male Tip	
D1	D2	L		Old Part Numbers	STAUFF Ordering Codes
29	26	250	Plastic (Colour: Red)	IA12-0-RT001	
1.14	1.02	9.84		QRC-IA-12-DM-26-W66-RD	

Dimensions (mm/in)			Material	Dust Plug for Female Body	
D1	D2	L		Old Part Numbers	STAUFF Ordering Codes
35	26	250	Plastic (Colour: Red)	IA12-9-RT001	
1.38	1.02	9.84		QRC-IA-12-DF-26-W66-RD	

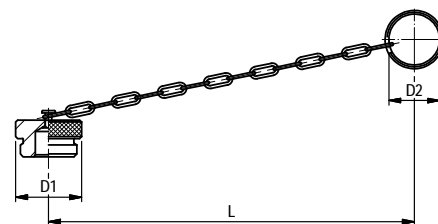
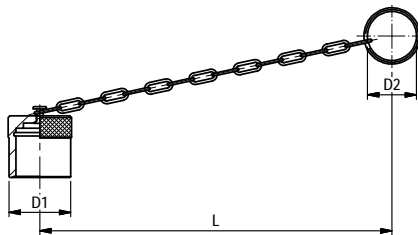

Dimensions (mm/in)			Material	Dust Cap for Male Tip	
D1	D2	L		Old Part Numbers	STAUFF Ordering Codes
38	32	205	Aluminium with chain	IA12-0-SI001	
1.50	1.26	8.07		QRC-IA-12-DM-32/CN-W89-SI	

Dimensions (mm/in)			Material	Dust Plug for Female Body	
D1	D2	L		Old Part Numbers	STAUFF Ordering Codes
38	32	205	Aluminium with chain	IA12-9-SI001	
1.50	1.26	8.07		QRC-IA-12-DF-32/CN-W89-SI	

In addition to the standard colours as stated above, plastic dust caps are also available in blue, green, yellow and black. Please use the old color codes BL, GN, GE and SW respectively instead of RT. Please use the STAUFF codes BU, GN, YE and BK respectively instead of RD.



Series UX • Carbon Steel

Series UX • Overview	54
Series UX-S-12 • BG 3 • Nominal Size 12,5 short version	55
Series UX-L-12 • BG 3 • Nominal Size 12,5 long version	56

UX



Series UX ▪ Carbon Steel

Material	Carbon Steel
Surface Finishing	Zinc-Plating and Thick-Film-Passivation (Chrome III)
Standard Seal Material(s)	NBR (Buna-N®), PTFE ²
Working Temperature	-30° C ... +100° C / -22° F ... +212° F
Valve Design	Poppet Valve
Connection	Push
Disconnection	Pull
Connect Under Pressure	Female Body with ISO-A Male Tip up to the max. Working Pressure allowed
Application	Agricultural and Forestry Machinery
ISO Interchange	ISO 7241-1 Series A, Size 12,5

² Alternative seal materials are available on request.



The series UX coupling sleeve is available in two different overall lengths and is therefore compatible with the common commercially available built-in couplings.

Technical Data

Series	BG	DN Zoll	DN metric ISO 4397	Q _{max}		Working Pressure		Bursting Pressure Connected		Female Body		Male Tip		Spillage	
				l/min	US GPM	bar	PSI	bar	PSI	bar	PSI	bar	PSI	ml	fl oz
UX-12	3	1/2"	12,5	100	21.13	250	3626	1000	14504	1000	14504	1000	14504	1,7	.0575

The indicated pressure ratings only apply to the coupling itself and depend on the connection type.

UX

Flow Characteristics

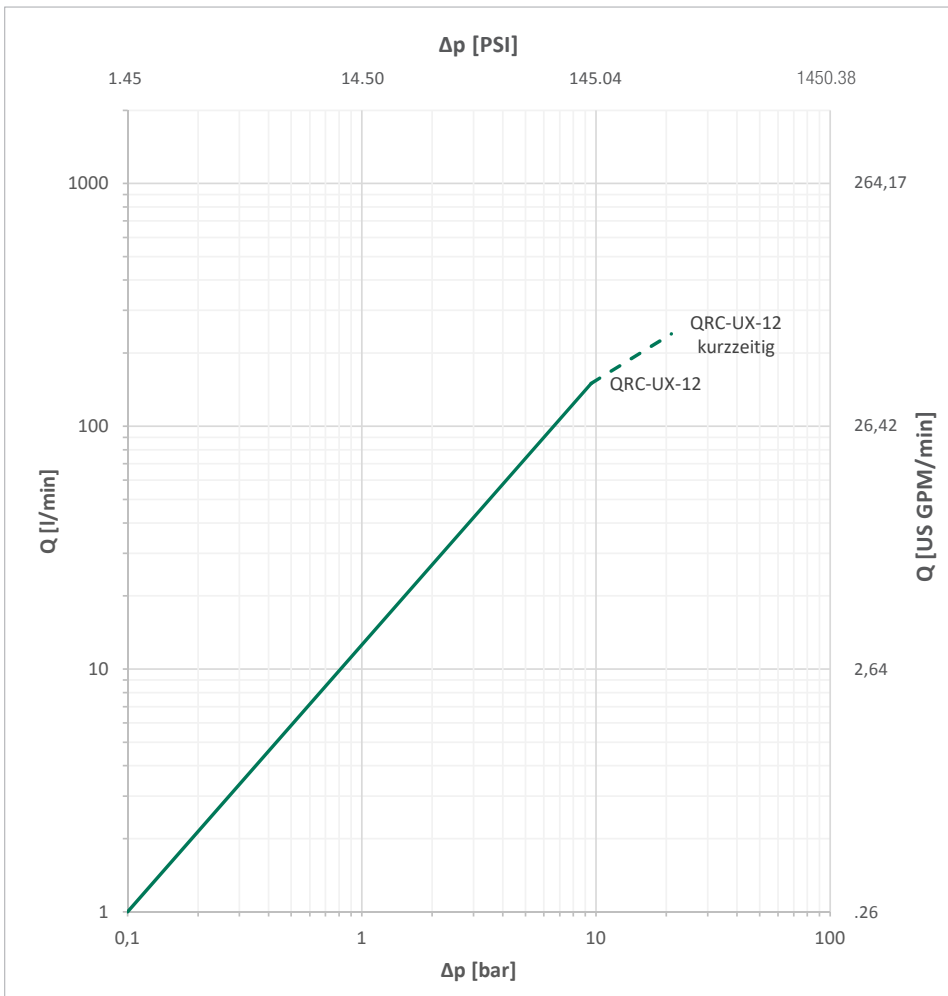



Please note: Unless otherwise stated, all flow characteristics have been determined with hydraulic oil with a kinematic viscosity of 28,8 - 35,2 mm²/s (28,8 - 35,2 cSt) and are only valid for components with non-reducing connections.

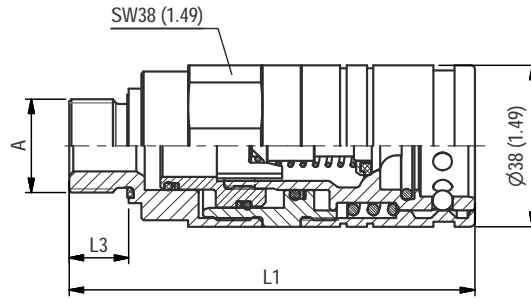

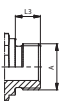

SW: Width across flats. All dimensions in mm (inch).

Series UX-S-10 ▪ BG 3 ▪ Nominal Size 12,5
UX

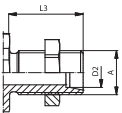
Port A	Dimensions (^{mm} / _{in})				Female Body		Weight (^{kg} / _{lbs}) ca. per 100	
	ØD2	L1	L2	L3	L4	Old Part Numbers STAUFF Ordering Codes		
Male Thread according to EN ISO 9974-2, DIN 3852 T11 Shape E								
	M22x1,5	95,5		14		UX10-1-AME22S	49,50	
		3,76		.55		QRC-UX-S-12-F-M22MWD-S1-W66-SM	109,13	
Male Thread according to ISO 6149, DIN 3852 T3, Shape C								
	M22x1,5	94		13		UX10-1-AMF22S	49,20	
		3,70		.51		QRC-UX-S-12-F-M22MOR-S1-W66-SM	108,47	
Male Thread with 24° Conical Bore - Bulkhead - Shape W according to DIN 3861								
	M18x1,5	12L	112,5		30	UX10-1-N1218S	50,20	
			4,43		1,18		QRC-UX-S-12-F-12LB-S1-W66	110,67
	M22x1,5	15L	109,5		27		UX10-1-N1522S	51,30
			4,31		1,06		QRC-UX-S-12-F-15LB-S1-W66	113,10
	M26x1,5	18L	109,5		27		UX10-1-N1826S	52,70
			4,31		1,06		QRC-UX-S-12-F-18LB-S1-W66	116,18

Dust Cover Clips: Please see page 188.

Note: The connection of the two halves of a coupling is achieved depending on the type. It is important to observe the positive engagement of plug-type couplings and the secure tightening of screw-type couplings to the limit stop of the thread. Forced or improper separation will result in malfunction of the coupling.



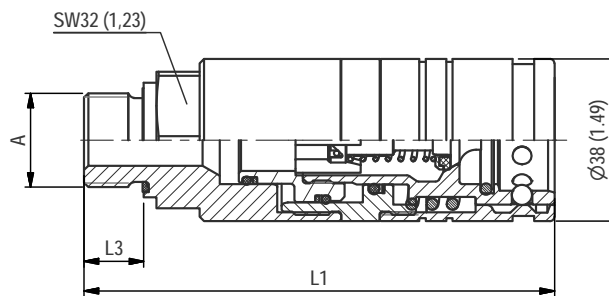

SW: Width across flats. All dimensions in mm (inch).

Series UX-L-10 • BG 3 • Nominal Size 12,5

UX

Port A	Dimensions (^{mm} / _{in})				Female Body		Weight (^{kg} / _{lbs}) ca. per 100		
	ØD2	L1	L2	L3	L4	Old Part Numbers STAUFF Ordering Codes			
Male Thread according to EN ISO 9974-2, DIN 3852 T11 Shape E									
	M22x1,5	110,3		14		UX10-1-AME22L	59,60		
		4.34		.55		QRC-UX-L-12-F-M22MWD-S1-W66-SM	131.40		
Male Thread according to ISO 6149, DIN 3852 T3, Shape C									
	M18x1,5	110,8		14		UX10-1-AMF18L	61,90		
		4.36		.55		QRC-UX-L-12-F-M18MOR-S1-W66-SM	136.47		
	M22 x 1,5	110,8		14		UX10-1-AMF22L	59,60		
		4.36		.55		QRC-UX-L-12-F-M22MOR-S1-W66-SM	131.40		
Male Thread with 24° Conical Bore - Bulkhead - Shape W according to DIN 3861									
	M18x1,5	12L	121,5		26	UX10-1-N1218L	60,20		
			4.78		1.02		QRC-UX-L-12-F-12LB-S1-W66	132.72	
	M22 x 1,5	15L	123,5		26	UX10-1-N1522L	62,90		
			4.86		1.02		QRC-UX-L-12-F-15LB-S1-W66	138.67	
Female Thread according to ISO 1179 - ANSI B 1.20.3 - SAE J1926-1									
	G1/2"		107,3			15	UX10-1-IGF08L	60,40	
			4.22				.59	QRC-UX-L-12-F-G08-S1-W66	133.16
	NPTF 1/2"-14		107,3					UX10-1-INF08L	60,80
			4.22					QRC-UX-L-12-F-NF08-S1-W66	134.04
	UNF 3/4"-16		107,3			14	UX10-1-UNF08L	60,90	
			4.22			.55	QRC-UX-L-12-F-U08-S1-W66	134.26	
Banjo screw for banjos according to DIN 7643									
M22x1,5	18	134,8		39	14	UX10-1-X0001L	61,20		
		5.31		1.54	.55	QRC-UX-L-12-F-BS22-S1-W66	134.92		

Dust Cover Clips: Please see page 188.

Note: The connection of the two halves of a coupling is achieved depending on the type. It is important to observe the positive engagement of plug-type couplings and the secure tightening of screw-type couplings to the limit stop of the thread. Forced or improper separation will result in malfunction of the coupling.



Series IA - Carbon Steel

Series IA - Overview	58	Series IA-38 - BG 12 - Nominal Size 38	61
Series IA-06 - BG 1 - Nominal Size 6,3	59	Series IA-51 - BG 14 - Nominal Size 51	61
Series IA-10 - BG 2 - Nominal Size 10	59	Series IA - Dust Protection	62
Series IA-12 - BG 3 - Nominal Size 12,5	60		
Series IA-19 - BG 6 - Nominal Size 19	60		
Series IA-25 - BG 8 - Nominal Size 25	61		
Series IA-31 - BG 10 - Nominal Size 31,5	61		

IA



Series IA - Carbon Steel

Material	Carbon Steel
Surface Finishing	Zinc-Nickel
Standard Seal Material(s)	NBR (Buna-N®) ²
Working Temperature	-25° C ... +100° C / -13° F ... +212° F
Valve Design	Poppet Valve
Connection	Push and actuate Push Sleeve
Disconnection	Actuate Push Sleeve
Connect Under Pressure	not allowed
Application	Agricultural and Forestry Machinery
ISO Interchange	ISO 7241-1, Series A



²Alternative seal materials are available on request.

Technical Data

Series	BG	DN Zoll Inch	DN metric ISO 4397	Q _{max}		Working Pressure		Bursting Pressure Connected		Female Body		Male Tip		Spillage	
				l/min	US GPM	bar	PSI	bar	PSI	bar	PSI	bar	PSI	ml	fl oz
IA-06	1	1/4"	6,3	17	4.49	350	5076	1400	20305	1700	24656	1500	21756	0,5	.0169
IA-10	2	3/8"	10	46	12.15	275	3989	1500	21756	1500	21756	1400	20305	1,9	.0642
IA-12	3	1/2"	12,5	90	23.77	275	3989	1200	17404	1400	20305	1000	14504	2,7	.0913
IA-19	6	3/4"	19 (20)	190	50.19	200	2901	1000	14504	1500	21756	900	13053	9,3	.3145
IA-25	8	1"	25	280	73.97	200	2901	1000	14504	1000	14504	1300	18855	16,0	.5410
IA-31	10	1 1/4"	31	480	126.80	200	2901	1000	14504	850	12328	1100	15954	30,0	1.0144
IA-38	12	1 1/2"	38	757	199.98	130	1885	820	11893	800	11603	800	11603	54,0	1.8260
IA-51	14	2"	51	1000	264.17	130	1885	1000	14504	960	13924	650	9427	120,0	4.0577

The indicated pressure ratings only apply to the coupling itself and depend on the connection type.

Flow Characteristics

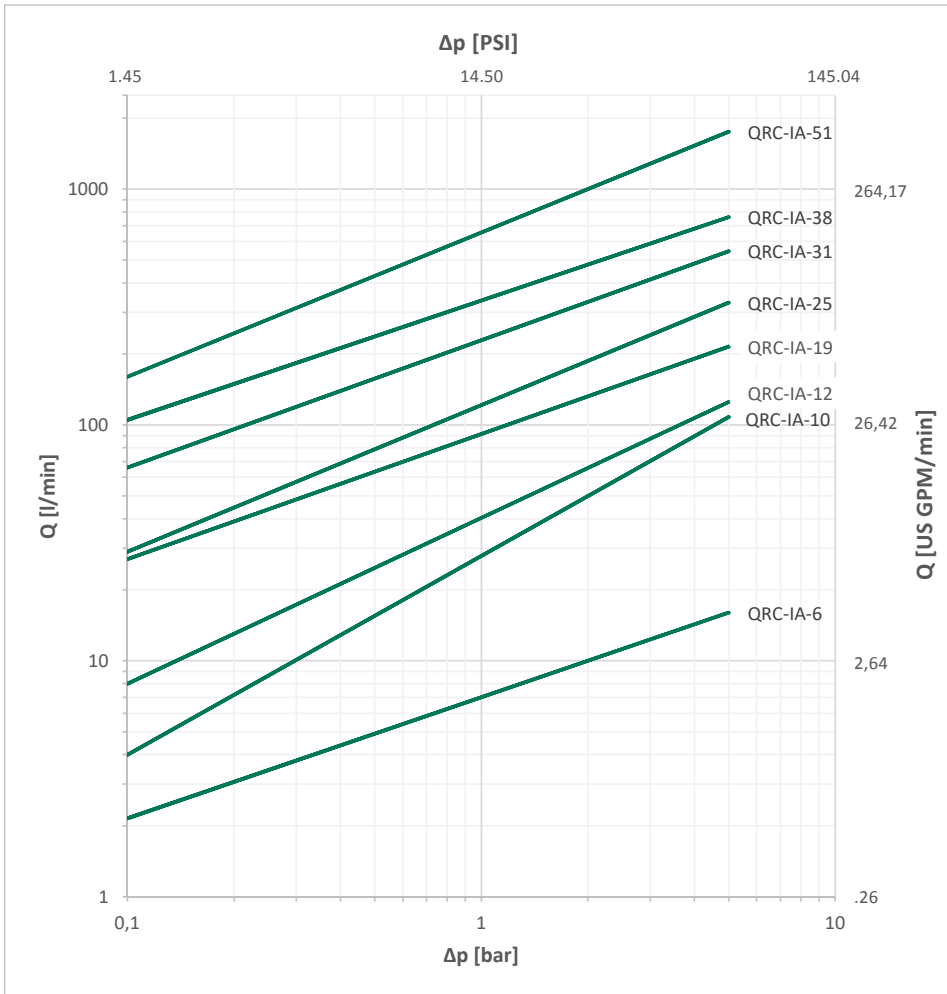

Please note: Unless otherwise stated, all flow characteristics have been determined with hydraulic oil with a kinematic viscosity of 28,8 - 35,2 mm²/s (28,8 - 35,2 cSt) and are only valid for components with non-reducing connections.



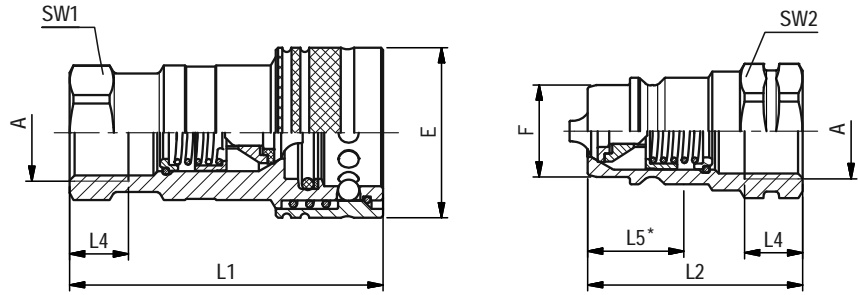

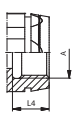
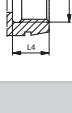
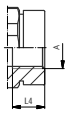

SW: Width across flats. All dimensions in mm (inch). Drawing similar Series IA-12.
* Insertion Male Tip.

Series IA-06 • BG 1 • Nominal Size 6,3

Port A	Dimensions (^{mm} / _{in})								Female Body		Weight (^{kg} / _{lbs}) ca. per 100	Male Tip		Weight (^{kg} / _{lbs}) ca. per 100
	ØE	ØF	L1	L2	L4 min	L5	SW1	SW2	Old Part Numbers	STAUFF Ordering Codes		Old Part Numbers	STAUFF Ordering Codes	
Female Thread according to DIN 3852 - ANSI B 1.20.3														
 G1/4"	26	11,85	49,2	35	12	13,7	19	19	IA06-1-IGF04	10,60	IA06-2-IGF04	3,70		
	1.02	.47	1.94	1.38	.47	.54	.75	.75	QRC-IA-06-F-G04-BT-W3	23.37	QRC-IA-06-M-G04-B-W3	8.16		
 NPTF 1/4" -18	26	11,85	49,2	35		13,7	19	19	IA06-1-INF04	10,70	IA06-2-INF04	3,80		
	1.02	.47	1.94	1.38		.54	.75	.75	QRC-IA-06-F-NF04-BT-W3	23.59	QRC-IA-06-M-NF04-B-W3	8.38		
Female Thread according to SAE J 1926-1														
 UNF 9/16" -18	26	11,85	49,2	35	12,7	13,7	19	19	IA06-1-IUF06	10,20	IA06-2-IUF06	3,40		
	1.02	.47	1.94	1.38	.50	.54	.75	.75	QRC-IA-06-F-U06-BT-W3	22.49	QRC-IA-06-M-U06-B-W3	7.50		

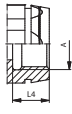
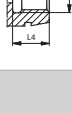
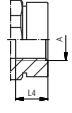
Series IA-10 • BG 2 • Nominal Size 10

Port A	Dimensions (^{mm} / _{in})								Female Body		Weight (^{kg} / _{lbs}) ca. per 100	Male Tip		Weight (^{kg} / _{lbs}) ca. per 100
	ØE	ØF	L1	L2	L4 min	L5	SW1	SW2	Old Part Numbers	STAUFF Ordering Codes		Old Part Numbers	STAUFF Ordering Codes	
Female Thread according to DIN 3852 - ANSI B 1.20.3														
 G 3/8"	30	17,3	60,5	42,5	12	18	22	22	IA10-1-IGF06	15,50	IA10-2-IGF06	5,90		
	1.18	.68	2.38	1.67	.47	.71	.87	.87	QRC-IA-10-F-G06-BT-W3	34.17	QRC-IA-10-M-G06-B-W3	13.01		
 NPTF 3/8" -18	30	17,3	60,5	42,5		18	22	22	IA10-1-INF06	15,60	IA10-2-INF06	6		
	1.18	.68	2.38	1.67		.71	.87	.87	QRC-IA-10-F-NF06-BT-W3	34.39	QRC-IA-10-M-NF06-B-W3	13.23		
Female Thread according to SAE J 1926-1														
 UNF 9/16" -18	30	17,3	60,5	42,5	12,7	18	22	22	IA10-1-IUF06	17,50	IA10-2-IUF06	7,90		
	1.18	.68	2.38	1.67	.50	.71	.87	.87	QRC-IA-10-F-U06-BT-W3	38.58	QRC-IA-10-M-U06-B-W3	17.42		
 UNF 3/4" -16	30	17,3	60,5	42,5	14,3	18	22	22	IA10-1-IUF08	18,40	IA10-2-IUF08	6,30		
	1.18	.68	2.38	1.67	.56	.71	.87	.87	QRC-IA-10-F-U08-BT-W3	40.57	QRC-IA-10-M-U08-B-W3	13.89		

Note: The connection of the two halves of a coupling is achieved depending on the type. It is important to observe the positive engagement of plug-type couplings and the secure tightening of screw-type couplings to the limit stop of the thread. Forced or improper separation will result in malfunction of the coupling.



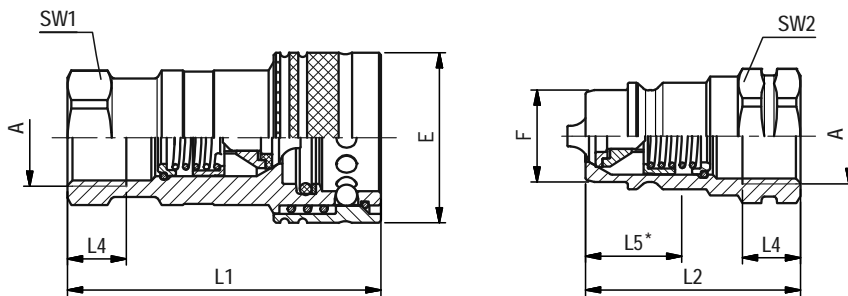

SW: Width across flats. All dimensions in mm (inch). Drawing similar Series IA-12.
* Insertion Male Tip.

Series IA-12 • BG 3 • Nominal Size 12,5

Port A	Dimensions (^{mm} / _{in})								Female Body		Weight (^{kg} / _{lbs}) ca. per 100	Male Tip		Weight (^{kg} / _{lbs}) ca. per 100
	ØE	ØF	L1	L2	L4 min	L5	SW1	SW2	Old Part Numbers	STAUFF Ordering Codes		Old Part Numbers	STAUFF Ordering Codes	
Female Thread according to DIN 3852 - ANSI B 1.20.3 - ISO 9974-1														
	G 1/2"	38	20,55	70	48	14	21,5	27	27	IA12-1-IGF08	26,80	IA12-2-IGF08	9,70	
		1.5	.81	2.76	1.89	.55	.85	1.06	1.06	QRC-IA-12-F-G08-BT-W3	59.08	QRC-IA-12-M-G08-B-W3	21.38	
	NPTF 1/2" -14	38	20,55	70	48		21,5	27	27	IA12-1-INF08	26,90	IA12-2-INF08	9,80	
		1.5	.81	2.76	1.89		.85	1.06	1.06	QRC-IA-12-F-NF08-BT-W3	59.30	QRC-IA-12-M-NF08-B-W3	21.61	
	NPTF 3/4" -14	38	20,55	70	48		21,5	27	27	IA12-1-INF12	35,30	IA12-2-INF12	9,80	
		1.5	.81	2.76	1.89		.85	1.06	1.06	QRC-IA-12-F-NF12-BT-W3	77.82	QRC-IA-12-M-NF12-B-W3	21.61	
Female Thread according to SAE J 1926-1														
	M22x1,5	38	20,55	70	48	15,5	21,5	27	27	IA12-1-IMF22	26	IA12-2-IMF22	9	
		1.5	.81	2.76	1.89	.61	.85	1.06	1.06	QRC-IA-12-F-M22-BT-W3	57.32	QRC-IA-12-M-M22-B-W3	19.84	
	UNF 3/4" -16	38	20,55	70	48	14,3	21,5	27	27	IA12-1-IUF08	27,40	IA12-2-IUF08	10,10	
		1.5	.81	2.76	1.89	.56	.85	1.06	1.06	QRC-IA-12-F-U08-BT-W3	60.41	QRC-IA-12-M-U08-B-W3	22.27	
	UNF 7/8" -14	38	20,55	70	48	16,7	21,5	27	27	IA12-1-IUF10	26	IA12-2-IUF10	10,10	
		1.5	.81	2.76	1.89	.66	.85	1.06	1.06	QRC-IA-12-F-U10-BT-W3	57.32	QRC-IA-12-M-U10-B-W3	22.27	

Series IA-19 • BG 6 • Nominal Size 19

Port A	Dimensions (^{mm} / _{in})								Female Body		Weight (^{kg} / _{lbs}) ca. per 100	Male Tip		Weight (^{kg} / _{lbs}) ca. per 100
	ØE	ØF	L1	L2	L4 min	L5	SW1	SW2	Old Part Numbers	STAUFF Ordering Codes		Old Part Numbers	STAUFF Ordering Codes	
Female Thread according to DIN 3852 - ANSI B 1.20.3														
	G 3/4"	45	29,1	84,3	57	16	26,8	34	34	IA19-1-IGF12	42,80	IA19-2-IGF12	18	
		1.77	1.14	3.32	2.24	.63	1.05	1.34	1.34	QRC-IA-19-F-G12-BT-W3	94.36	QRC-IA-19-M-G12-B-W3	39.68	
	NPTF 3/4" -14	45	29,1	84,3	57		26,8	34	34	IA19-1-INF12	43,40	IA19-2-INF12	18,60	
		1.77	1.14	3.32	2.24		1.05	1.34	1.34	QRC-IA-19-F-NF12-BT-W3	95.68	QRC-IA-19-M-NF12-B-W3	41.01	

Note: The connection of the two halves of a coupling is achieved depending on the type. It is important to observe the positive engagement of plug-type couplings and the secure tightening of screw-type couplings to the limit stop of the thread. Forced or improper separation will result in malfunction of the coupling.



Series IA-25 ▪ BG 8 ▪ Nominal Size 25

Port A	Dimensions (mm/in)									Female Body		Weight (^{kg} /lbs) ca. per 100	Male Tip		Weight (^{kg} /lbs) ca. per 100
	ØE	ØF	L1	L2	L4 min	L5	SW1	SW2	Old Part Numbers	STAUFF Ordering Codes	Old Part Numbers		STAUFF Ordering Codes		
	Female Thread according to DIN 3852 - ANSI B 1.20.3														
	G 1"	52	34,35	101	67,5	18	33	41	41	IA25-1-IGF16	70	IA25-2-IGF16	30,40		
		2.05	1.35	3.98	2.66	.71	1.3	1.61	1.61	QRC-IA-25-F-G16-BT-W3	154.32	QRC-IA-25-M-G16-B-W3	67.02		
	NPTF 1" -11 1/2	52	34,35	101	67,5		33	41	41	IA25-1-INF16	70,80	IA25-2-INF16	31,30		
		2.05	1.35	3.98	2.66		1.3	1.61	1.61	QRC-IA-25-F-NF16-BT-W3	156.09	QRC-IA-25-M-NF16-B-W3	69.00		

Series IA-31 ▪ BG 10 ▪ Nominal Size 31,5

Port A	Dimensions (mm/in)									Female Body		Weight (^{kg} /lbs) ca. per 100	Female Body with Dust Plug		Weight (^{kg} /lbs) ca. per 100
	ØE	ØF	L1	L2	L4 min	L5	SW1	SW2	Old Part Numbers	STAUFF Ordering Codes	Old Part Numbers		STAUFF Ordering Codes		
	Female Thread according to DIN 3852 - ANSI B 1.20.3														
	G 1 1/4"	70	45	116,9	75	20	41,3	50	50	IA31-1-IGF20	151,50	IA31-2-IGF20	55,90		
		2.75	1.77	4.60	2.95	.79	1.62	1.97	1.97	QRC-IA-31-F-G20-BT-W3	334	QRC-IA-31-M-G20-B-W3	123.24		
	NPTF 1 1/4" -11 1/2	70	45	116,9	75		41,3	50	50	IA31-1-INF20	153,20	IA31-2-INF20	57,20		
		2.75	1.77	4.60	2.95		1.62	1.97	1.97	QRC-IA-31-F-NF20-BT-W3	337.75	QRC-IA-31-M-NF20-B-W3	126.10		

Series IA-38 ▪ BG 12 ▪ Nominal Size 38

Port A	Dimensions (mm/in)									Female Body		Weight (^{kg} /lbs) ca. per 100	Male Tip		Weight (^{kg} /lbs) ca. per 100
	ØE	ØF	L1	L2	L4 min	L5	SW1	SW2	Old Part Numbers	STAUFF Ordering Codes	Old Part Numbers		STAUFF Ordering Codes		
	Female Thread according to DIN 3852 - ANSI B 1.20.3														
	G 1 1/2"	82	55	133	83,5	22	48,8	60	60	IA38-1-IGF24	244,50	IA38-2-IGF24	91,80		
		3.23	2.16	5.24	3.29	.87	1.92	2.36	2.36	QRC-IA-38-F-G24-BT-W3	539.03	QRC-IA-38-M-G24-B-W3	202.38		
	NPTF 1 1/2" -11 1/2	82	55	133	83,5		48,8	60	60	IA38-1-INF24	246,40	IA38-2-INF24	93,80		
		3.23	2.16	5.24	3.29		1.92	2.36	2.36	QRC-IA-38-F-NF24-BT-W3	543.22	QRC-IA-38-M-NF24-B-W3	206.79		

Series IA-51 ▪ BG 14 ▪ Nominal Size 51

Port A	Dimensions (mm/in)									Female Body		Weight (^{kg} /lbs) ca. per 100	Female Body mit Dust Plug		Weight (^{kg} /lbs) ca. per 100
	ØE	ØF	L1	L2	L4 min	L5	SW1	SW2	Old Part Numbers	STAUFF Ordering Codes	Old Part Numbers		STAUFF Ordering Codes		
	Female Thread according to DIN 3852 - ANSI B 1.20.3														
	G 2"	99	65,1	169	108	24	60	75	75	IA51-1-IGF32	500	IA51-2-IGF32	180,40		
		3.89	2.56	6.65	4.25	.94	2.36	2.95	2.95	QRC-IA-51-F-G32-BT-W3	1102.31	QRC-IA-51-M-G32-B-W3	397.71		
	NPTF 2" -11 1/2	99	65,1	169	108		60	75	75	IA51-1-INF32	501	IA51-2-INF32	182		
		3.89	2.56	6.65	4.25		2.36	2.95	2.95	QRC-IA-51-F-NF32-BT-W3	1104.52	QRC-IA-51-M-NF32-B-W3	401.24		

Note: The connection of the two halves of a coupling is achieved depending on the type. It is important to observe the positive engagement of plug-type couplings and the secure tightening of screw-type couplings to the limit stop of the thread. Forced or improper separation will result in malfunction of the coupling.



Series IA - Dust Protection

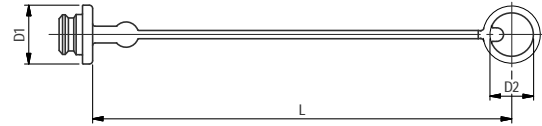
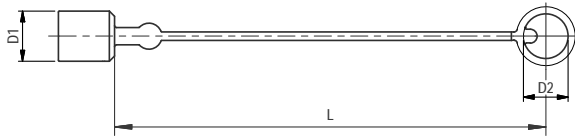

Dimensions (mm/in)			Material	Dust Cap for Male Tip	
D1	D2	L		Old Part Numbers	STAUFF Ordering Codes
11	6	110	Plastic (Colour: Red)	IA06-0-RT001	QRC-IA-06-DM-6-KI-RD
.43	.24	4.33			
24	22	220	Plastic (Colour: Red)	IA10-0-RT001	QRC-IA-10-DM-22-KI-RD
.93	.87	8.66			
29	26	250	Plastic (Colour: Red)	IA12-0-RT001	QRC-IA-12-DM-26-KI-RD
1.14	1.02	9.84			
36,5	36	270	Plastic (Colour: Red)	IA19-0-RT001	QRC-IA-19-DM-36-KI-RD
1.44	1.42	10.63			
36	28	235	Plastic (Colour: Red)	IA25-0-RT001	QRC-IA-25-DM-28-KI-RD
1.42	1.10	9.25			

Dimensions (mm/in)			Material	Dust Plug for Female Body	
D1	D2	L		Old Part Numbers	STAUFF Ordering Codes
10	6	110	Plastic (Colour: Red)	IA06-9-RT001	QRC-IA-06-DF-6-KI-RD
.39	.24	4.33			
28	22	220	Plastic (Colour: Red)	IA10-9-RT001	QRC-IA-10-DF-22-KI-RD
1.10	.87	8.66			
35	26	250	Plastic (Colour: Red)	IA12-9-RT001	QRC-IA-12-DF-26-KI-RD
1.38	1.02	9.84			
42	36	270	Plastic (Colour: Red)	IA19-9-RT001	QRC-IA-19-DF-36-KI-RD
1.65	1.42	10.63			
41	28	235	Plastic (Colour: Red)	IA25-9-RT001	QRC-IA-25-DF-28-KI-RD
1.61	1.10	9.25			

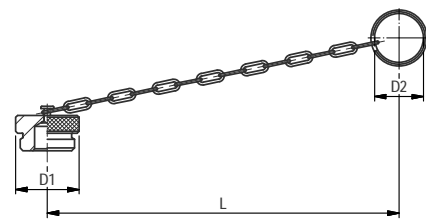
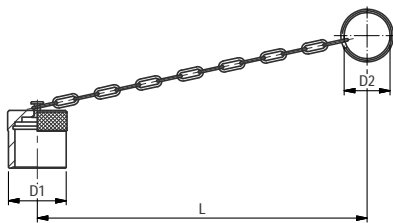

Dimensions (mm/in)			Material	Dust Cap for Male Tip	
D1	D2	L		Old Part Numbers	STAUFF Ordering Codes
19	30	180	Aluminium with chain	IA06-0-SI001	QRC-IA-06-DM-30/CN-W89-SI
.75	1.18	7.09			
30	33	200	Aluminium with chain	IA10-0-SI001	QRC-IA-10-DM-33/CN-W89-SI
1.18	1.30	7.87			
38	32	205	Aluminium with chain	IA12-0-SI001	QRC-IA-12-DM-32/CN-W89-SI
1.50	1.26	8.07			
45	47	275	Aluminium with chain	IA19-0-SI001	QRC-IA-19-DM-47/CN-W89-SI
1.77	1.85	10.83			
45	41	290	Aluminium with chain	IA25-0-SI001	QRC-IA-25-DM-41/CN-W89-SI
1.77	1.61	11.42			
70	47	275	Aluminium with chain	IA31-0-SI001	QRC-IA-31-DM-47/CN-W89-SI
2.76	1.85	10.83			

Dimensions (mm/in)			Material	Dust Plug for Female Body	
D1	D2	L		Old Part Numbers	STAUFF Ordering Codes
19	30	160	Aluminium with chain	IA06-9-SI001	QRC-IA-06-DF-30/CN-W89-SI
.75	1.18	6.30			
30	33	200	Aluminium with chain	IA10-9-SI001	QRC-IA-10-DF-33/CN-W89-SI
1.18	1.30	7.87			
38	32	205	Aluminium with chain	IA12-9-SI001	QRC-IA-12-DF-32/CN-W89-SI
1.50	1.26	8.07			
45	47	275	Aluminium with chain	IA19-9-SI001	QRC-IA-19-DF-47/CN-W89-SI
1.77	1.85	10.83			
43	41	240	Aluminium with chain	IA25-9-SI001	QRC-IA-25-DF-41/CN-W89-SI
1.69	1.61	9.45			
70	47	275	Aluminium with chain	IA31-9-SI001	QRC-IA-31-DF-47/CN-W89-SI
2.76	1.85	10.83			

In addition to the standard colours as stated above, plastic dust caps are also available in blue, green, yellow and black. Please use the old color codes BL, GN, GE and SW respectively instead of RT. Please use the STAUFF codes BU, GN, YE and BK respectively instead of RD.



Series IA - Stainless Steel

Series IA - Overview	64	Series IA-38 - BG 12 - Nominal Size 38	66
Series IA-06 - BG 1 - Nominal Size 6,3	65	Series IA-51 - BG 14 - Nominal Size 51	66
Series IA-10 - BG 2 - Nominal Size 10	65	Series IA - Dust Protection	67
Series IA-12 - BG 3 - Nominal Size 12,5	65		
Series IA-19 - BG 6 - Nominal Size 19	65		
Series IA-25 - BG 8 - Nominal Size 25	66		
Series IA-31 - BG 10 - Nominal Size 31,5	66		

IA



Series IA - Stainless Steel

Material	Stainless Steel V4A (AISI 316)
Surface Finishing	-
Standard Seal Material(s)	FKM (Viton®) ²
Working Temperature	-25° C ... +200° C / -13° F ... +392° F
Valve Design	Poppet Valve
Connection	Push and actuate Push Sleeve
Disconnection	Actuate Push Sleeve
Connect Under Pressure	not allowed
Application	Agricultural and Forestry Machinery, Industrial Hydraulic
ISO Interchange	ISO 7241-1, Series A



² Alternative seal materials are available on request.

Technical Data

Series	BG	DN Zoll Inch	DN metric ISO 4397	Q _{max}		Working Pressure		Bursting Pressure Connected		Female Body		Male Tip		Spillage	
				l/min	US GPM	bar	PSI	bar	PSI	bar	PSI	bar	PSI	ml	fl oz
IA-06	1	1/4"	6,3	17	4.49	450	6527	2900	42061	2900	42061	3200	46412	0,5	.0169
IA-10	2	3/8"	10	46	12.15	300	4351	1300	18855	1250	18130	1250	18130	1,9	.0642
IA-12	3	1/2"	12,5	90	23.77	300	4351	1350	19580	1200	17404	1200	17404	2,7	.0913
IA-19	6	3/4"	19 (20)	190	50.19	250	3626	1100	15954	1000	14504	800	11603	9,3	.3145
IA-25	8	1"	25	280	73.97	200	2901	850	12328	650	9427	600	8702	19,0	.6425
IA-31	10	1 1/4"	31	480	126.80	100	1450	400	5801	400	5801	400	5801	30,0	1.0144
IA-38	12	1 1/2"	38	700	184.92	80	1160	320	4641	320	4641	320	4641	54,0	1.8260
IA-51	14	2"	51	1000	264.17	60	870	250	3626	250	3626	250	3626	120,0	4.0577

The indicated pressure ratings only apply to the coupling itself and depend on the connection type.

Flow Characteristics

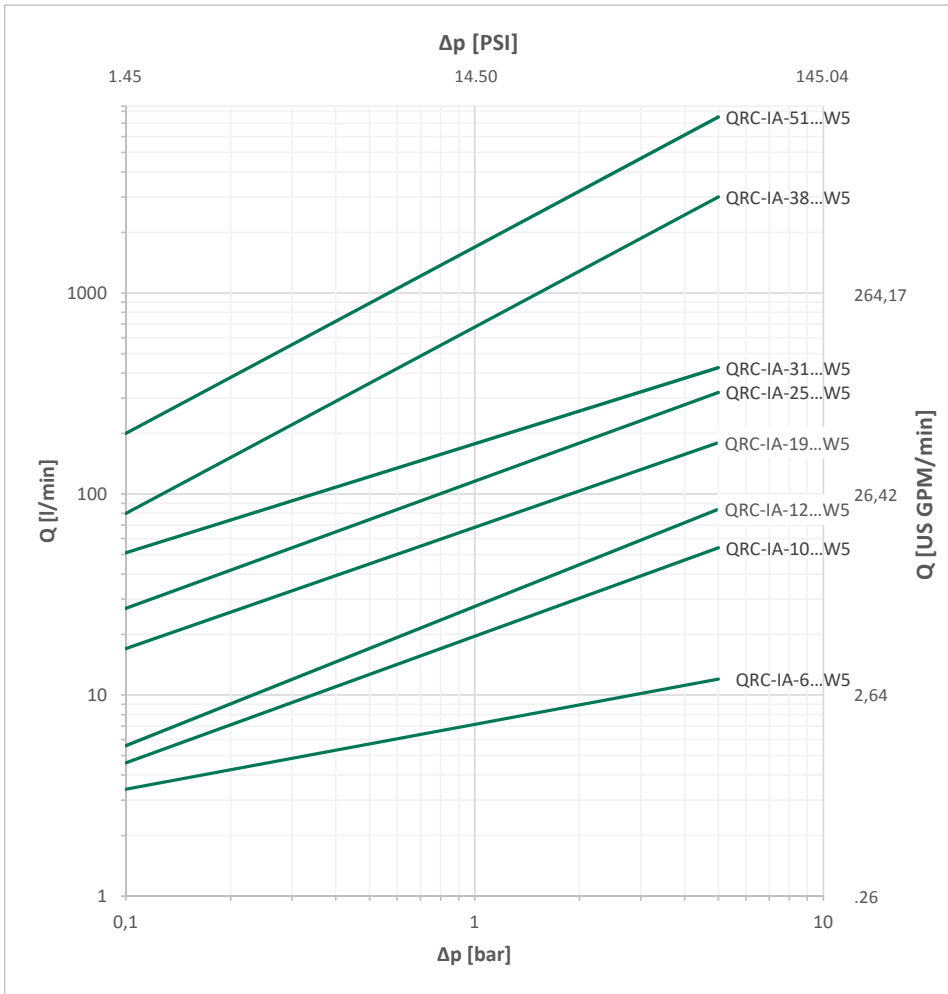

Please note: Unless otherwise stated, all flow characteristics have been determined with hydraulic oil with a kinematic viscosity of 28,8 - 35,2 mm²/s (28,8 - 35,2 cSt) and are only valid for components with non-reducing connections.



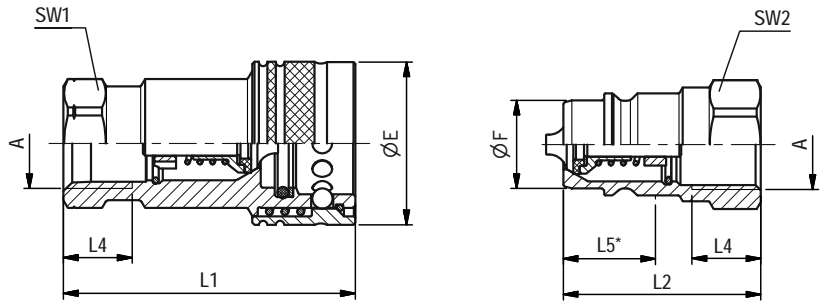

SW: Width across flats. All dimensions in mm (inch). Drawing similar Series IA-12.
* Insertion Male Tip.

Series IA-06 • BG 1 • Nominal Size 6,3

Port A	Dimensions (^{mm} / _{in})								Female Body		Weight	Male Tip		Weight
	ØE	ØF	L1	L2	L4 min	L5	SW1	SW2	Old Part Numbers	(^{kg} / _{lbs}) ca.	Old Part Numbers	(^{kg} / _{lbs}) ca.		
									STAUFF Ordering Codes	per 100	STAUFF Ordering Codes	per 100		
Female Thread according to DIN 3852 - ANSI B. 1.20.3														
	G 1/4"	26	11,85	50,5	35,5	12	14,5	19	19	IA06-1-IGF04-VA	11,90	IA06-2-IGF04-VA	3,80	
		1.02	.47	1.99	1.40	.47	.57	.75	.75	QRC-IA-06-F-G04-VT-W5	26.24	QRC-IA-06-M-G04-V-W5	8.38	
	NPTF 1/4" -18	26	11,85	50,5	35,5		14,5	19	19	IA06-1-INF04-VA	12	IA06-2-INF04-VA	3,90	
		1.02	.47	1.99	1.40		.57	.75	.75	QRC-IA-06-F-NF04-VT-W5	26.46	QRC-IA-06-M-NF04-V-W5	8.60	

Series IA-10 • BG 2 • Nominal Size 10

Port A	Dimensions (^{mm} / _{in})								Female Body		Weight	Male Tip		Weight
	ØE	ØF	L1	L2	L4 min	L5	SW1	SW2	Old Part Numbers	(^{kg} / _{lbs}) ca.	Old Part Numbers	(^{kg} / _{lbs}) ca.		
									STAUFF Ordering Codes	per 100	STAUFF Ordering Codes	per 100		
Female Thread according to DIN 3852 - ANSI B. 1.20.3														
	G 3/8"	30	17,3	58,5	40,5	12	17	22	22	IA10-1-IGF06-VA	15,70	IA10-2-IGF06-VA	5,90	
		1.18	.68	2.30	1.59	.47	.62	.87	.87	QRC-IA-10-F-G06-VT-W5	34.61	QRC-IA-10-M-G06-V-W5	13.01	
	NPTF 3/8" -18	30	17,3	58,5	40,5		17	22	22	IA10-1-INF06-VA	15,80	IA10-2-INF06-VA	6	
		1.18	.68	2.30	1.59		.62	.87	.87	QRC-IA-10-F-NF06-VT-W5	34.83	QRC-IA-10-M-NF06-V-W5	13.23	

Series IA-12 • BG 3 • Nominal Size 12,5

Port A	Dimensions (^{mm} / _{in})								Female Body		Weight	Male Tip		Weight
	ØE	ØF	L1	L2	L4 min	L5	SW1	SW2	Old Part Numbers	(^{kg} / _{lbs}) ca.	Old Part Numbers	(^{kg} / _{lbs}) ca.		
									STAUFF Ordering Codes	per 100	STAUFF Ordering Codes	per 100		
Female Thread according to DIN 3852 - ANSI B. 1.20.3														
	G 1/2"	37,9	20,55	68	46	14	21,5	27	27	IA12-1-IGF08-VA	29,50	IA12-2-IGF08-VA	9,70	
		1.49	.81	2.68	1.81	.55	.85	1.06	1.06	QRC-IA-12-F-G08-VT-W5	65.04	QRC-IA-12-M-G08-V-W5	21.38	
	NPTF 1/2" -14	37,9	20,55	68	46		21,5	27	27	IA12-1-INF08-VA	29,70	IA12-2-INF08-VA	9,90	
		1.49	.81	2.68	1.81		.85	1.06	1.06	QRC-IA-12-F-NF08-VT-W5	65.48	QRC-IA-12-M-NF08-V-W5	21.83	

Series IA-19 • BG 6 • Nominal Size 19

Port A	Dimensions (^{mm} / _{in})								Female Body		Weight	Male Tip		Weight
	ØE	ØF	L1	L2	L4 min	L5	SW1	SW2	Old Part Numbers	(^{kg} / _{lbs}) ca.	Old Part Numbers	(^{kg} / _{lbs}) ca.		
									STAUFF Ordering Codes	per 100	STAUFF Ordering Codes	per 100		
Female Thread according to DIN 3852 - ANSI B. 1.20.3														
	G 3/4"	45	29,1	84,3	57	16	20,8	34	34	IA19-1-IGF12-VA	51	IA19-2-IGF12-VA	16,50	
		1.77	1.14	84	2.24	.63	.82	1.34	1.34	QRC-IA-19-F-G12-VT-W5	112.44	QRC-IA-19-M-G12-V-W5	36.38	
	NPTF 3/4" -14	45	29,1	84,3	57		20,8	34	34	IA19-1-INF12-VA	51,30	IA19-2-INF12-VA	16,80	
		1.77	1.14	3.32	2.24		.82	1.34	1.34	QRC-IA-19-F-NF12-VT-W5	113.10	QRC-IA-19-M-NF12-V-W5	37.04	

Note: The connection of the two halves of a coupling is achieved depending on the type. It is important to observe the positive engagement of plug-type couplings and the secure tightening of screw-type couplings to the limit stop of the thread. Forced or improper separation will result in malfunction of the coupling.



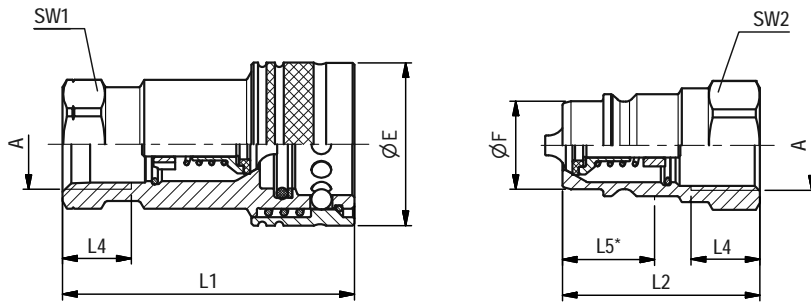

SW: Width across flats. All dimensions in mm (inch). Drawing similar Series IA-12.
* Insertion Male Tip.

Series IA-25 ▪ BG 8 ▪ Nominal Size 25

Port A	Dimensions (^{mm} / _{in})								Female Body		Weight (^{kg} / _{lbs}) ca. per 100	Male Tip		Weight (^{kg} / _{lbs}) ca. per 100
	ØE	ØF	L1	L2	L4 min	L5	SW1	SW2	Old Part Numbers	STAUFF Ordering Codes		Old Part Numbers	STAUFF Ordering Codes	
Female Thread according to DIN 3852 - ANSI B. 1.20.3														
G 1"	52	34,35	97	63,5	18	33,5	41	41	IA25-1-IGF16-VA	63,60	IA25-2-IGF16-VA	28,50		
	2,06	1,35	3,82	2,50	,71	1,32	1,61	1,61	QRC-IA-25-F-G16-VT-W5	140,21	QRC-IA-25-M-G16-V-W5	62,83		
NPTF 1" -11 1/2	52	34,35	97	63,5		33,5	41	41	IA25-1-INF16-VA	64,30	IA25-2-INF16-VA	29,20		
	2,06	1,35	3,82	2,50		1,32	1,61	1,61	QRC-IA-25-F-NF16-VT-W5	141,76	QRC-IA-25-M-NF16-V-W5	64,37		

Series IA-31 ▪ BG 10 ▪ Nominal Size 31,5

Port A	Dimensions (^{mm} / _{in})								Female Body		Weight (^{kg} / _{lbs}) ca. per 100	Male Tip		Weight (^{kg} / _{lbs}) ca. per 100
	ØE	ØF	L1	L2	L4 min	L5	SW1	SW2	Old Part Numbers	STAUFF Ordering Codes		Old Part Numbers	STAUFF Ordering Codes	
Female Thread according to DIN 3852 - ANSI B. 1.20.3														
G 1 1/4"	70	45	115	69	20	34	50	50	IA31-1-IGF20-VA	147	IA31-2-IGF20-VA	48		
	2,75	1,77	4,53	2,72	,79	1,34	1,97	1,97	QRC-IA-31-F-G20-VT-W5	324,08	QRC-IA-31-M-G20-V-W5	105,82		
NPTF 1 1/4" -11 1/2	70	45	115	69		34	50	50	IA31-1-INF20-VA	148,50	IA31-2-INF20-VA	49,50		
	2,75	1,77	4,53	2,72		1,34	1,97	1,97	QRC-IA-31-F-NF20-VT-W5	327,39	QRC-IA-31-M-NF20-V-W5	109,13		

Series IA-38 ▪ BG 12 ▪ Nominal Size 38

Port A	Dimensions (^{mm} / _{in})								Female Body		Weight (^{kg} / _{lbs}) ca. per 100	Male Tip		Weight (^{kg} / _{lbs}) ca. per 100
	ØE	ØF	L1	L2	L4 min	L5	SW1	SW2	Old Part Numbers	STAUFF Ordering Codes		Old Part Numbers	STAUFF Ordering Codes	
Female Thread according to DIN 3852 - ANSI B. 1.20.3														
G 1 1/2"	80	55	123	73	22	50	60	60	IA38-1-IGF24-VA	198	IA38-2-IGF24-VA	73,80		
	3,17	2,16	4,84	2,87	,87	1,97	2,36	2,36	QRC-IA-38-F-G24-VT-W5	436,52	QRC-IA-38-M-G24-V-W5	162,70		
NPTF 1 1/2" -11 1/2	80	55	123	73		50	60	60	IA38-1-INF24-VA	202	IA38-2-INF24-VA	87		
	3,17	2,16	4,84	2,87		1,97	2,36	2,36	QRC-IA-38-F-NF24-VT-W5	445,33	QRC-IA-38-M-NF24-V-W5	191,80		

Series IA-51 ▪ BG 14 ▪ Nominal Size 51

Port A	Dimensions (^{mm} / _{in})								Female Body		Weight (^{kg} / _{lbs}) ca. per 100	Male Tip		Weight (^{kg} / _{lbs}) ca. per 100
	ØE	ØF	L1	L2	L4 min	L5	SW1	SW2	Old Part Numbers	STAUFF Ordering Codes		Old Part Numbers	STAUFF Ordering Codes	
Female Thread according to DIN 3852 - ANSI B. 1.20.3														
G 2"	102	65,1	147	90	24	57	70	70	IA51-1-IGF32-VA	349	IA51-2-IGF32-VA	116,80		
	4,01	2,56	5,79	3,54	,94	2,24	2,75	2,75	QRC-IA-51-F-G32-VT-W5	769,41	QRC-IA-51-M-G32-V-W5	257,50		
NPTF 2" -11 1/2	102	65,1	147	90		57	70	70	IA51-1-INF32-VA	350	IA51-2-INF32-VA	117,80		
	4,01	2,56	5,79	3,54		2,24	2,75	2,75	QRC-IA-51-F-NF32-VT-W5	771,62	QRC-IA-51-M-NF32-V-W5	259,70		

Note: The connection of the two halves of a coupling is achieved depending on the type. It is important to observe the positive engagement of plug-type couplings and the secure tightening of screw-type couplings to the limit stop of the thread. Forced or improper separation will result in malfunction of the coupling.

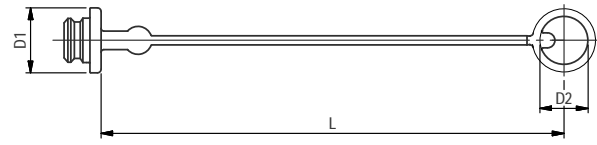
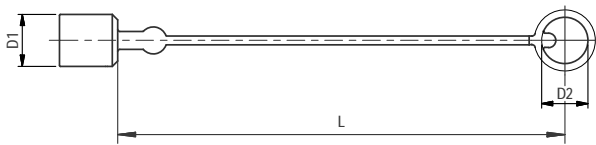

Series IA - Dust Protection

Dimensions (mm/in)			Material	Dust Cap for Male Tip	
D1	D2	L		Old Part Numbers	STAUFF Ordering Codes
11	6	110	Plastic (Colour: Red)	IA06-0-RT001	QRC-IA-06-DM-6-KI-RD
.43	.24	4.33		IA10-0-RT001	QRC-IA-10-DM-22-KI-RD
24	22	220		IA12-0-RT001	QRC-IA-12-DM-26-KI-RD
.93	.87	8.66	Plastic (Colour: Red)	IA19-0-RT001	QRC-IA-19-DM-36-KI-RD
29	26	250		IA25-0-RT001	QRC-IA-25-DM-28-KI-RD
1.14	1.02	9.84		IA25-0-RT001	QRC-IA-25-DM-28-KI-RD
36.5	36	270	Plastic (Colour: Red)	IA06-9-RT001	QRC-IA-06-DF-6-KI-RD
1.44	1.42	10.63		IA10-9-RT001	QRC-IA-10-DF-22-KI-RD
36	28	235		IA12-9-RT001	QRC-IA-12-DF-22-KI-RD
1.42	1.10	9.25	Plastic (Colour: Red)	IA19-9-RT001	QRC-IA-19-DF-36-KI-RD
				IA25-9-RT001	QRC-IA-25-DF-28-KI-RD
				IA25-9-RT001	QRC-IA-25-DF-28-KI-RD

Dimensions (mm/in)			Material	Dust Plug for Female Body	
D1	D2	L		Old Part Numbers	STAUFF Ordering Codes
10	6	110	Plastic (Colour: Red)	IA06-9-RT001	QRC-IA-06-DF-6-KI-RD
.39	.24	4.33		IA10-9-RT001	QRC-IA-10-DF-22-KI-RD
28	22	220		IA12-9-RT001	QRC-IA-12-DF-22-KI-RD
1.10	.87	8.66	Plastic (Colour: Red)	IA19-9-RT001	QRC-IA-19-DF-36-KI-RD
35	26	250		IA25-9-RT001	QRC-IA-25-DF-28-KI-RD
1.38	1.02	9.84		IA25-9-RT001	QRC-IA-25-DF-28-KI-RD
42	36	270	Plastic (Colour: Red)	IA06-9-RT001	QRC-IA-06-DF-6-KI-RD
1.65	1.42	10.63		IA10-9-RT001	QRC-IA-10-DF-22-KI-RD
41	28	235		IA12-9-RT001	QRC-IA-12-DF-22-KI-RD
1.61	1.10	9.25	Plastic (Colour: Red)	IA19-9-RT001	QRC-IA-19-DF-36-KI-RD
				IA25-9-RT001	QRC-IA-25-DF-28-KI-RD
				IA25-9-RT001	QRC-IA-25-DF-28-KI-RD

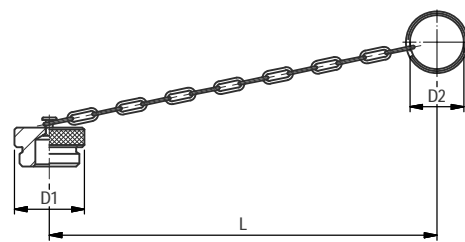
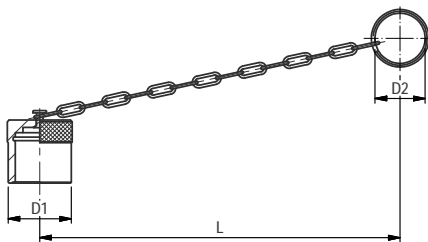

Dimensions (mm/in)			Material	Dust Cap for Male Tip	
D1	D2	L		Old Part Numbers	STAUFF Ordering Codes
19	30	180	Aluminium with chain	IA06-0-SI001	QRC-IA-06-DM-30/CN-W89-SI
.75	1.18	7.09		IA10-0-SI001	QRC-IA-10-DM-33/CN-W89-SI
30	33	200	Aluminium with chain	IA12-0-SI001	QRC-IA-12-DM-32/CN-W89-SI
1.18	1.30	7.87		IA19-0-SI001	QRC-IA-19-DM-47/CN-W89-SI
38	32	205	Aluminium with chain	IA25-0-SI001	QRC-IA-25-DM-41/CN-W89-SI
1.50	1.26	8.07		IA31-0-SI001	QRC-IA-31-DM-47/CN-W89-SI
45	47	275	Aluminium with chain	IA06-9-SI001	QRC-IA-06-DF-30/CN-W89-SI
1.77	1.85	10.83		IA10-9-SI001	QRC-IA-10-DF-33/CN-W89-SI
45	41	290	Aluminium with chain	IA12-9-SI001	QRC-IA-12-DF-32/CN-W89-SI
1.77	1.61	11.42		IA19-9-SI001	QRC-IA-19-DF-47/CN-W89-SI
70	47	275	Aluminium with chain	IA25-9-SI001	QRC-IA-25-DF-41/CN-W89-SI
2.76	1.85	10.83		IA31-9-SI001	QRC-IA-31-DF-47/CN-W89-SI

Dimensions (mm/in)			Material	Dust Plug for Female Body	
D1	D2	L		Old Part Numbers	STAUFF Ordering Codes
19	30	160	Aluminium with chain	IA06-9-SI001	QRC-IA-06-DF-30/CN-W89-SI
.75	1.18	6.30		IA10-9-SI001	QRC-IA-10-DF-33/CN-W89-SI
30	33	200	Aluminium with chain	IA12-9-SI001	QRC-IA-12-DF-32/CN-W89-SI
1.18	1.30	7.87		IA19-9-SI001	QRC-IA-19-DF-47/CN-W89-SI
38	32	205	Aluminium with chain	IA25-9-SI001	QRC-IA-25-DF-41/CN-W89-SI
1.50	1.26	8.07		IA31-9-SI001	QRC-IA-31-DF-47/CN-W89-SI
45	47	275	Aluminium with chain	IA06-9-SI001	QRC-IA-06-DF-30/CN-W89-SI
1.77	1.85	10.83		IA10-9-SI001	QRC-IA-10-DF-33/CN-W89-SI
43	41	240	Aluminium with chain	IA12-9-SI001	QRC-IA-12-DF-32/CN-W89-SI
1.69	1.61	9.45		IA19-9-SI001	QRC-IA-19-DF-47/CN-W89-SI
70	47	275	Aluminium with chain	IA25-9-SI001	QRC-IA-25-DF-41/CN-W89-SI
2.76	1.85	10.83		IA31-9-SI001	QRC-IA-31-DF-47/CN-W89-SI

In addition to the standard colours as stated above, plastic dust caps are also available in blue, green, yellow and black. Please use the old color codes BL, GN, GE and SW respectively instead of RT. Please use the STAUFF codes BU, GN, YE and BK respectively instead of RD.

IA



IA

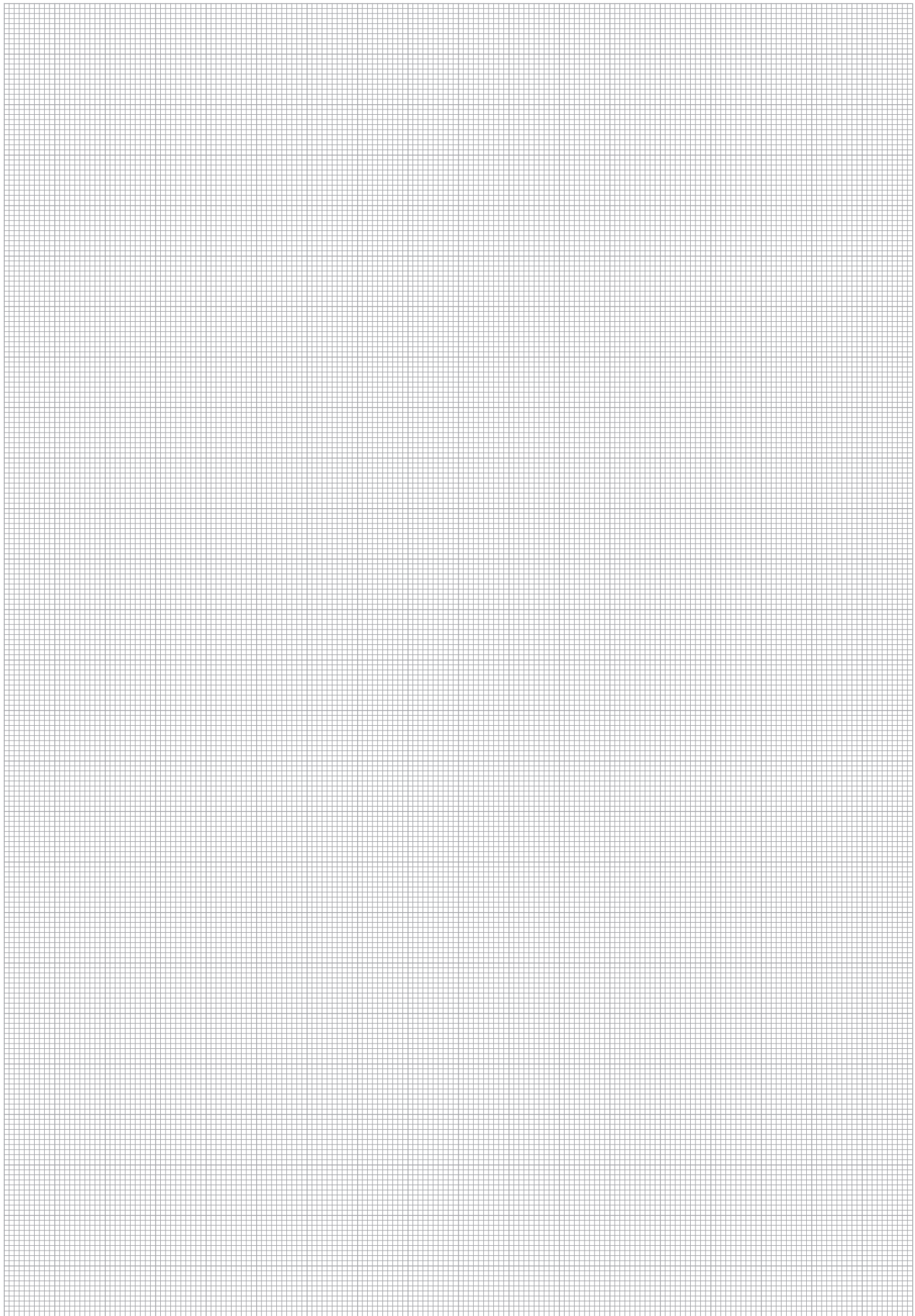

Series IB - Carbon Steel

Series IB - Overview	70	Series IB-38 - BG 12 - Nominal Size 38	72
Series IB-03 - BG 0 - Nominal Size 3,2	71	Series IB-51 - BG 14 - Nominal Size 51	72
Series IB-06 - BG 1 - Nominal Size 6,3	71	Series IB - Dust Protection	73
Series IB-10 - BG 2 - Nominal Size 10	71		
Series IB-12 - BG 3 - Nominal Size 12,5	71		
Series IB-19 - BG 6 - Nominal Size 19	72		
Series IB-25 - BG 8 - Nominal Size 25	72		



IB



Series IB • Carbon Steel

Material	Carbon Steel
Surface Finishing	Zinc-Nickel
Standard Seal Material(s)	NBR (Buna-N®) ²
Working Temperature	-25° C ... +100° C / -13° F ... +212° F
Valve Design	Poppet Valve
Connection	Push and actuate Push Sleeve
Disconnection	Actuate Push Sleeve
Connect Under Pressure	not allowed
Application	Industrial Hydraulic
ISO Interchange	ISO 7241-1, Series B



²Alternative seal materials are available on request.

Technical Data

Series	BG	DN Zoll Inch	DN metric ISO 4397	Q _{max}		Working Pressure		Bursting Pressure Connected		Female Body		Male Tip		Spillage	
				l/min	US GPM	bar	PSI	bar	PSI	bar	PSI	bar	PSI	ml	fl oz
IB-03	0	1/8"	3	9	2.38	500	7252	2700	39160	2300	29443	2400	34809	0,5	.0169
IB-06	1	1/4"	6,3	24	6.34	250	3626	1000	14504	1800	261067	1100	15954	1	.0338
IB-10	2	3/8"	10	46	12.15	250	3626	1300	18855	1400	20305	1400	20305	2,4	.0812
IB-12	3	1/2"	12,5	90	23.77	250	3626	1100	15954	1400	20305	1100	15954	3,9	.1319
IB-19	6	3/4"	19 (20)	220	58.12	250	3626	1200	17404	1300	18855	1000	14504	11,0	.3720
IB-25	8	1"	25	260	68.68	250	3626	1000	14504	1100	15954	1000	14504	19,0	.6425
IB-38	12	1 1/2"	38	757	199.98	200	2901	800	11603	800	11603	800	11603	95,0	3.2123
IB-51	14	2"	51	1000	264.17	100	1450	400	5801	400	5801	400	5801	170,0	5.7484

The indicated pressure ratings only apply to the coupling itself and depend on the connection type.

Flow Characteristics

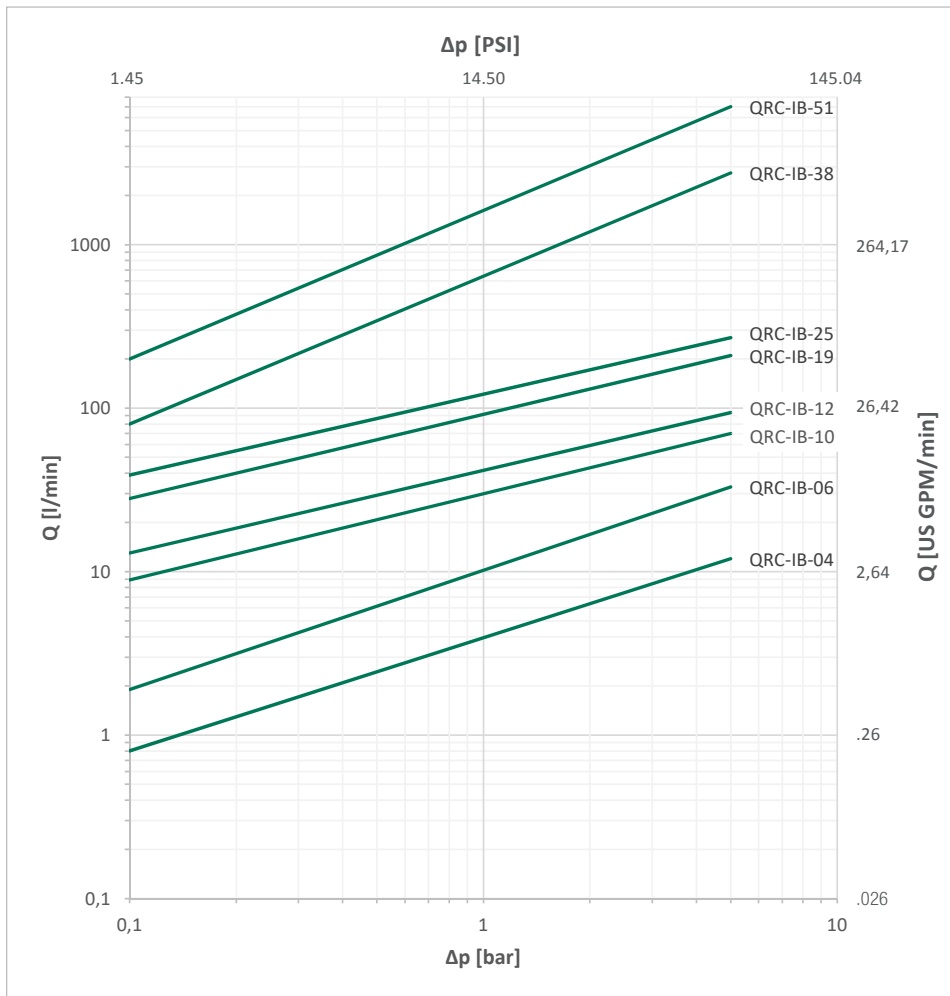

Please note: Unless otherwise stated, all flow characteristics have been determined with hydraulic oil with a kinematic viscosity of 28,8 - 35,2 mm²/s (28,8 - 35,2 cSt) and are only valid for components with non-reducing connections.



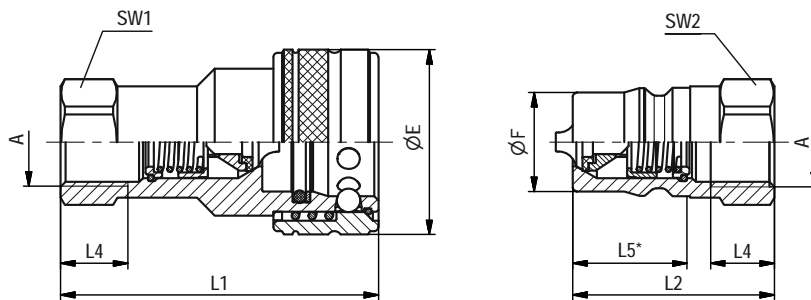

SW: Width across flats. All dimensions in mm (inch). Drawing similar Series IB-12.
* Insertion Male Tip.

Series IB-03 ▪ BG 0 ▪ Nominal Size 3,2

Port A	Dimensions (^{mm} / _{in})							Female Body		Weight (^{kg} / _{lbs}) ca. per 100	Male Tip		Weight (^{kg} / _{lbs}) ca. per 100
	ØE	ØF	L1	L2	L4 min	L5	SW1	SW2	Old Part Numbers		Old Part Numbers	Old Part Numbers	
Female Thread according to ANSI B 1.20.3													
 NPTF 1/8" -27	23	10,9	50,6	32		18,5	17	14	IB04-1-INF02	8,90	IB04-2-INF02	2	
	.90	.43	1.99	1.26		.73	.67	.55	QRC-IB-03-F-NF02-BT-W3	19.62	QRC-IB-03-M-NF02-B-W3	4.41	

Series IB-06 ▪ BG 1 ▪ Nominal Size 6,3

Port A	Dimensions (^{mm} / _{in})							Female Body		Weight (^{kg} / _{lbs}) ca. per 100	Male Tip		Weight (^{kg} / _{lbs}) ca. per 100
	ØE	ØF	L1	L2	L4 min	L5	SW1	SW2	Old Part Numbers		Old Part Numbers	Old Part Numbers	
Female Thread according to DIN 3852 - ANSI B.1.20.3													
 G 1/4"	28	14,2	60	38	12	21,5	19	19	IB06-1-IGF04	12,30	IB06-2-IGF04	3,90	
	1.1	.56	2.36	1.50	.47	.85	.75	.75	QRC-IB-06-F-G04-BT-W3	27.12	QRC-IB-06-M-G04-B-W3	8.60	
 NPTF 1/4" -18	28	14,2	60	38		21,5	19	19	IB06-1-INF04	12,40	IB06-2-INF04	4	
	1.1	.56	2.36	1.50		.85	.75	.75	QRC-IB-06-F-NF04-BT-W3	27.34	QRC-IB-06-M-NF04-B-W3	8.82	

Series IB-10 ▪ BG 2 ▪ Nominal Size 10

Port A	Dimensions (^{mm} / _{in})							Female Body		Weight (^{kg} / _{lbs}) ca. per 100	Male Tip		Weight (^{kg} / _{lbs}) ca. per 100
	ØE	ØF	L1	L2	L4 min	L5	SW1	SW2	Old Part Numbers		Old Part Numbers	Old Part Numbers	
Female Thread according to DIN 3852 - ANSI B.1.20.3													
 G 3/8"	35	19	60,5	42,5	12	24,2	22	22	IB10-1-IGF06	19,40	IB10-2-IGF06	6,10	
	1.38	.75	2.38	1.67	.47	.95	.87	.87	QRC-IB-10-F-G06-BT-W3	42.77	QRC-IB-10-M-G06-B-W3	13.45	
 NPTF 3/8" -18	35	19	60,5	42,5		24,2	22	22	IB10-1-INF06	19,60	IB10-2-INF06	6,20	
	1.38	.75	2.38	1.67		.95	.87	.87	QRC-IB-10-F-NF06-BT-W3	43.21	QRC-IB-10-M-NF06-B-W3	13.67	

Series IB-12 ▪ BG 3 ▪ Nominal Size 12,5

Port A	Dimensions (^{mm} / _{in})							Female Body		Weight (^{kg} / _{lbs}) ca. per 100	Male Tip		Weight (^{kg} / _{lbs}) ca. per 100
	ØE	ØF	L1	L2	L4 min	L5	SW1	SW2	Old Part Numbers		Old Part Numbers	Old Part Numbers	
Female Thread according to DIN 3852 - ANSI B.1.20.3													
 G 1/2"	44	23,55	75,7	48	14	27,2	27	27	IB12-1-IGF08	34,60	IB12-2-IGF08	11,20	
	1.73	.93	2.98	1.89	.55	.93	1.06	1.06	QRC-IB-12-F-G08-BT-W3	76.28	QRC-IB-12-M-G08-B-W3	24.69	
 NPTF 1/2" -14	44	23,55	75,7	48		27,2	27	27	IB12-1-INF08	34,90	IB12-2-INF08	11,50	
	1.73	.93	2.98	1.89		.93	1.06	1.06	QRC-IB-12-F-NF08-BT-W3	76.94	QRC-IB-12-M-NF08-B-W3	25.35	

Note: The connection of the two halves of a coupling is achieved depending on the type. It is important to observe the positive engagement of plug-type couplings and the secure tightening of screw-type couplings to the limit stop of the thread. Forced or improper separation will result in malfunction of the coupling.



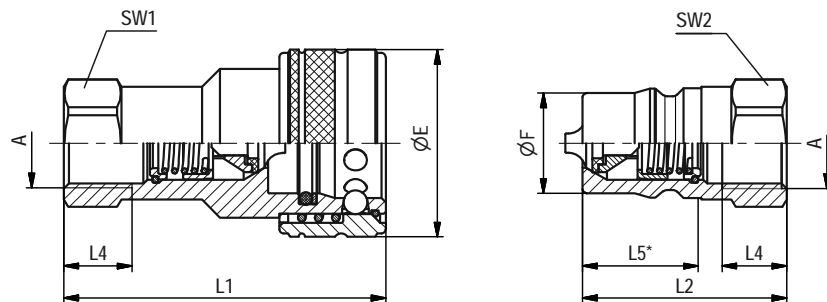

SW: Width across flats. All dimensions in mm (inch). Drawing similar Series IB-12.
* Insertion Male Tip.

Series IB-19 • BG 6 • Nominal Size 19

Port A	Dimensions (^{mm} / _{in})								Female Body		Weight (^{kg} / _{lbs}) ca. per 100	Male Tip		Weight (^{kg} / _{lbs}) ca. per 100
	ØE	ØF	L1	L2	L4 min	L5	SW1	SW2	Old Part Numbers	STAUFF Ordering Codes		Old Part Numbers	STAUFF Ordering Codes	
Female Thread according to DIN 3852 - ANSI B.1.20.3														
	G 3/4"	52	31,45	91,5	57	16	34	34	34	IB19-1-IGF12	54,80	IB19-2-IGF12	20,20	
		2.05	1.24	3.60	2.24	.63	1.34	1.34	1.34	QRC-IB-19-F-G12-BT-W3	120.81	QRC-IB-19-M-G12-B-W3	44.53	
	NPTF 3/4" -14	52	31,45	91,5	57		34	34	34	IB19-1-INF12	55,10	IB19-2-INF12	20,70	
		2.05	1.24	3.60	2.24		1.34	1.34	1.34	QRC-IB-19-F-NF12-BT-W3	121.47	QRC-IB-19-M-NF12-B-W3	45.64	

Series IB-25 • BG 8 • Nominal Size 25

Port A	Dimensions (^{mm} / _{in})								Female Body		Weight (^{kg} / _{lbs}) ca. per 100	Male Tip		Weight (^{kg} / _{lbs}) ca. per 100
	ØE	ØF	L1	L2	L4 min	L5	SW1	SW2	Old Part Numbers	STAUFF Ordering Codes		Old Part Numbers	STAUFF Ordering Codes	
Female Thread according to DIN 3852 - ANSI B.1.20.3														
	G 1"	60	37,77	105,8	65,5	18	39,3	41	41	IB25-1-IGF16	86	IB25-2-IGF16	35,50	
		2.36	1.49	4.17	2.58	.71	1.55	1.61	1.61	QRC-IB-25-F-G16-BT-W3	189.60	QRC-IB-25-M-G16-B-W3	78.26	
	NPTF 1" -11 1/2	60	37,77	105,8	65,5		39,3	41	41	IB25-1-INF16	87	IB25-2-INF16	36,40	
		2.36	1.49	4.17	2.58		1.55	1.61	1.61	QRC-IB-25-F-NF16-BT-W3	191.80	QRC-IB-25-M-NF16-B-W3	80.25	

Series IB-38 • BG 12 • Nominal Size 38

Port A	Dimensions (^{mm} / _{in})								Female Body		Weight (^{kg} / _{lbs}) ca. per 100	Male Tip		Weight (^{kg} / _{lbs}) ca. per 100
	ØE	ØF	L1	L2	L4 min	L5	SW1	SW2	Old Part Numbers	STAUFF Ordering Codes		Old Part Numbers	STAUFF Ordering Codes	
Female Thread according to DIN 3852 - ANSI B.1.20.3														
	G 1 1/4"	79	44,49	126,5	127	20	52	65	65	IB38-1-IGF20	200,80	IB38-2-IGF20	135,50	
		3.12	1.75	4.98	5.00	.79	2.05	2.56	2.56	QRC-IB-38-F-G20-BT-W3	442.69	QRC-IB-38-M-G20-B-W3	298.73	
	NPTF 1 1/4" -11 1/2	79	44,49	126,5	127		52	65	65	IB38-1-INF20	202	IB38-2-INF20	136,80	
		3.12	1.75	4.98	5.00		2.05	2.56	2.56	QRC-IB-38-F-NF20-BT-W3	445.33	QRC-IB-38-M-NF20-B-W3	301.59	

Series IB-51 • BG 14 • Nominal Size 51

Port A	Dimensions (^{mm} / _{in})								Female Body		Weight (^{kg} / _{lbs}) ca. per 100	Male Tip		Weight (^{kg} / _{lbs}) ca. per 100
	ØE	ØF	L1	L2	L4 min	L5	SW1	SW2	Old Part Numbers	STAUFF Ordering Codes		Old Part Numbers	STAUFF Ordering Codes	
Female Thread according to DIN 3852 - ANSI B.1.20.3														
	G 2"	105	63,2	142	142	24	63	90	90	IB51-1-IGF32	490	IB51-2-IGF32	310	
		4.13	2.49	5.59	5.59	.94	2.48	3.54	3.54	QRC-IB-51-F-G32-BT-W3	1080.27	QRC-IB-51-M-G32-B-W3	683.43	
	NPTF 2" -11 1/2	105	63,2	142	142		63	90	90	IB51-1-INF32	500	IB51-2-INF32	320	
		4.13	2.49	5.59	5.59		2.48	3.54	3.54	QRC-IB-51-F-NF32-BT-W3	1102.31	QRC-IB-51-M-NF32-B-W3	705.48	

Note: The connection of the two halves of a coupling is achieved depending on the type. It is important to observe the positive engagement of plug-type couplings and the secure tightening of screw-type couplings to the limit stop of the thread. Forced or improper separation will result in malfunction of the coupling.

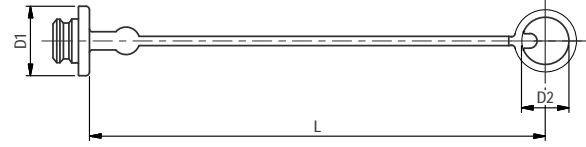
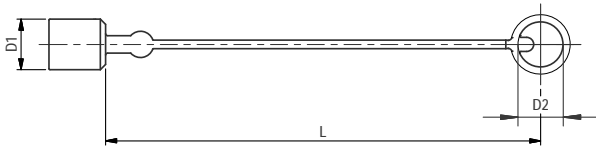

Series IB • Dust Protection

Dimensions (mm/in)			Material	Dust Cap for Male Tip	
D1	D2	L		Old Part Numbers	STAUFF Ordering Codes
18	23	240	Plastic (Colour: Red)	IB06-0-RT001	QRC-IB-06-DM-23-KI-RD
.71	.91	9.45			
23	24	240	Plastic (Colour: Red)	IB10-0-RT001	QRC-IB-10-DM-24-KI-RD
.91	.94	9.45			
29	28	245	Plastic (Colour: Red)	IB12-0-RT001	QRC-IB-12-DM-28-KI-RD
1.14	1.10	9.65			
36.0	38	245	Plastic (Colour: Red)	IB19-0-RT001	QRC-IB-19-DM-38-KI-RD
1.42	1.50	9.65			
44	44	253	Plastic (Colour: Red)	IB25-0-RT001	QRC-IB-25-DM-44-KI-RD
1.73	1.73	9.96			

Dimensions (mm/in)			Material	Dust Plug for Female Body	
D1	D2	L		Old Part Numbers	STAUFF Ordering Codes
26	23	240	Plastic (Colour: Red)	IB06-9-RT001	QRC-IB-06-DF-23-KI-RD
1.02	.91	9.45			
33	25	235	Plastic (Colour: Red)	IB10-9-RT001	QRC-IB-10-DF-25-KI-RD
1.30	.98	9.25			
38	29	240	Plastic (Colour: Red)	IB12-9-RT001	QRC-IB-12-DF-29-KI-RD
1.50	1.14	9.45			
49	38	240	Plastic (Colour: Red)	IB19-9-RT001	QRC-IB-19-DF-38-KI-RD
1.93	1.50	9.45			
60	46	245	Plastic (Colour: Red)	IB25-9-RT001	QRC-IB-25-DF-46-KI-RD
2.36	1.81	9.65			

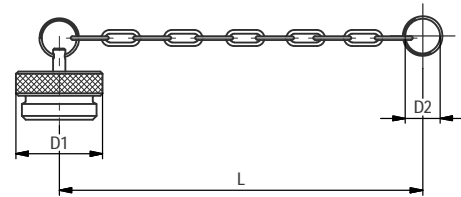
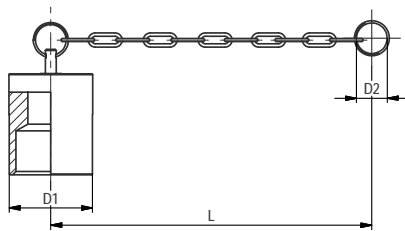

Dimensions (mm/in)			Material	Dust Cap for Male Tip	
D1	D2	L		Old Part Numbers	STAUFF Ordering Codes
22	28	245	Aluminium with chain	IB06-0-SI001	QRC-IB-06-DM-28/CN-W89-SI
.87	1.10	9.65			
27	30	155	Aluminium with chain	IB10-0-SI001	QRC-IB-10-DM-30/CN-W89-SI
1.06	1.18	6.10			
35	41	265	Aluminium with chain	IB12-0-SI001	QRC-IB-12-DM-41/CN-W89-SI
1.38	1.61	10.43			
42	30	250	Aluminium with chain	IB19-0-SI001	QRC-IB-19-DM-30/CN-W89-SI
1.65	1.18	9.84			
48	49	340	Aluminium with chain	IB25-0-SI001	QRC-IB-25-DM-49/CN-W89-SI
1.89	1.93	13.39			
55	46	225	Aluminium with chain	IB38-0-SI001	QRC-IB-38-DM-46/CN-W89-SI
2.17	1.81	8.86			
80	75	350	Aluminium with chain	IB51-0-SI001	QRC-IB-51-DM-75/CN-W89-SI
3.15	2.95	13.78			

Dimensions (mm/in)			Material	Dust Plug for Female Body	
D1	D2	L		Old Part Numbers	STAUFF Ordering Codes
22	30	210	Aluminium with chain	IB06-9-SI001	QRC-IB-06-DF-30/CN-W89-SI
.87	1.18	8.27			
22	30	155	Aluminium with chain	IB10-9-SI001	QRC-IB-10-DF-30/CN-W89-SI
.87	1.18	6.10			
28	41	305	Aluminium with chain	IB12-9-SI001	QRC-IB-12-DF-41/CN-W89-SI
1.10	1.61	12.01			
35	43	265	Aluminium with chain	IB19-9-SI001	QRC-IB-19-DF-43/CN-W89-SI
1.38	1.69	10.43			
44	41	240	Aluminium with chain	IB25-9-SI001	QRC-IB-25-DF-41/CN-W89-SI
1.73	1.61	9.45			
74	46	225	Aluminium with chain	IB38-9-SI001	QRC-IB-38-DF-46/CN-W89-SI
2.91	1.81	8.86			
105	75	350	Aluminium with chain	IB51-9-SI001	QRC-IB-51-DF-75/CN-W89-SI
4.13	2.95	13.78			

In addition to the standard colours as stated above, plastic dust caps are also available in blue, green, yellow and black. Please use the old color codes BL, GN, GE and SW respectively instead of RT. Please use the STAUFF codes BU, GN, YE and BK respectively instead of RD.

IB



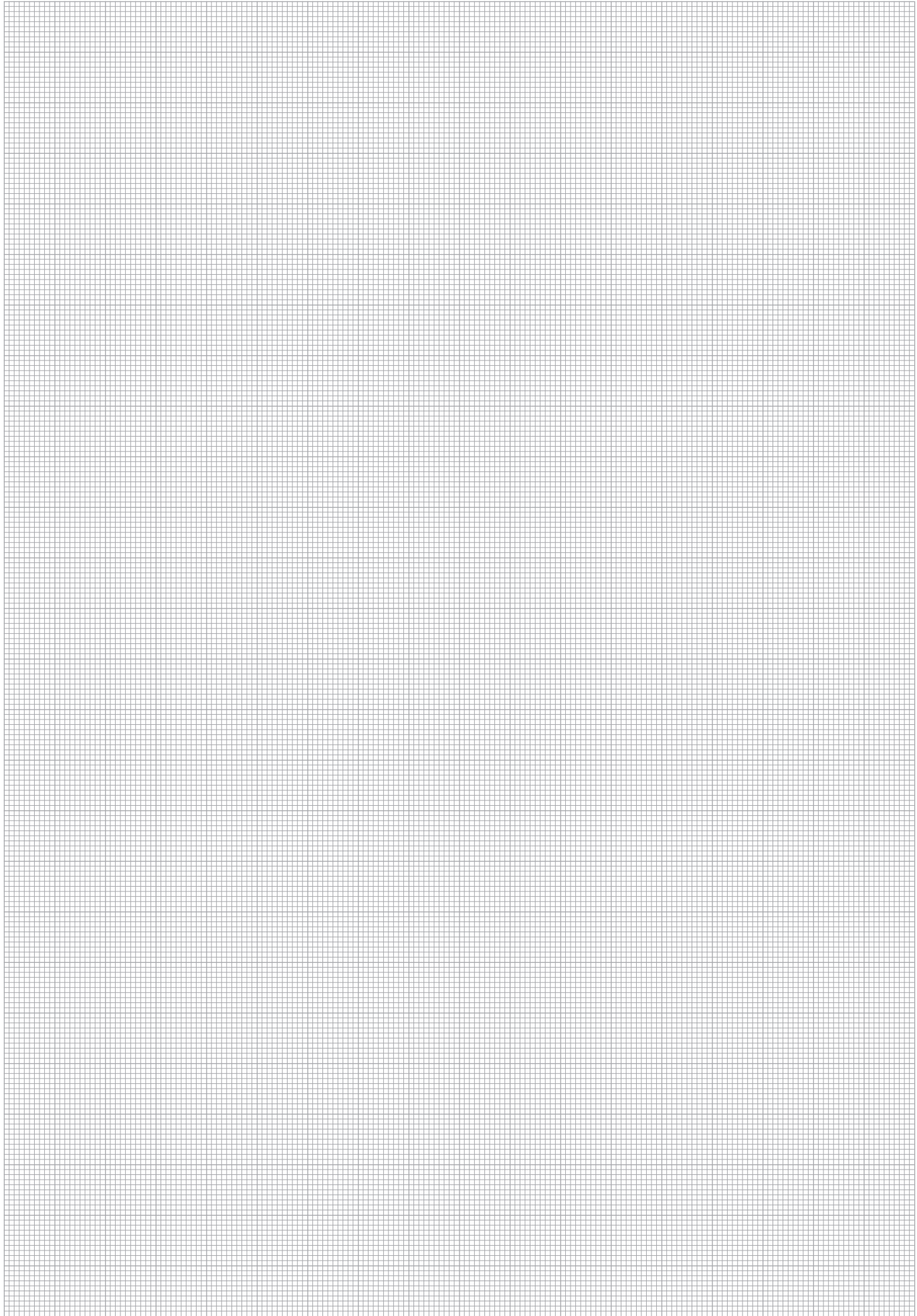

IB



Series IB • Brass

Series IB • Overview	76	Series IB-51 • BG 14 • Nominal Size 51	78
Series IB-06 • BG 1 • Nominal Size 6,3	77	Series IB • Dust Protection	79
Series IB-10 • BG 2 • Nominal Size 10	77		
Series IB-12 • BG 3 • Nominal Size 12,5	77		
Series IB-19 • BG 6 • Nominal Size 19	77		
Series IB-25 • BG 8 • Nominal Size 25	78		
Series IB-38 • BG 12 • Nominal Size 38	78		



IB



Series IB • Brass

Material	Brass
Surface Finishing	-
Standard Seal Material(s)	FKM (Viton®) ²
Working Temperature	-25° C ... +200° C / -13° F ... +392° F
Valve Design	Poppet Valve
Connection	Push and actuate Push Sleeve
Disconnection	Actuate Push Sleeve
Connect Under Pressure	not allowed
Application	Industrial Hydraulic
ISO Interchange	ISO 7241-1, Series B



²Alternative seal materials are available on request.

Technical Data

Series	BG	DN Zoll Inch	DN metric ISO 4397	Q _{max}		Working Pressure		Bursting Pressure Connected		Female Body		Male Tip		Spillage	
				l/min	US GPM	bar	PSI	bar	PSI	bar	PSI	bar	PSI	ml	fl oz
IB-06	1	1/4"	6,3	24	6.34	200	2901	1200	17404	800	11603	800	11603	1,0	.0338
IB-10	2	3/8"	10	46	12.15	200	2901	950	13779	850	12328	800	11603	2,4	.0812
IB-12	3	1/2"	12,5	90	23.77	180	2611	1000	14504	900	13053	720	10443	3,9	.1319
IB-19	6	3/4"	19 (20)	220	58.12	130	1885	800	11603	650	9427	550	7977	11,0	.3720
IB-25	8	1"	25	260	68.68	130	1885	600	8702	700	10153	550	7977	19,0	.6425
IB-38	12	1 1/2"	38	757	199.98	60	870	250	3626	250	3626	250	3626	95,0	3.2123
IB-51	14	2"	51	1000	264.17	50	725	200	2901	200	2908	200	2901	170	5.7484

The indicated pressure ratings only apply to the coupling itself and depend on the connection type.

Flow Characteristics

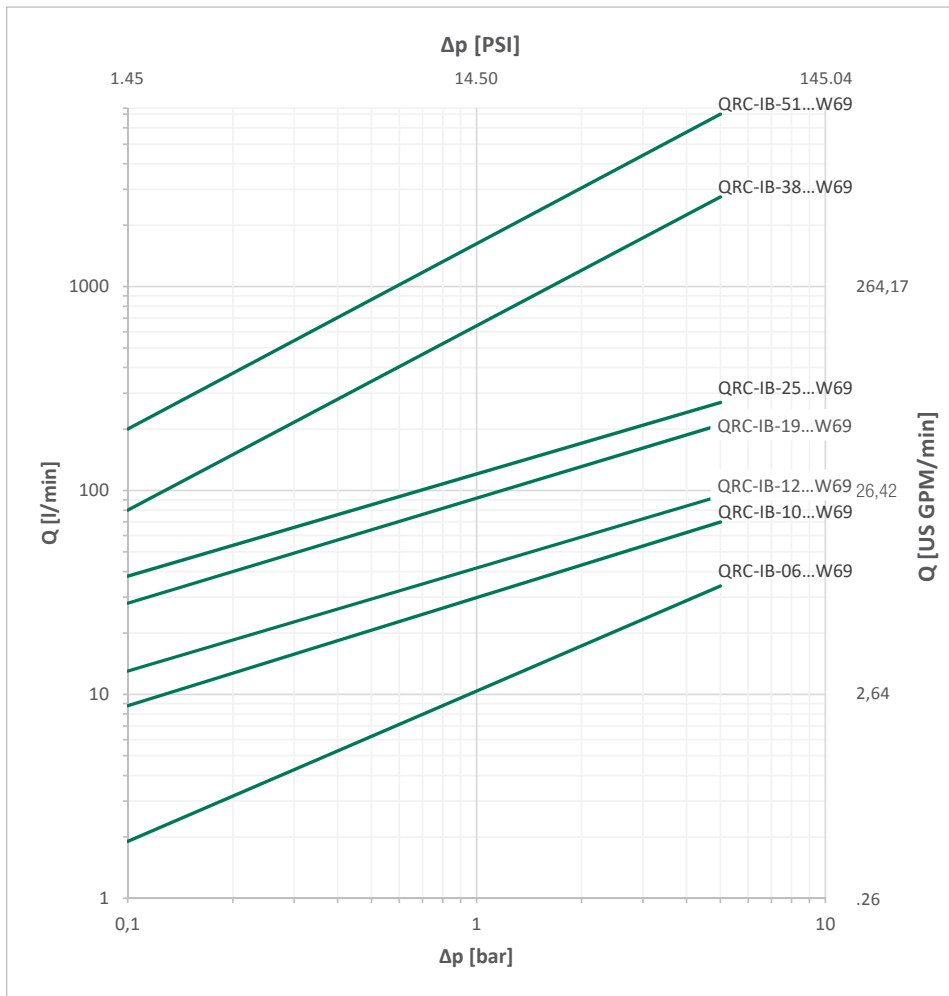

Please note: Unless otherwise stated, all flow characteristics have been determined with hydraulic oil with a kinematic viscosity of 28,8 - 35,2 mm²/s (28,8 - 35,2 cSt) and are only valid for components with non-reducing connections.



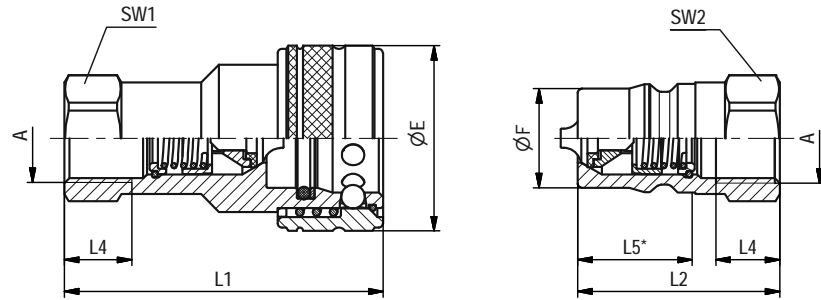

SW: Width across flats. All dimensions in mm (inch). Drawing similar Series IB-12.
* Insertion Male Tip.

Series IB-06 • BG 1 • Nominal Size 6,3

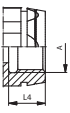
Port A	Dimensions (^{mm} / _{in})							Female Body		Weight (^{kg} / _{lbs}) ca. per 100	Male Tip		Weight (^{kg} / _{lbs}) ca. per 100
	ØE	ØF	L1	L2	L4	L5	SW1	SW2	Old Part Numbers		Old Part Numbers	STAUFF Ordering Codes	
Female Thread according to DIN 3852 - ANSI B 1.20.3													
 G 1/4"	28	14,2	60	38	12	21,5	19	19	IB06-1-IGF04-MS	13,30	IB06-2-IGF04-MS	4,30	
	1.1	.56	2.36	1.50	.47	.85	.75	.75	QRC-IB-06-F-G04-VT-W69	29.32	QRC-IB-06-M-G04-V-W69	9.48	
 NPTF 1/4" -18	28	14,2	60	38		21,5	19	19	IB06-1-INF04-MS	13,40	IB06-2-INF04-MS	4,40	
	1.1	.56	2.36	1.50		.85	.75	.75	QRC-IB-06-F-NF04-VT-W69	29.54	QRC-IB-06-M-NF04-V-W69	9.70	

Series IB-10 • BG 2 • Nominal Size 10

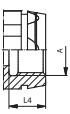
Port A	Dimensions (^{mm} / _{in})							Female Body		Weight (^{kg} / _{lbs}) ca. per 100	Male Tip		Weight (^{kg} / _{lbs}) ca. per 100
	ØE	ØF	L1	L2	L4	L5	SW1	SW2	Old Part Numbers		Old Part Numbers	STAUFF Ordering Codes	
Female Thread according to DIN 3852 - ANSI B 1.20.3													
 G 3/8"	35	19	67,2	42,5	12	28,2	22	22	IB10-1-IGF06-MS	21,30	IB10-2-IGF06-MS	6,90	
	1.38	.75	2.65	1.67	.47	1.11	.87	.87	QRC-IB-10-F-G06-VT-W69	46.96	QRC-IB-10-M-G06-V-W69	15.21	
 NPTF 3/8" -18	35	19	67,2	42,5		28,2	22	22	IB10-1-INF06-MS	21,50	IB10-2-INF06-MS	7,10	
	1.38	.75	2.65	1.67		1.11	.87	.87	QRC-IB-10-F-NF06-VT-W69	47.40	QRC-IB-10-M-NF06-V-W69	15.65	

Series IB-12 • BG 3 • Nominal Size 12,5

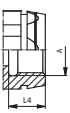
Port A	Dimensions (^{mm} / _{in})							Female Body		Weight (^{kg} / _{lbs}) ca. per 100	Male Tip		Weight (^{kg} / _{lbs}) ca. per 100
	ØE	ØF	L1	L2	L4	L5	SW1	SW2	Old Part Numbers		Old Part Numbers	STAUFF Ordering Codes	
Female Thread according to DIN 3852 - ANSI B 1.20.3													
 G 1/2"	44	23,55	75,7	48	14	27,2	27	27	IB12-1-IGF08-MS	39,60	IB12-2-IGF08-MS	12,40	
	1.73	.93	2.98	1.89	.55	1.07	1.06	1.06	QRC-IB-12-F-G08-VT-W69	87.30	QRC-IB-12-M-G08-V-W69	27.34	
 NPTF 1/2" -14	44	23,55	75,7	48		27,2	27	27	IB12-1-INF08-MS	40	IB12-2-INF08-MS	12,80	
	1.73	.93	2.98	1.89		1.07	1.06	1.06	QRC-IB-12-F-NF08-VT-W69	88.18	QRC-IB-12-M-NF08-V-W69	28.22	

Series IB-19 • BG 6 • Nominal Size 19

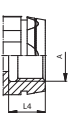
Port A	Dimensions (^{mm} / _{in})							Female Body		Weight (^{kg} / _{lbs}) ca. per 100	Male Tip		Weight (^{kg} / _{lbs}) ca. per 100
	ØE	ØF	L1	L2	L4	L5	SW1	SW2	Old Part Numbers		Old Part Numbers	STAUFF Ordering Codes	
Female Thread according to DIN 3852 - ANSI B 1.20.3													
 G 3/4"	52	31,45	91,5	57	14	34	34	34	IB19-1-IGF12-MS	59,70	IB19-2-IGF12-MS	22,60	
	2.05	1.24	3.60	2.24	.55	1.34	1.34	1.34	QRC-IB-19-F-G12-VT-W69	131.62	QRC-IB-19-M-G12-V-W69	49.82	
 NPTF 3/4" -14	52	31,45	91,5	57		34	34	34	IB19-1-INF12-MS	60,10	IB19-2-INF12-MS	23	
	2.05	1.24	3.60	2.24		1.34	1.34	1.34	QRC-IB-19-F-NF12-VT-W69	132.50	QRC-IB-19-M-NF12-V-W69	50.71	

Note: The connection of the two halves of a coupling is achieved depending on the type. It is important to observe the positive engagement of plug-type couplings and the secure tightening of screw-type couplings to the limit stop of the thread. Forced or improper separation will result in malfunction of the coupling.



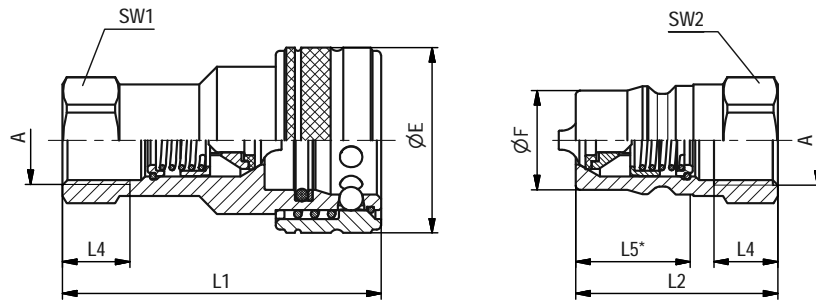

SW: Width across flats. All dimensions in mm (inch). Drawing similar Series IB-12.
* Insertion Male Tip.

Series IB-25 ▪ BG 8 ▪ Nominal Size 25

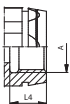
Port A	Dimensions (mm/in)							Female Body		Weight (^{kg} /lbs) ca. per 100	Male Tip		Weight (^{kg} /lbs) ca. per 100
	ØE	ØF	L1	L2	L4 min	L5	SW1	SW2	Old Part Numbers		Old Part Numbers	STAUFF Ordering Codes	
Female Thread according to DIN 3852 - ANSI B 1.20.3													
 G 1"	60	37,8	105,8	65,5	16	39,3	41	41	IB25-1-IGF16-MS	93,80	IB25-2-IGF16-MS	39,20	
	2.36	1.49	4.17	2.58	.63	1.55	1.61	1.61	QRC-IB-25-F-G16-VT-W69	206.79	QRC-IB-25-M-G16-V-W69	86.42	
NPTF 1" -11 1/2	60	37,8	105,8	65,5		39,3	41	41	IB25-1-INF16-MS	95	IB25-2-INF16-MS	40,30	
	2.36	1.49	4.17	2.58		1.55	1.61	1.61	QRC-IB-25-F-NF16-VT-W69	209.44	QRC-IB-25-M-NF16-V-W69	88.85	

Series IB-38 ▪ BG 12 ▪ Nominal Size 38

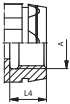
Port A	Dimensions (mm/in)							Female Body		Weight (^{kg} /lbs) ca. per 100	Male Tip		Weight (^{kg} /lbs) ca. per 100
	ØE	ØF	L1	L2	L4 min	L5	SW1	SW2	Old Part Numbers		Old Part Numbers	STAUFF Ordering Codes	
Female Thread according to DIN 3852 - ANSI B 1.20.3													
 G 1 1/4"	78,5	44,5	126,5	127	20	52	65	65	IB38-1-IGF20-MS	219,80	IB38-2-IGF20-MS	145,20	
	3.09	1.75	4.98	5.00	.79	2.05	2.56	2.56	QRC-IB-38-F-G20-VT-W69	484.58	QRC-IB-38-M-G20-V-W69	320.11	
NPTF 1 1/4" -11 1/2	78,5	44,5	126,5	127		52	65	65	IB38-1-INF20-MS	217	IB38-2-INF20-MS	146,90	
	3.09	1.75	4.98	5.00		2.05	2.56	2.56	QRC-IB-38-F-NF20-VT-W69	478.40	QRC-IB-38-M-NF20-V-W69	323.87	
G 1 1/2"	78,5	44,5	126,5	127	22	52	65	65	IB38-1-IGF24-MS	212,60	IB38-2-IGF24-MS	137,10	
	3.09	1.75	4.98	5.00	.87	2.05	2.56	2.56	QRC-IB-38-F-G24-VT-W69	468.70	QRC-IB-38-M-G24-V-W69	302.25	
NPTF 1 1/2" -11 1/2	78,5	44,5	126,5	127		52	65	65	IB38-1-INF24-MS	214,80	IB38-2-INF24-MS	139	
	3.09	1.75	4.98	5.00		2.05	2.56	2.56	QRC-IB-38-F-NF24-VT-W69	473.55	QRC-IB-38-M-NF24-V-W69	306.44	

Series IB-51 ▪ BG 14 ▪ Nominal Size 51

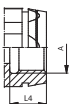
Port A	Dimensions (mm/in)							Female Body		Weight (^{kg} /lbs) ca. per 100	Male Tip		Weight (^{kg} /lbs) ca. per 100
	ØE	ØF	L1	L2	L4 min	L5	SW1	SW2	Old Part Numbers		Old Part Numbers	STAUFF Ordering Codes	
Female Thread according to DIN 3852 - ANSI B 1.20.3													
 G 2"	105	63,2	142	142,5	24	63,5	90	90	IB51-1-IGF32-MS	532	IB51-2-IGF32-MS	347	
	4.13	2.49	5.59	5.61	.94	2.5	3.54	3.54	QRC-IB-51-F-G32-VT-W69	1172.86	QRC-IB-51-M-G32-V-W69	765	
NPTF 2" -11 1/2	105	63,2	142	142,5		63,5	90	90	IB51-1-INF32-MS	537	IB51-2-INF32-MS	352	
	4.13	2.49	5.59	5.61		2.5	3.54	3.54	QRC-IB-51-F-NF32-VT-W69	1183.88	QRC-IB-51-M-NF32-V-W69	776.03	

Note: The connection of the two halves of a coupling is achieved depending on the type. It is important to observe the positive engagement of plug-type couplings and the secure tightening of screw-type couplings to the limit stop of the thread. Forced or improper separation will result in malfunction of the coupling.

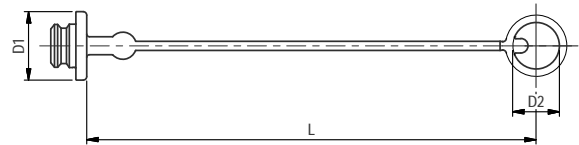
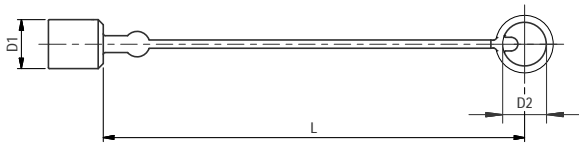

Series IB • Dust Protection

Dimensions (mm/in)			Material	Dust Cap for Male Tip	
D1	D2	L		Old Part Numbers	STAUFF Ordering Codes
18	23	240	Plastic (Colour: Red)	IB06-0-RT001	QRC-IB-06-DM-23-KI-RD
.71	.91	9.45			
23	24	240	Plastic (Colour: Red)	IB10-0-RT001	QRC-IB-10-DM-24-KI-RD
.91	.94	9.45			
29	28	245	Plastic (Colour: Red)	IB12-0-RT001	QRC-IB-12-DM-28-KI-RD
1.14	1.10	9.65			
36,0	38	245	Plastic (Colour: Red)	IB19-0-RT001	QRC-IB-19-DM-38-KI-RD
1.42	1.50	9.65			
44	44	253	Plastic (Colour: Red)	IB25-0-RT001	QRC-IB-25-DM-44-KI-RD
1.73	1.73	9.96			

Dimensions (mm/in)			Material	Dust Plug for Female Body	
D1	D2	L		Old Part Numbers	STAUFF Ordering Codes
26	23	240	Plastic (Colour: Red)	IB06-9-RT001	QRC-IB-06-DF-23-KI-RD
1.02	.91	9.45			
33	25	235	Plastic (Colour: Red)	IB10-9-RT001	QRC-IB-10-DF-25-KI-RD
1.30	.98	9.25			
38	29	240	Plastic (Colour: Red)	IB12-9-RT001	QRC-IB-12-DF-29-KI-RD
1.50	1.14	9.45			
49	38	240	Plastic (Colour: Red)	IB19-9-RT001	QRC-IB-19-DF-38-KI-RD
1.93	1.50	9.45			
60	46	245	Plastic (Colour: Red)	IB25-9-RT001	QRC-IB-25-DF-46-KI-RD
2.36	1.81	9.65			

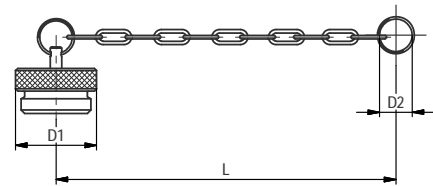
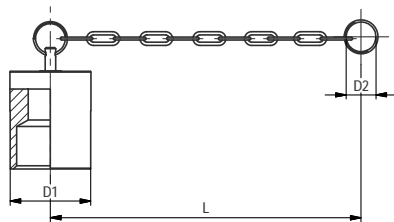

Dimensions (mm/in)			Material	Dust Cap for Male Tip	
D1	D2	L		Old Part Numbers	STAUFF Ordering Codes
22	28	245	Aluminium with chain	IB06-0-SI001	QRC-IB-06-DM-28/CN-W89-SI
.87	1.10	9.65			
27	30	155	Aluminium with chain	IB10-0-SI001	QRC-IB-10-DM-30/CN-W89-SI
1.06	1.18	6.10			
35	41	265	Aluminium with chain	IB12-0-SI001	QRC-IB-12-DM-41/CN-W89-SI
1.38	1.61	10.43			
42	30	250	Aluminium with chain	IB19-0-SI001	QRC-IB-19-DM-30/CN-W89-SI
1.65	1.18	9.84			
48	49	340	Aluminium with chain	IB25-0-SI001	QRC-IB-25-DM-49/CN-W89-SI
1.89	1.93	13.39			
55	46	225	Aluminium with chain	IB38-0-SI001	QRC-IB-38-DM-46/CN-W89-SI
2.17	1.81	8.86			
80	75	350	Aluminium with chain	IB51-0-SI001	QRC-IB-51-DM-75/CN-W89-SI
3.15	2.95	13.78			

Dimensions (mm/in)			Material	Dust Plug for Female Body	
D1	D2	L		Old Part Numbers	STAUFF Ordering Codes
22	30	210	Aluminium with chain	IB06-9-SI001	QRC-IB-06-DF-30/CN-W89-SI
.87	1.18	8.27			
27	30	155	Aluminium with chain	IB10-9-SI001	QRC-IB-10-DF-30/CN-W89-SI
1.06	1.18	6.10			
28	41	305	Aluminium with chain	IB12-9-SI001	QRC-IB-12-DF-41/CN-W89-SI
1.10	1.61	12.01			
35	43	265	Aluminium with chain	IB19-9-SI001	QRC-IB-19-DF-43/CN-W89-SI
1.38	1.69	10.43			
44	41	240	Aluminium with chain	IB25-9-SI001	QRC-IB-25-DF-41/CN-W89-SI
1.73	1.61	9.45			
74	46	225	Aluminium with chain	IB38-9-SI001	QRC-IB-38-DF-46/CN-W89-SI
2.91	1.81	8.86			
105	75	350	Aluminium with chain	IB51-9-SI001	QRC-IB-51-DF-75/CN-W89-SI
4.13	2.95	13.78			

In addition to the standard colours as stated above, plastic dust caps are also available in blue, green, yellow and black. Please use the old color codes BL, GN, GE and SW respectively instead of RT. Please use the STAUFF codes BU, GN, YE and BK respectively instead of RD.

IB

IB

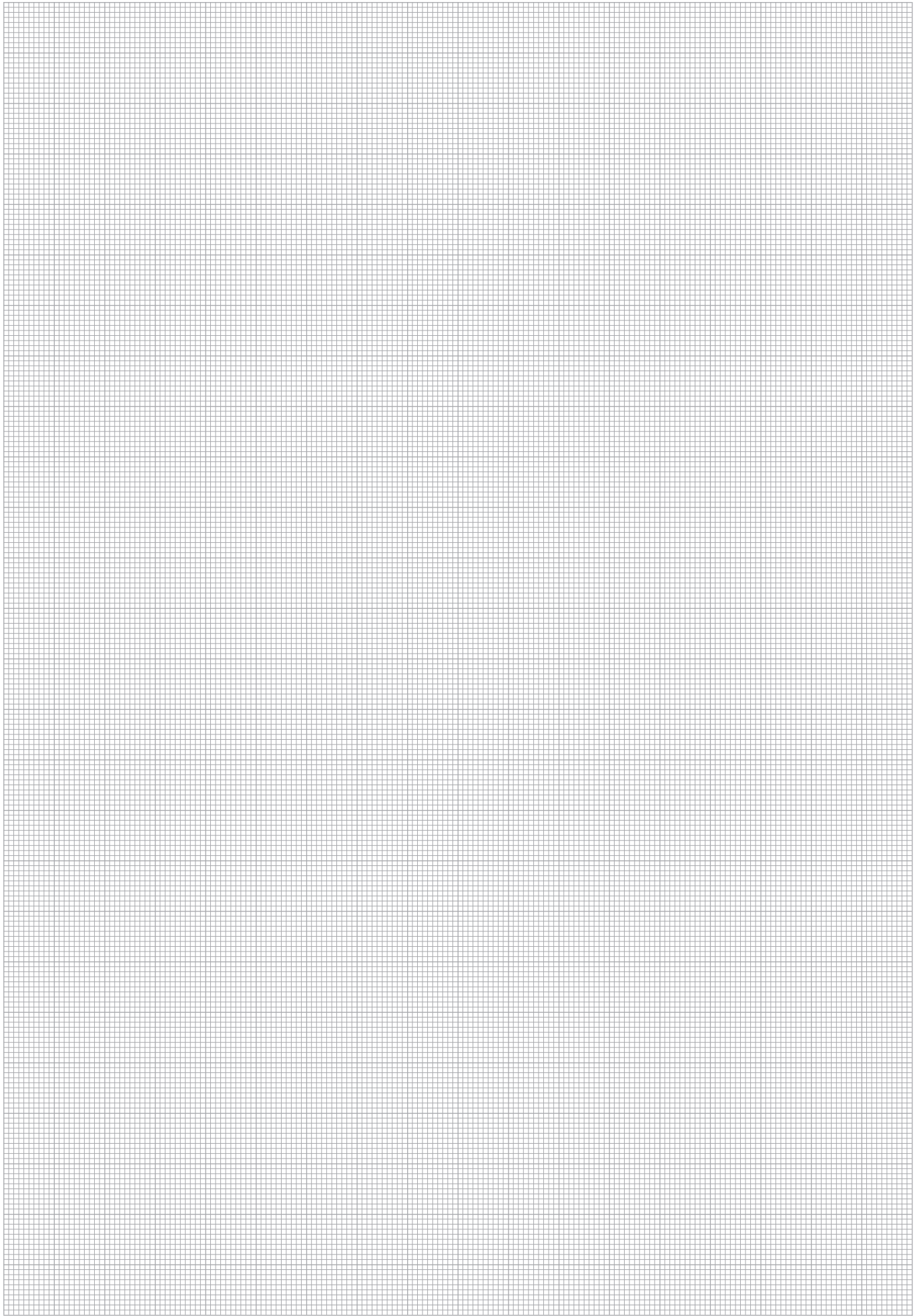

Series IB - Stainless Steel

Series IB - Overview	82	Series IB-51 - BG 14 - Nominal Size 51	84
Series IB-06 - BG 1 - Nominal Size 6,3	83	Series IB - Dust Protection	85
Series IB-10 - BG 2 - Nominal Size 10	83		
Series IB-12 - BG 3 - Nominal Size 12,5	83		
Series IB-19 - BG 6 - Nominal Size 19	83		
Series IB-25 - BG 8 - Nominal Size 25	84		
Series IB-38 - BG 12 - Nominal Size 38	84		



IB



Series IB - Stainless Steel

Material	Stainless Steel V4A (AISI 316)
Surface Finishing	-
Standard Seal Material(s)	FKM (Viton®) ²
Working Temperature	-25° C ... +200° C / -13° F ... +392° F
Valve Design	Poppet Valve
Connection	Push and actuate Push Sleeve
Disconnection	Actuate Push Sleeve
Connect Under Pressure	not allowed
Application	Industrial Hydraulic
ISO Interchange	ISO 7241-1, Series B



²Alternative seal materials are available on request.

Technical Data

Series	BG	DN Zoll Inch	DN metric ISO 4397	Q _{max}		Working Pressure		Bursting Pressure Connected		Female Body		Male Tip		Spillage	
				l/min	US GPM	bar	PSI	bar	PSI	bar	PSI	bar	PSI	ml	fl oz
IB-06	1	1/4"	6,3	24	6.34	350	5076	1600	23206	1500	21756	1700	24656	1,0	.0338
IB-10	2	3/8"	10	46	12.15	300	4351	2100	30458	1100	15954	1100	15954	2,4	.0812
IB-12	3	1/2"	12,5	90	23.77	300	4351	1500	21756	1400	20305	1500	21756	3,9	.1319
IB-19	6	3/4"	19 (20)	220	58.12	220	3191	1000	14504	900	13053	1000	14504	11,0	.3720
IB-25	8	1"	25	260	68.68	200	2901	850	12328	650	9427	600	8702	19,0	.6425
IB-38	12	1 1/2"	38	757	199.98	80	1160	250	3626	250	3626	250	3626	95,0	3.2123
IB-51	14	2"	51	1000	264.17	60	870	200	2901	200	2901	200	2901	170	5.7484

The indicated pressure ratings only apply to the coupling itself and depend on the connection type.

Flow Characteristics

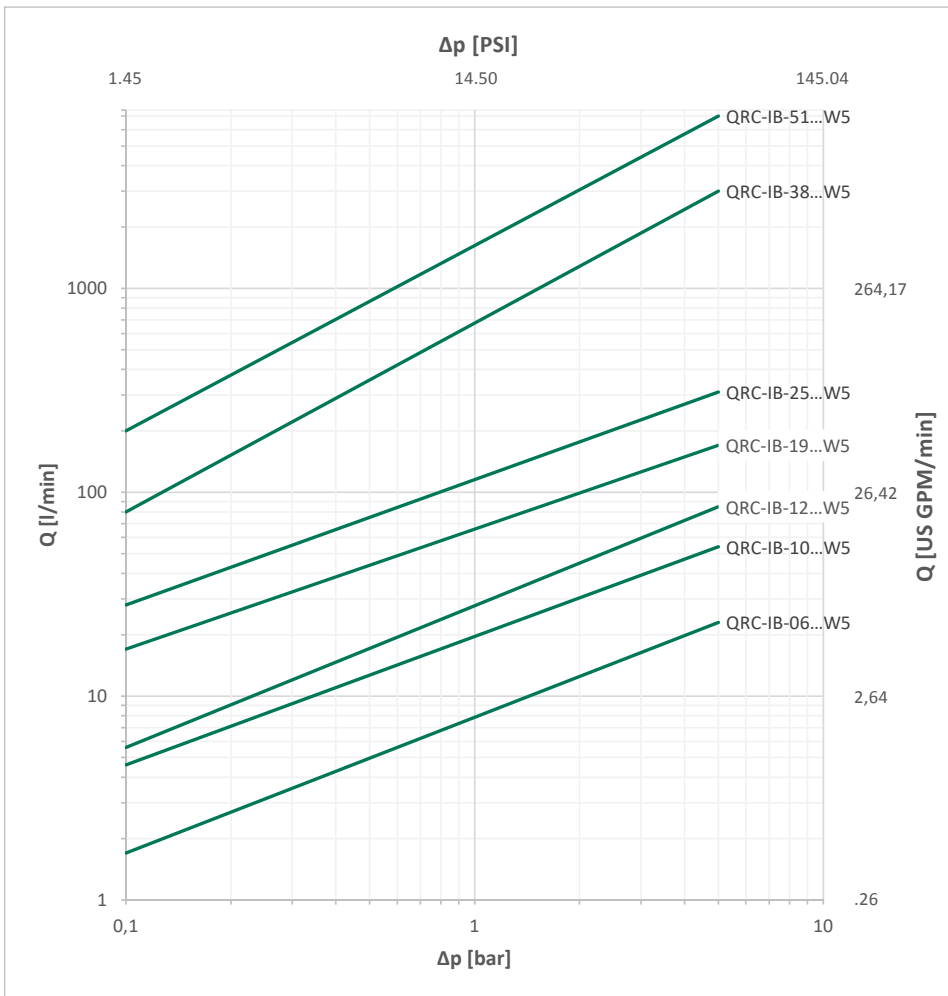

Please note: Unless otherwise stated, all flow characteristics have been determined with hydraulic oil with a kinematic viscosity of 28,8 - 35,2 mm²/s (28,8 - 35,2 cSt) and are only valid for components with non-reducing connections.



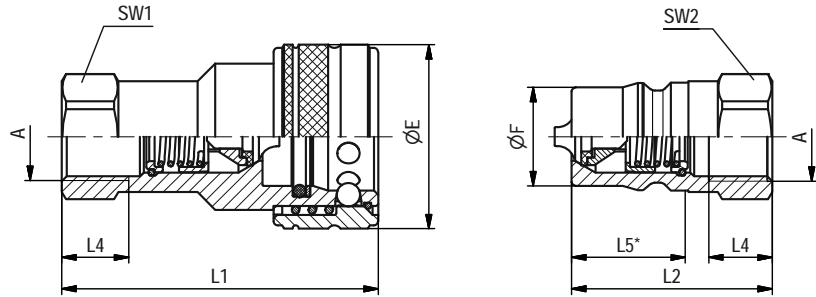

SW: Width across flats. All dimensions in mm (inch). Drawing similar Series IB-12.
* Insertion Male Tip.

Series IB-06 • BG 1 • Nominal Size 6,3

Port A	Dimensions (^{mm} / _{in})							Female Body		Weight (^{kg} / _{lbs}) ca. per 100	Male Tip		Weight (^{kg} / _{lbs}) ca. per 100
	ØE	ØF	L1	L2	L4 min	L5	SW1	SW2	Old Part Numbers		Old Part Numbers	STAUFF Ordering Codes	
Female Thread according to DIN 3852 - ANSI B 1.20.3													
	G 1/4"	28	14,2	60	38	12	21,5	19	19	IB06-1-IGF04-VA	13	IB06-2-IGF04-VA	4
		1.10	.56	2.36	1.50	.47	.85	.75	.75	QRC-IB-06-F-G04-VT-W5	28.66	QRC-IB-06-M-G04-V-W5	8.82
	NPTF 1/4" -18	28	14,2	60	38		21,5	19	19	IB06-1-INF04-VA	13,10	IB06-2-INF04-VA	4,10
		1.10	.56	2.36	1.50		.85	.75	.75	QRC-IB-06-F-NF04-VT-W5	28.88	QRC-IB-06-M-NF04-V-W5	9.04

Series IB-10 • BG 2 • Nominal Size 10

Port A	Dimensions (^{mm} / _{in})							Female Body		Weight (^{kg} / _{lbs}) ca. per 100	Male Tip		Weight (^{kg} / _{lbs}) ca. per 100
	ØE	ØF	L1	L2	L4 min	L5	SW1	SW2	Old Part Numbers		Old Part Numbers	STAUFF Ordering Codes	
Female Thread according to DIN 3852 - ANSI B 1.20.3													
	G 3/8"	35	19,1	65,2	40,5	12	24,2	22	22	IB10-1-IGF06-VA	19,70	IB10-2-IGF06-VA	6
		1.38	.75	2.57	1.59	.47	.95	.87	.87	QRC-IB-10-F-G06-VT-W5	43.43	QRC-IB-10-M-G06-V-W5	13.23
	NPTF 3/8" -18	35	19,1	65,2	40,5		24,2	22	22	IB10-1-INF06-VA	19,80	IB10-2-INF06-VA	6,10
		1.38	.75	2.57	1.59		.95	.87	.87	QRC-IB-10-F-NF06-VT-W5	43.65	QRC-IB-10-M-NF06-V-W5	13.45

Series IB-12 • BG 3 • Nominal Size 12,5

Port A	Dimensions (^{mm} / _{in})							Female Body		Weight (^{kg} / _{lbs}) ca. per 100	Male Tip		Weight (^{kg} / _{lbs}) ca. per 100
	ØE	ØF	L1	L2	L4 min	L5	SW1	SW2	Old Part Numbers		Old Part Numbers	STAUFF Ordering Codes	
Female Thread according to DIN 3852 - ANSI B 1.20.3													
	G 1/2"	44	23,55	73,7	46	14	27,2	27	27	IB12-1-IGF08-VA	34,60	IB12-2-IGF08-VA	10,70
		1.73	.93	2.90	1.81	.55	1.07	1.06	1.06	QRC-IB-12-F-G08-VT-W5	76.28	QRC-IB-12-M-G08-V-W5	23.59
	NPTF 1/2" -14	44	23,55	73,7	46		27,2	27	27	IB12-1-INF08-VA	35	IB12-2-INF08-VA	10,90
		1.73	.93	2.90	1.81		1.07	1.06	1.06	QRC-IB-12-F-NF08-VT-W5	77.16	QRC-IB-12-M-NF08-V-W5	24.03

Series IB-19 • BG 6 • Nominal Size 19

Port A	Dimensions (^{mm} / _{in})							Female Body		Weight (^{kg} / _{lbs}) ca. per 100	Male Tip		Weight (^{kg} / _{lbs}) ca. per 100
	ØE	ØF	L1	L2	L4 min	L5	SW1	SW2	Old Part Numbers		Old Part Numbers	STAUFF Ordering Codes	
Female Thread according to DIN 3852 - ANSI B 1.20.3													
	G 3/4"	51,8	31,45	91,5	57	16	34	34	34	IB19-1-IGF12-VA	56	IB19-2-IGF12-VA	21
		2.03	1.24	3.60	2.24	.63	1.34	1.34	1.34	QRC-IB-19-F-G12-VT-W5	123.46	QRC-IB-19-M-G12-V-W5	46.30
	NPTF 3/4" -14	51,8	31,45	91,5	57		34	34	34	IB19-1-INF12-VA	56,50	IB19-2-INF12-VA	21,50
		2.03	1.24	3.60	2.24		1.34	1.34	1.34	QRC-IB-19-F-NF12-VT-W5	124.56	QRC-IB-19-M-NF12-V-W5	47.40

Note: The connection of the two halves of a coupling is achieved depending on the type. It is important to observe the positive engagement of plug-type couplings and the secure tightening of screw-type couplings to the limit stop of the thread. Forced or improper separation will result in malfunction of the coupling.



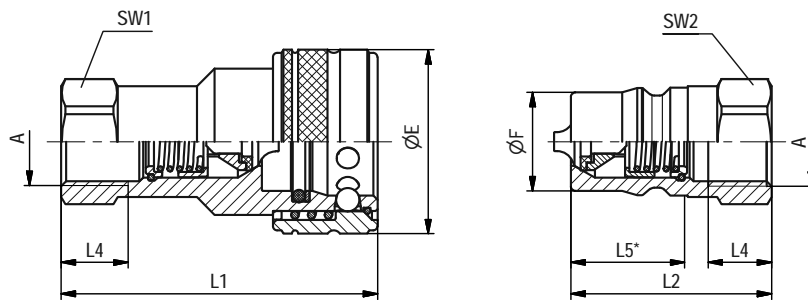

SW: Width across flats. All dimensions in mm (inch). Drawing similar Series IB-12.
* Insertion Male Tip.

Series IB-25 ▪ BG 8 ▪ Nominal Size 25

Port A	Dimensions (^{mm} / _{in})								Female Body		Weight (^{kg} / _{lbs}) ca. per 100	Male Tip		Weight (^{kg} / _{lbs}) ca. per 100
	ØE	ØF	L1	L2	L4 min	L5	SW1	SW2	Old Part Numbers	STAUFF Ordering Codes		Old Part Numbers	STAUFF Ordering Codes	
Female Thread according to DIN 3852 - ANSI B 1.20.3														
G 1"	60	37,8	103,8	63,5	18	39,3	41	41	IB25-1-IGF16-VA	90,80	IB25-2-IGF16-VA	34,20		
	2.36	1.49	4.09	2.50	.71	1.55	1.61	1.61	QRC-IB-25-F-G16-VT-W5	200.18	QRC-IB-25-M-G16-V-W5	75.40		
NPTF 1" -11 1/2	60	37,8	103,8	63,5		39,3	41	41	IB25-1-INF16-VA	91,80	IB25-2-INF16-VA	35,20		
	2.36	1.49	4.09	2.50		1.55	1.61	1.61	QRC-IB-25-F-NF16-VT-W5	202.38	QRC-IB-25-M-NF16-V-W5	77.60		

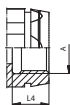

Series IB-38 ▪ BG 12 ▪ Nominal Size 38

Port A	Dimensions (^{mm} / _{in})								Female Body		Weight (^{kg} / _{lbs}) ca. per 100	Male Tip		Weight (^{kg} / _{lbs}) ca. per 100
	ØE	ØF	L1	L2	L4 min	L5	SW1	SW2	Old Part Numbers	STAUFF Ordering Codes		Old Part Numbers	STAUFF Ordering Codes	
Female Thread according to DIN 3852 - ANSI B 1.20.3														
G 1 1/4"	78,5	44,45	126,5	127	20	52	65	65	IB38-1-IGF20-VA	216,60	IB38-2-IGF20-VA	138,20		
	3.09	1.75	4.98	5.00	.79	2.05	2.56	2.56	QRC-IB-38-F-G20-VT-W5	477.52	QRC-IB-38-M-G20-V-W5	304.68		
NPTF 1 1/4" -11 1/2	78,5	44,45	126,5	127		52	65	65	IB38-1-INF20-VA	217,80	IB38-2-INF20-VA	139,40		
	3.09	1.75	4.98	5.00		2.05	2.56	2.56	QRC-IB-38-F-NF20-VT-W5	480.17	QRC-IB-38-M-NF20-V-W5	307.32		
G 1 1/2"	78,5	44,45	126,5	127	22	52	65	65	IB38-1-IGF24-VA	208	IB38-2-IGF24-VA	130,40		
	3.09	1.75	4.98	5.00	.87	2.05	2.56	2.56	QRC-IB-38-F-G24-VT-W5	458.56	QRC-IB-38-M-G24-V-W5	287.48		
NPTF 1 1/2" -11 1/2	78,5	44,45	126,5	127		52	65	65	IB38-1-INF24-VA	209,50	IB38-2-INF24-VA	132		
	3.09	1.75	4.98	5.00		2.05	2.56	2.56	QRC-IB-38-F-NF24-VT-W5	461.87	QRC-IB-38-M-NF24-V-W5	291.01		

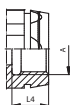

Series IB-51 ▪ BG 14 ▪ Nominal Size 51

Port A	Dimensions (^{mm} / _{in})								Female Body		Weight (^{kg} / _{lbs}) ca. per 100	Male Tip		Weight (^{kg} / _{lbs}) ca. per 100
	ØE	ØF	L1	L2	L4 min	L5	SW1	SW2	Old Part Numbers	STAUFF Ordering Codes		Old Part Numbers	STAUFF Ordering Codes	
Female Thread according to DIN 3852 - ANSI B 1.20.3														
G 2"	105	63,2	142	142,5	24	63,5	90	90	IB51-1-IGF32-VA	497	IB51-2-IGF32-VA	329		
	4.13	2.49	5.59	5.61	.94	2.50	3.54	3.54	QRC-IB-51-F-G32-VT-W5	1095.70	QRC-IB-51-M-G32-V-W5	725.32		
NPTF 2" -11 1/2	105	63,2	142	142,5		63,5	90	90	IB51-1-INF32-VA	505	IB51-2-INF32-VA	330		
	4.13	2.49	5.59	5.61		2.50	3.54	3.54	QRC-IB-51-F-NF32-VT-W5	1113.33	QRC-IB-51-M-NF32-V-W5	727.53		

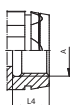

Note: The connection of the two halves of a coupling is achieved depending on the type. It is important to observe the positive engagement of plug-type couplings and the secure tightening of screw-type couplings to the limit stop of the thread. Forced or improper separation will result in malfunction of the coupling.

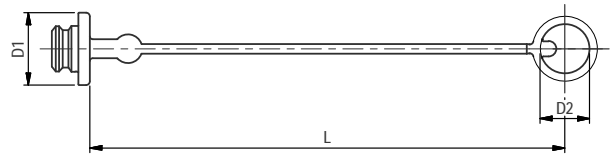
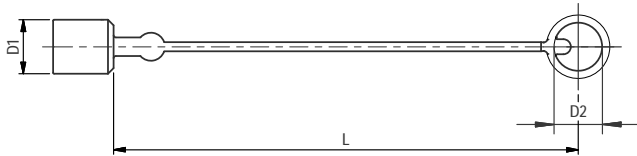

Series IB • Dust Protection

Dimensions (mm/in)			Material	Dust Cap for Male Tip	
D1	D2	L		Old Part Numbers	STAUFF Ordering Codes
18	23	240	Plastic (Colour: Red)	IB06-0-RT001	QRC-IB-06-DM-23-KI-RD
.71	.91	9.45			
23	24	240	Plastic (Colour: Red)	IB10-0-RT001	QRC-IB-10-DM-24-KI-RD
.91	.94	9.45			
29	28	245	Plastic (Colour: Red)	IB12-0-RT001	QRC-IB-12-DM-28-KI-RD
1.14	1.10	9.65			
36,0	38	245	Plastic (Colour: Red)	IB19-0-RT001	QRC-IB-19-DM-38-KI-RD
1.42	1.50	9.65			
44	44	253	Plastic (Colour: Red)	IB25-0-RT001	QRC-IB-25-DM-44-KI-RD
1.73	1.73	9.96			

Dimensions (mm/in)			Material	Dust Plug for Female Body	
D1	D2	L		Old Part Numbers	STAUFF Ordering Codes
26	23	240	Plastic (Colour: Red)	IB06-9-RT001	QRC-IB-06-DF-23-KI-RD
1.02	.91	9.45			
33	25	235	Plastic (Colour: Red)	IB10-9-RT001	QRC-IB-10-DF-25-KI-RD
1.30	.98	9.25			
38	29	240	Plastic (Colour: Red)	IB12-9-RT001	QRC-IB-12-DF-29-KI-RD
1.50	1.14	9.45			
49	38	240	Plastic (Colour: Red)	IB19-9-RT001	QRC-IB-19-DF-38-KI-RD
1.93	1.50	9.45			
60	46	245	Plastic (Colour: Red)	IB25-9-RT001	QRC-IB-25-DF-46-KI-RD
2.36	1.81	9.65			

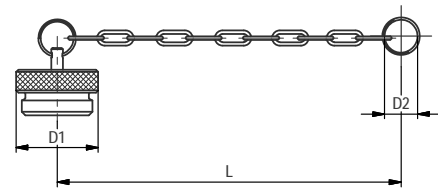
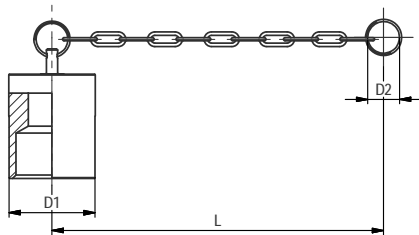

Dimensions (mm/in)			Material	Dust Cap for Male Tip	
D1	D2	L		Old Part Numbers	STAUFF Ordering Codes
22	28	245	Aluminium with chain	IB06-0-SI001	QRC-IB-06-DM-28/CN-W89-SI
.87	1.10	9.65			
27	30	155	Aluminium with chain	IB10-0-SI001	QRC-IB-10-DM-30/CN-W89-SI
1.06	1.18	6.10			
35	41	265	Aluminium with chain	IB12-0-SI001	QRC-IB-12-DM-41/CN-W89-SI
1.38	1.61	10.43			
42	30	250	Aluminium with chain	IB19-0-SI001	QRC-IB-19-DM-30/CN-W89-SI
1.65	1.18	9.84			
48	49	340	Aluminium with chain	IB25-0-SI001	QRC-IB-25-DM-49/CN-W89-SI
1.89	1.93	13.39			
55	46	225	Aluminium with chain	IB38-0-SI001	QRC-IB-38-DM-46/CN-W89-SI
2.17	1.81	8.86			
80	75	350	Aluminium with chain	IB51-0-SI001	QRC-IB-51-DM-75/CN-W89-SI
3.15	2.95	13.78			

Dimensions (mm/in)			Material	Dust Plug for Female Body	
D1	D2	L		Old Part Numbers	STAUFF Ordering Codes
22	30	210	Aluminium with chain	IB06-9-SI001	QRC-IB-06-DF-30/CN-W89-SI
.87	1.18	8.27			
22	30	155	Aluminium with chain	IB10-9-SI001	QRC-IB-10-DF-30/CN-W89-SI
.87	1.18	6.10			
28	41	305	Aluminium with chain	IB12-9-SI001	QRC-IB-12-DF-41/CN-W89-SI
1.10	1.61	12.01			
35	43	265	Aluminium with chain	IB19-9-SI001	QRC-IB-19-DF-43/CN-W89-SI
1.38	1.69	10.43			
44	41	240	Aluminium with chain	IB25-9-SI001	QRC-IB-25-DF-41/CN-W89-SI
1.73	1.61	9.45			
74	46	225	Aluminium with chain	IB38-9-SI001	QRC-IB-38-DF-46/CN-W89-SI
2.91	1.81	8.86			
105	75	350	Aluminium with chain	IB51-9-SI001	QRC-IB-51-DF-75/CN-W89-SI
4.13	2.95	13.78			

In addition to the standard colours as stated above, plastic dust caps are also available in blue, green, yellow and black. Please use the old color codes BL, GN, GE and SW respectively instead of RT. Please use the STAUFF codes BU, GN, YE and BK respectively instead of RD.



IB

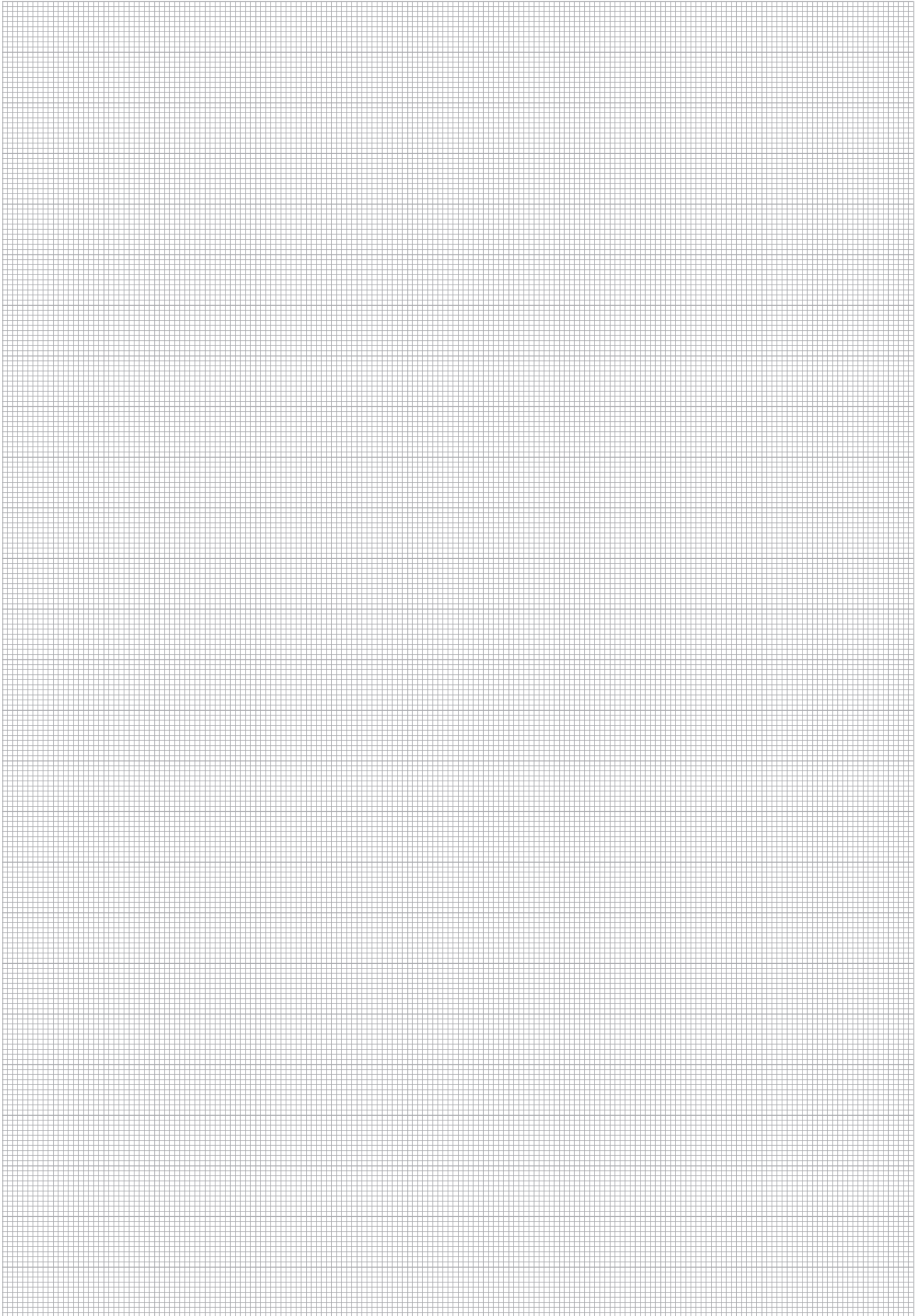

Series ID - Carbon Steel

Series ID - Overview	88
Series ID-06 - BG 1 - Nominal Size 6,3	89
Series ID-10 - BG 2 - Nominal Size 10	89
Series ID-19 - BG 6 - Nominal Size 19	89
Series ID-25 - BG 8 - Nominal Size 25	89
Series ID - Dust Protection	90



ID



Series ID • Carbon Steel

Material	Carbon Steel
Surface Finishing	Zinc-Nickel
Standard Seal Material(s)	NBR (Buna-N®) ²
Working Temperature	-25° C ... +100° C / -13° F ... +212° F
Valve Design	Poppet Valve
Connection	Push and actuate Push Sleeve
Disconnection	Actuate Push Sleeve
Connect Under Pressure	not allowed
Application	Industrial Hydraulic
ISO Interchange	-



²Alternative seal materials are available on request.

Technical Data

Series	BG	DN Zoll Inch	DN metric ISO 4397	Q _{max}		Working Pressure		Bursting Pressure Connected		Female Body		Male Tip		Spillage	
				l/min	US GPM	bar	PSI	bar	PSI	bar	PSI	bar	PSI	ml	fl oz
ID-06	1	1/4"	6,3	24	6.34	400	5801	1700	24656	1700	24656	1600	23206	1	.0338
ID-10	2	3/8"	10	46	12.15	350	5076	1500	21756	1700	24656	1500	21756	2,4	.0812
ID-19	6	3/4"	19 (20)	190	50.19	250	3626	1100	15954	1200	17404	1000	14504	8,6	.2908
ID-25	8	1"	25	250	66.04	250	3626	1000	14504	1100	15954	1200	17404	13,0	.4396

The indicated pressure ratings only apply to the coupling itself and depend on the connection type.

ID

Flow Characteristics

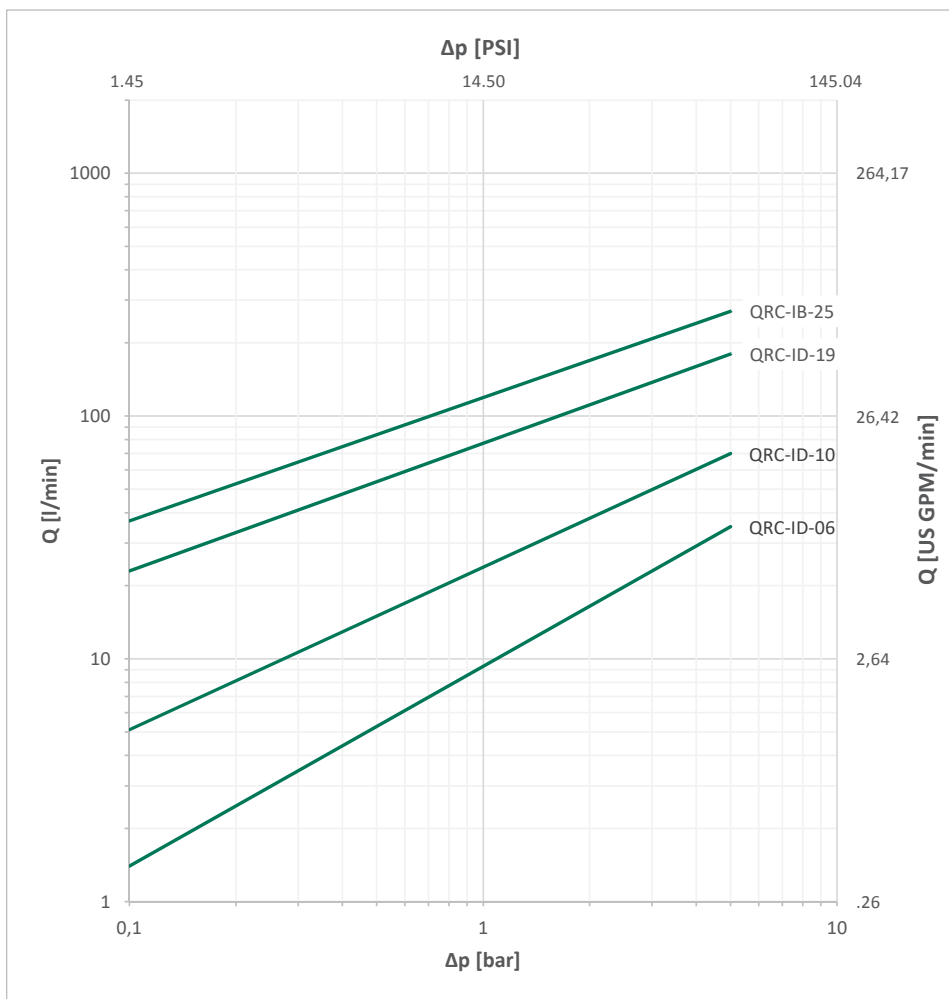

Please note: Unless otherwise stated, all flow characteristics have been determined with hydraulic oil with a kinematic viscosity of 28,8 - 35,2 mm²/s (28,8 - 35,2 cSt) and are only valid for components with non-reducing connections.



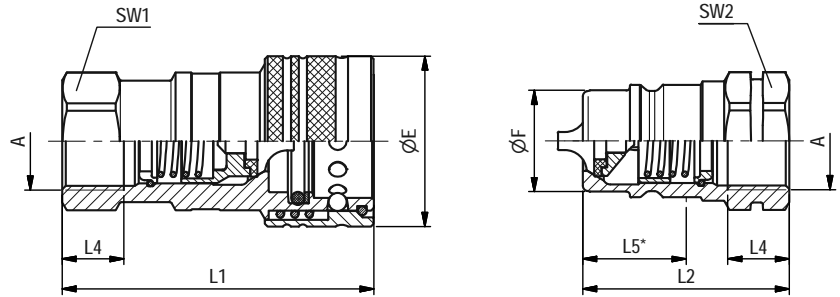

SW: Width across flats. All dimensions in mm (inch). Drawing similar Series ID-19.
* Insertion Male Tip.

Series ID-06 ▪ BG 1 ▪ Nominal Size 6,3

Port A	Dimensions (mm/in)							Female Body		Weight (^{kg} /lbs) ca. per 100	Male Tip		Weight (^{kg} /lbs) ca. per 100
	ØE	ØF	L1	L2	L4 min	L5	SW1	SW2	Old Part Numbers		Old Part Numbers		
Female Thread according to DIN 3852 - ANSI B 1.20.3													
	G 1/4"	27	14,2	55,5	38	12	17,2	19	19	ID06-1-IGF04	11,80	ID06-2-IGF04	4,60
		1.06	.56	2.19	1.50	.47	.68	.75	.75	QRC-ID-06-F-G04-BT-W3	26.01	QRC-ID-06-M-G04-B-W3	10.14
	NPTF 1/4" -18	27	14,2	55,5	38		17,2	19	19	ID06-1-INF04	11,90	ID06-2-INF04	4,70
		1.06	.56	2.19	1.50		.68	.75	.75	QRC-ID-06-F-NF04-BT-W3	26.24	QRC-ID-06-M-NF04-B-W3	10.36

Series ID-10 ▪ BG 2 ▪ Nominal Size 10

Port A	Dimensions (mm/in)							Female Body		Weight (^{kg} /lbs) ca. per 100	Male Tip		Weight (^{kg} /lbs) ca. per 100
	ØE	ØF	L1	L2	L4 min	L5	SW1	SW2	Old Part Numbers		Old Part Numbers		
Female Thread according to DIN 3852 - ANSI B 1.20.3													
	G 3/8"	27	19	63	42,5	12	20	24	24	ID10-1-IGF06	20	ID10-2-IGF06	8
		1.06	.75	2.48	1.67	.47	.79	.94	.94	QRC-ID-10-F-G06-BT-W3	44.09	QRC-ID-10-M-G06-B-W3	17.64
	NPTF 3/8" -18	27	19	63	42,5		20	24	24	ID10-1-INF06	20,10	ID10-2-INF06	8,10
		1.06	.75	2.48	1.67		.79	.94	.94	QRC-ID-10-F-NF06-BT-W3	44.31	QRC-ID-10-M-NF06-B-W3	17.86

Series ID-19 ▪ BG 6 ▪ Nominal Size 19

Port A	Dimensions (mm/in)							Female Body		Weight (^{kg} /lbs) ca. per 100	Male Tip		Weight (^{kg} /lbs) ca. per 100
	ØE	ØF	L1	L2	L4 min	L5	SW1	SW2	Old Part Numbers		Old Part Numbers		
Female Thread according to DIN 3852 - ANSI B 1.20.3													
	G 3/4"	47	28	86	57	16	28,5	34	34	ID19-1-IGF12	47,30	ID19-2-IGF12	18,30
		1.85	1.10	3.39	2.24	.63	1.12	1.34	1.34	QRC-ID-19-F-G12-BT-W3	104.28	QRC-ID-19-M-G12-B-W3	40.34
	NPTF 3/4" -14	47	28	86	57		28,5	34	34	ID19-1-INF12	47,80	ID19-2-INF12	18,80
		1.85	1.10	3.39	2.24		1.12	1.34	1.34	QRC-ID-19-F-NF12-BT-W3	105.38	QRC-ID-19-M-NF12-B-W3	41.45

Series ID-25 ▪ BG 8 ▪ Nominal Size 25

Port A	Dimensions (mm/in)							Female Body		Weight (^{kg} /lbs) ca. per 100	Male Tip		Weight (^{kg} /lbs) ca. per 100
	ØE	ØF	L1	L2	L4 min	L5	SW1	SW2	Old Part Numbers		Old Part Numbers		
Female Thread according to DIN 3852 - ANSI B 1.20.3													
	G 1"	52	31,3	99	65,5	18	33	41	41	ID25-1-IGF16	73,60	ID25-2-IGF16	28,20
		2.05	1.23	3.90	2.58	.71	1.30	1.61	1.61	QRC-ID-25-F-G16-BT-W3	162.26	QRC-ID-25-M-G16-B-W3	62.17
	NPTF 1" -11 1/2	52	31,3	99	65,5		33	41	41	ID25-1-INF16	74,30	ID25-2-INF16	28,90
		2.05	1.23	3.90	2.58		1.30	1.61	1.61	QRC-ID-25-F-NF16-BT-W3	163.80	QRC-ID-25-M-NF16-B-W3	63.71

Note: The connection of the two halves of a coupling is achieved depending on the type. It is important to observe the positive engagement of plug-type couplings and the secure tightening of screw-type couplings to the limit stop of the thread. Forced or improper separation will result in malfunction of the coupling.



Series ID ▪ Dust Protection

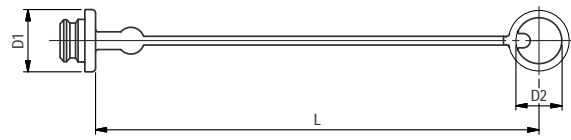
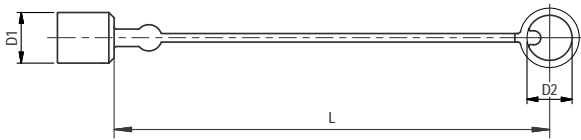

Dimensions (mm/in)			Material	Dust Cap for Male Tip	
D1	D2	L		Old Part Numbers	STAUFF Ordering Codes
22	25	210	Plastic (Colour: Red)	ID06-0-RT001	QRC-ID-06-DM-25-KI-RD
.87	.98	8.27			
27	24	205	Plastic (Colour: Red)	ID10-0-RT001	QRC-ID-10-DM-24-KI-RD
1.06	.94	8.07			
37	33	270	Plastic (Colour: Red)	ID19-0-RT001	QRC-ID-19-DM-33-KI-RD
1.46	1.30	10.63			
41,0	39	290	Plastic (Colour: Red)	ID25-0-RT001	QRC-ID-25-DM-39-KI-RD
1.61	1.54	11.42			

Dimensions (mm/in)			Material	Dust Plug for Female Body	
D1	D2	L		Old Part Numbers	STAUFF Ordering Codes
25	18	205	Plastic (Colour: Red)	ID06-9-RT001	QRC-ID-06-DF-18-KI-RD
.98	.71	8.07			
30	24	235	Plastic (Colour: Red)	ID10-9-RT001	QRC-ID-10-DF-24-KI-RD
1.18	.94	9.25			
44	33	270	Plastic (Colour: Red)	ID19-9-RT001	QRC-ID-19-DF-33-KI-RD
1.73	1.30	10.63			
50	39	290	Plastic (Colour: Red)	ID25-9-RT001	QRC-ID-25-DF-39-KI-RD
1.97	1.54	11.42			

In addition to the standard colours as stated above, plastic dust caps are also available in blue, green, yellow and black. Please use the old color codes BL, GN, GE and SW respectively instead of RT. Please use the STAUFF codes BU, GN, YE and BK respectively instead of RD.

ID



Series BP • Carbon Steel

Series BP • Overview	92
Series BP-12 • BG 3 • Nominal Size 12,5	93
Series BP • Dust Protection	93

**BP**

Series BP ▪ Carbon Steel

Material	Carbon Steel
Surface Finishing	Zinc-Nickel
Standard Seal Material(s)	NBR (Buna-N®), PTFE ²
Working Temperature	-25° C ... +100° C / -13° F ... +212° F
Valve Design	Flat Face
Connection	Push and actuate Push Sleeve
Disconnection	Actuate Push Sleeve
Connect Under Pressure	not allowed
Application	Agricultural and Forestry Machinery
ISO Interchange	ISO 5676



²Alternative seal materials are available on request.

Technical Data

Series	BG	DN Zoll Inch	DN metric ISO 4397	Q _{max}		Working Pressure		Bursting Pressure Connected		Female Body		Male Tip		Spillage	
				l/min	US GPM	bar	PSI	bar	PSI	bar	PSI	bar	PSI	ml	fl oz
BP-12	3	1/2"	12,5	70	18.49	150	2175	930	13489	620	8992	900	13053	0,05	.0017

The indicated pressure ratings only apply to the coupling itself and depend on the connection type.

BP

Flow Characteristics

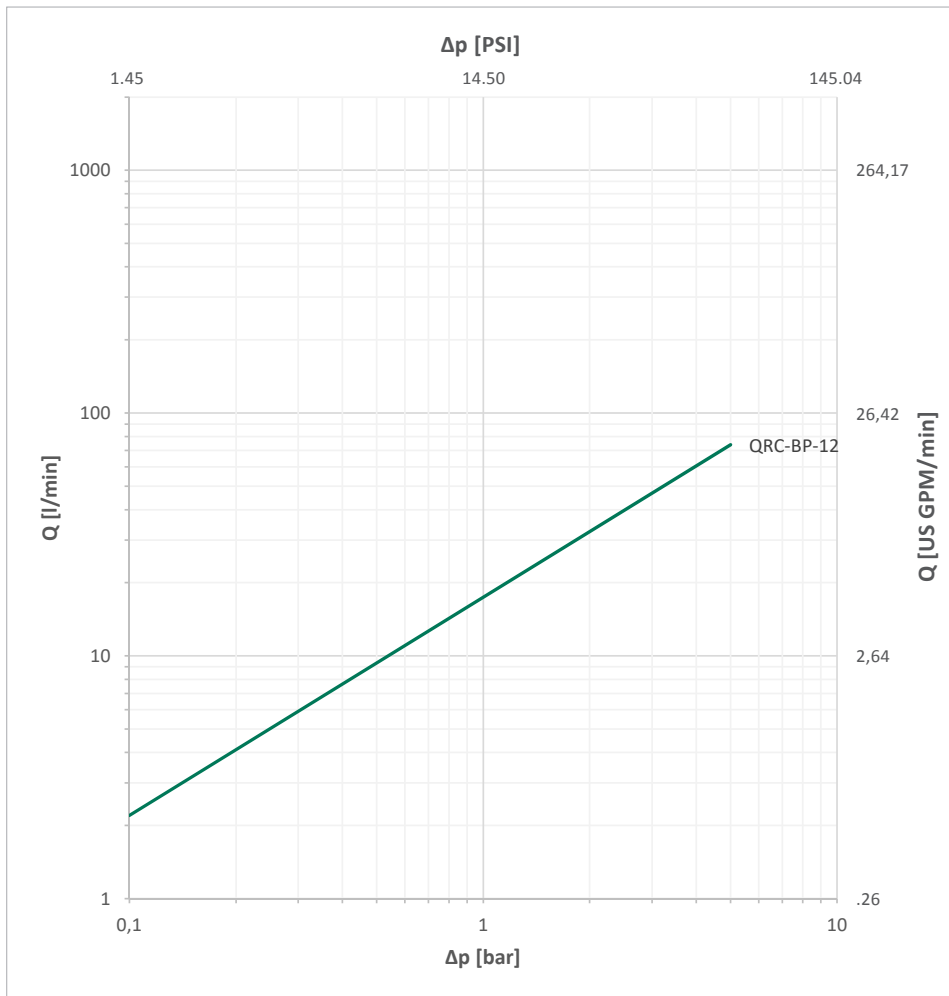



Please note: Unless otherwise stated, all flow characteristics have been determined with hydraulic oil with a kinematic viscosity of 28,8 - 35,2 mm²/s (28,8 - 35,2 cSt) and are only valid for components with non-reducing connections.

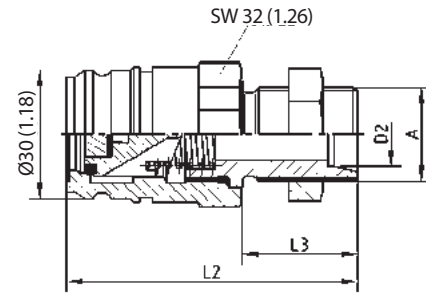
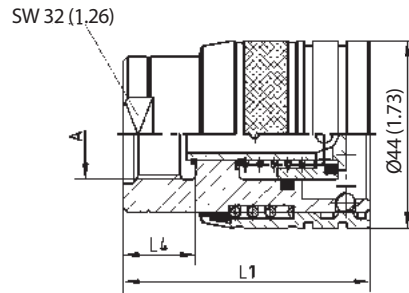

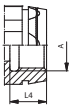

SW: Width across flats. All dimensions in mm (inch).

Series BP-12 • BG 3 • Nominal Size 12,5

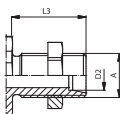
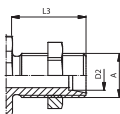
Port A	Dimensions (^{mm} / _{in})					Female Body		Weight (^{kg} / _{lbs}) ca. per 100	Male Tip		Weight (^{kg} / _{lbs}) ca. per 100
	ØD2	L1	L2	L3	L4	Old Part Numbers	STAUFF Ordering Codes		Old Part Numbers	STAUFF Ordering Codes	
Female Thread according to DIN 3852											
 G 1/2"		55,5			15	BP10-1-IGF08		38,90			
		2.19			.59	QRC-BP-12-F-G08-BT-W3		85.76			
 M18x1,5		55,5			15	BP10-1-IMF18		40,20			
		2.19			.59	QRC-BP-12-F-M180R-BT-W3		88.63			
Male Thread with 24° Conical Bore - Bulkhead - Shape W according to DIN 3861											
 M18x1,5	12L		49	21					BP10-2-N1218		14,20
			1.93	.83					QRC-BP-12-M-12LB-B-W3		31.31
 M22x1,5	15L		51	23					BP10-2-N1522		17,20
			2.01	.91					QRC-BP-12-M-15LB-B-W3		37.92

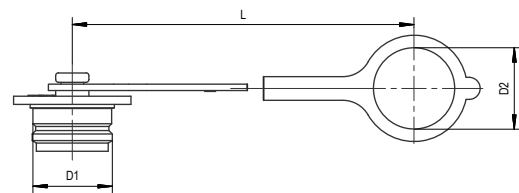
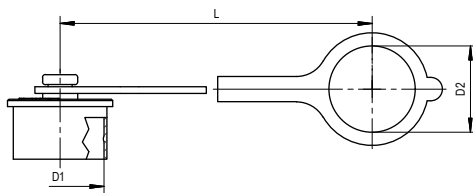
BP
Series BP • Dust Protection

Dimensions (^{mm} / _{in})			Material	Dust Cap for Male Tip	
D1	D2	L		Old Part Numbers	STAUFF Ordering Codes
30	29,5	185	Plastic (Colour: Red)	BP10-0-RT001	
1.18	1.16	7.28		QRC-BP-10-DM-30-K-RD	

Dimensions (^{mm} / _{in})			Material	Dust Plug for Female Body	
D1	D2	L		Old Part Numbers	STAUFF Ordering Codes
29	29,5	185	Plastic (Colour: Red)	BP10-9-RT001	
1.14	1.16	7.28		QRC-BP-10-DF-30-K-RD	

Note: The connection of the two halves of a coupling is achieved depending on the type. It is important to observe the positive engagement of plug-type couplings and the secure tightening of screw-type couplings to the limit stop of the thread. Forced or improper separation will result in malfunction of the coupling.



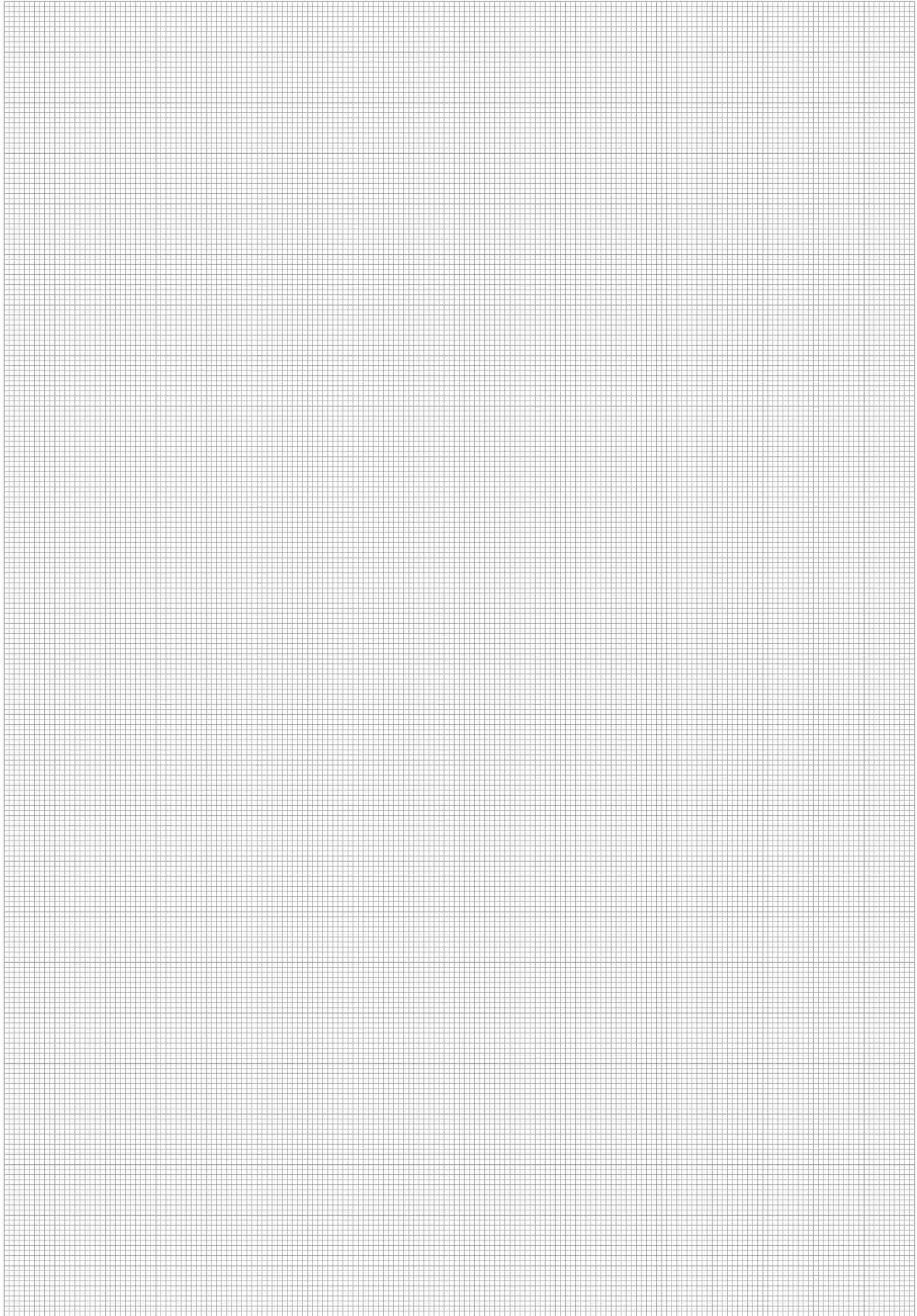

BP



Series HC • Carbon Steel

Series HC • Overview	96
Series HC-06 • BG 1 • Nominal Size 6,3	97
Series HC • Dust Protection	97



HC



Series HC ▪ Carbon Steel

Material	Carbon Steel
Surface Finishing	Zinc-Plating and Thick-Film-Passivation (Chrome III)
Standard Seal Material(s)	Special compound ²
Working Temperature	-35° C ... +130° C / -31° F ... +266° F
Valve Design	Flat Face
Connection	Push and actuate Push Sleeve
Disconnection	Actuate Push Sleeve
Connect Under Pressure	not allowed
Application	Rescue and Tensioning Hydraulics
ISO Interchange	-



²Alternative seal materials are available on request.

Technical Data

Series	BG	DN Zoll Inch	DN metric ISO 4397	Q _{max}		Working Pressure		Bursting Pressure Connected		Female Body		Male Tip		Spillage	
				l/min	US GPM	bar	PSI	bar	PSI	bar	PSI	bar	PSI	ml	fl oz
HC-06	1	1/4"	6,3	6	1.58	1000	14504	2500	36259	2500	36259	2500	36259	0,008	.0003

The indicated pressure ratings only apply to the coupling itself and depend on the connection type.

HC

Flow Characteristics

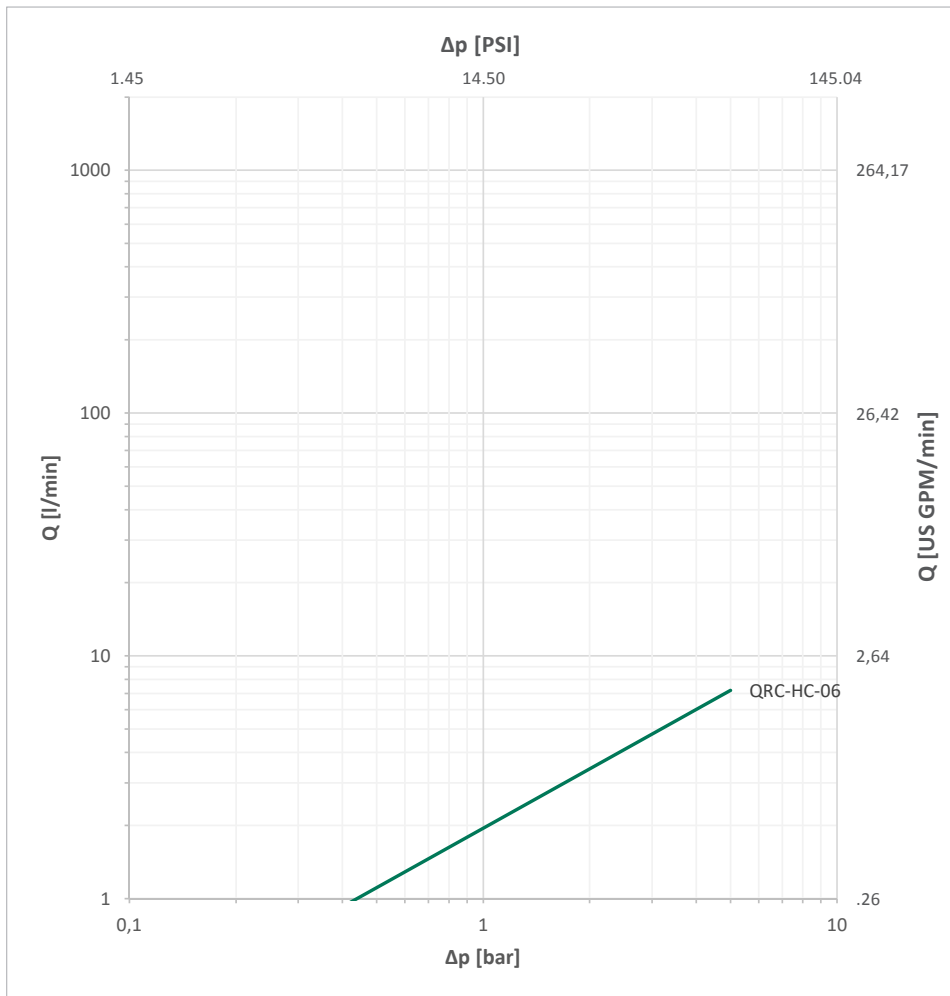

Please note: Unless otherwise stated, all flow characteristics have been determined with hydraulic oil with a kinematic viscosity of 28,8 - 35,2 mm²/s (28,8 - 35,2 cSt) and are only valid for components with non-reducing connections.



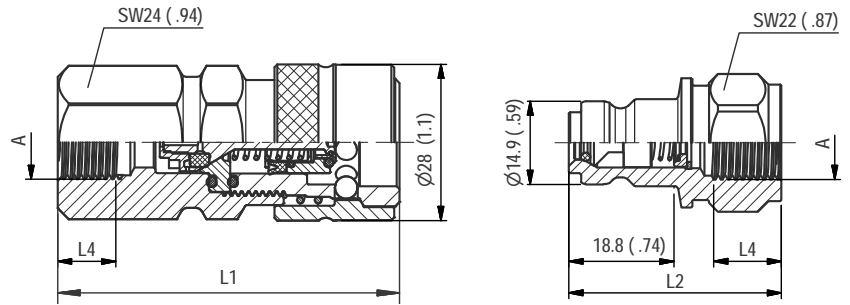

SW: Width across flats. All dimensions in mm (inch).

Series HC-06 • BG 1 • Nominal Size 6,3

Port A	Dimensions (mm/in)					Female Body	Weight	Male Tip	Weight
	ØD2	L1	L2	L3	L4 min	Old Part Numbers STAUFF Ordering Codes	(kg/lbs) ca. per 100	Old Part Numbers STAUFF Ordering Codes	(kg/lbs) ca. per 100
Female Thread according to DIN 3852 - ANSI B 1.20.3									
	G 1/8"	54,3	38,1		8	HC06-1-IGF02	17,60	HC06-2-IGF02	7,80
		2.14	1.50		0.31	QRC-HC-06-F-G02-Y-W66	38.80	QRC-HC-06-M-G02-Y-W66	17.20
	G 1/4"	61,3	38,1		12	HC06-1-IGF04	19,50	HC06-2-IGF04	7,10
		2.41	1.50		0.47	QRC-HC-06-F-G04-Y-W66	42.99	QRC-HC-06-M-G04-Y-W66	15.65
	NPTF 1/4" -18	58,3	35,7			HC06-1-INF04	18,60	HC06-2-INF04	6,70
		2.30	1.41			QRC-HC-06-F-NF04-Y-W66	41.01	QRC-HC-06-M-NF04-Y-W66	14.77
	G 3/8"	63,3	39,6		12	HC06-1-IGF06	19,30	HC06-2-IGF06	8,40
		2.49	1.56		0.47	QRC-HC-06-F-G06-Y-W66	42.55	QRC-HC-06-M-G06-Y-W66	18.52
	NPTF 3/8" -18	60,3	39,6			HC06-1-INF06	18,50	HC06-2-INF06	7,80
		2.37	1.56			QRC-HC-06-F-NF06-Y-W66	40.79	QRC-HC-06-M-NF06-Y-W66	17.20

Series HC • Dust Protection

Dimensions (mm/in)			Material	Dust Cap for Male Tip
D1	D2	L		Old Part Numbers STAUFF Ordering Codes
29	22,5	110	Plastic (Colour: Red)	HC06-0-RT001
1.14	.89	4.33		QRC-HC-06-DM-23-KI-RD

Dimensions (mm/in)			Material	Dust Plug for Female Body
D1	D2	L		Old Part Numbers STAUFF Ordering Codes
29	20,5	110	Plastic (Colour: Red)	HC06-9-RT001
1.14	.81	4.33		QRC-HC-06-DF-21-KI-RD

In addition to the standard colours as stated above, plastic dust caps are also available in blue, green, yellow and black. Please use the old color codes BL, GN, GE and SW respectively instead of RT. Please use the STAUFF codes BU, GN, YE and BK respectively instead of RD.

Note: The connection of the two halves of a coupling is achieved depending on the type. It is important to observe the positive engagement of plug-type couplings and the secure tightening of screw-type couplings to the limit stop of the thread. Forced or improper separation will result in malfunction of the coupling.



HC

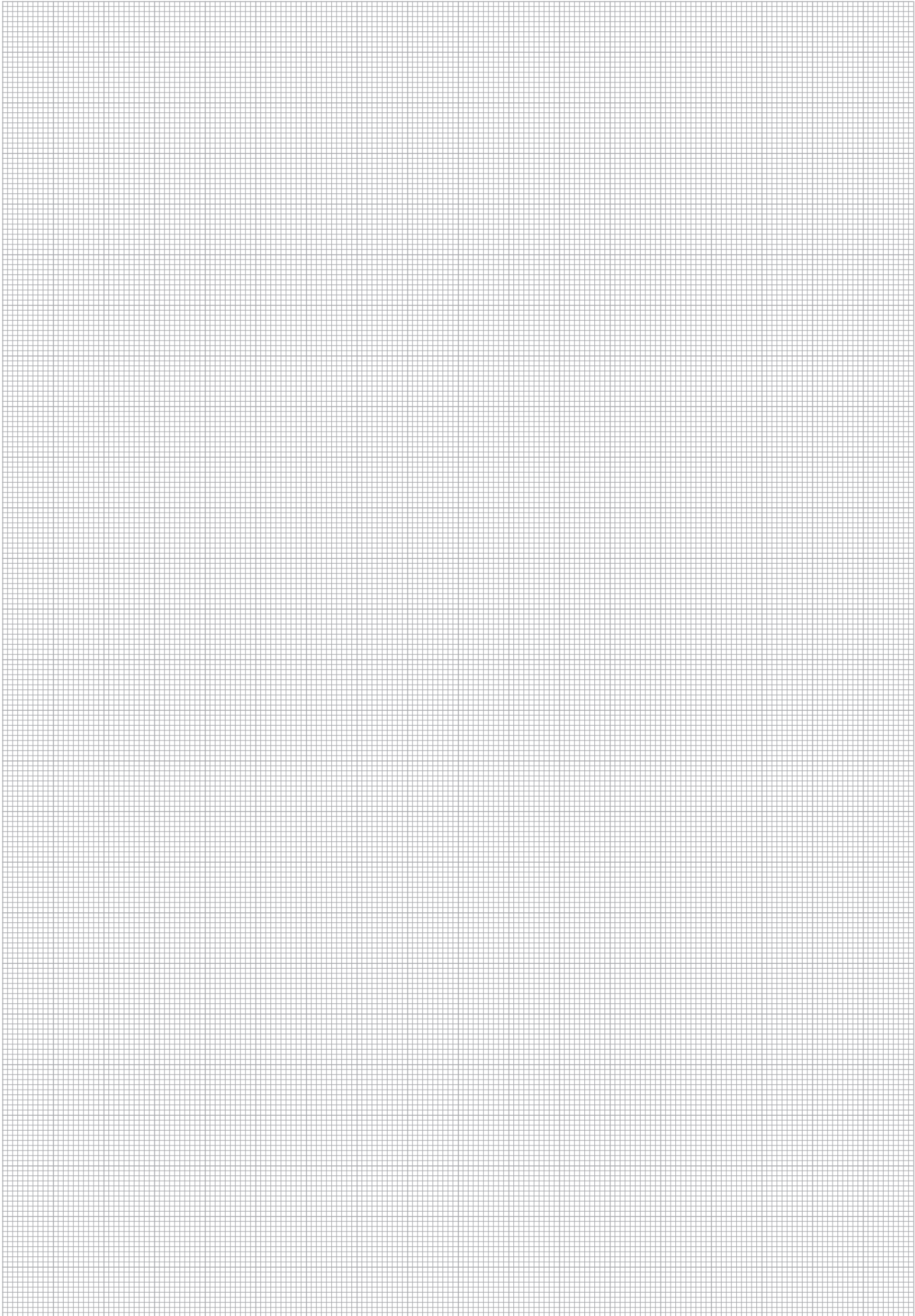

Series HD • Carbon Steel

Series HD • Overview	100
Series HD-06 • BG 1 • Nominal Size 6,3	101
Series HD • Dust Protection	101



HD



Series HD ▪ Carbon Steel

Material	Carbon Steel
Surface Finishing	Zinc-Plating and Thick-Film-Passivation (Chrome III)
Standard Seal Material(s)	Special compound ²
Working Temperature	-35° C ... +130° C / -31° F ... +266° F
Valve Design	Flat Face
Connection	Push and actuate Push Sleeve
Disconnection	Actuate Push Sleeve
Connect Under Pressure	not allowed
Application	Rescue and Tensioning Hydraulics
ISO Interchange	-



²Alternative seal materials are available on request.

Technical Data

Series	BG	DN Zoll Inch	DN metric ISO 4397	Q _{max}		Working Pressure		Bursting Pressure Connected		Female Body		Male Tip		Spillage	
				l/min	US GPM	bar	PSI	bar	PSI	bar	PSI	bar	PSI	ml	fl oz
HD-06	1	1/4"	6,3	6	1.58	1500	21756	3500	50763	3500	50763	3500	50763	0,008	.0003

The indicated pressure ratings only apply to the coupling itself and depend on the connection type.

HD

Flow Characteristics

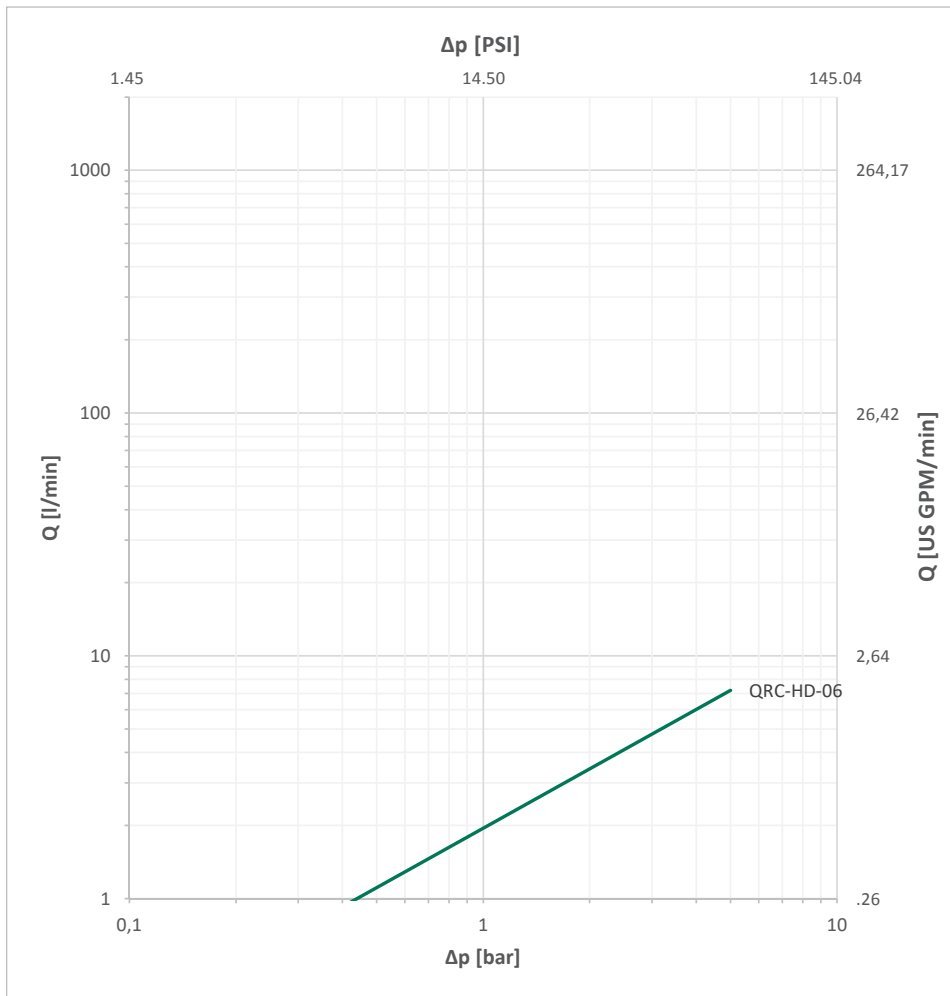

Please note: Unless otherwise stated, all flow characteristics have been determined with hydraulic oil with a kinematic viscosity of 28,8 - 35,2 mm²/s (28,8 - 35,2 cSt) and are only valid for components with non-reducing connections.



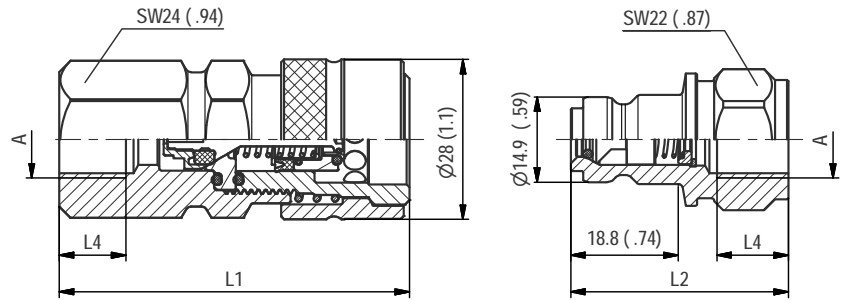

SW: Width across flats. All dimensions in mm (inch).

Series HD-06 ■ BG 1 ■ Nominal Size 6,3

Port A	Dimensions (mm/in)					Female Body	Weight	Male Tip	Weight
	$\varnothing D2$	L1	L2	L3	L4 min	Old Part Numbers STAUFF Ordering Codes	(^{kg} /lbs) ca. per 100	Old Part Numbers STAUFF Ordering Codes	(^{kg} /lbs) ca. per 100
Female Thread according to DIN 3852 - ANSI B 1.20.3									
	G 1/4"	61,3	38,1		12	HD06-1-IGF04	19,60	HD06-2-IGF04	7,10
	NPTF 1/4" -18	2.41	1.50		0.47	QRC-HD-06-F-G04-Y-W66	43.21	QRC-HD-06-M-G04-Y-W66	15.65
		58,3	35,7			HD06-1-INF04	18,60	HD06-2-INF04	6,60
		2.30	1.41			QRC-HD-06-F-NF04-Y-W66	41.01	QRC-HD-06-M-NF04-Y-W66	14.55

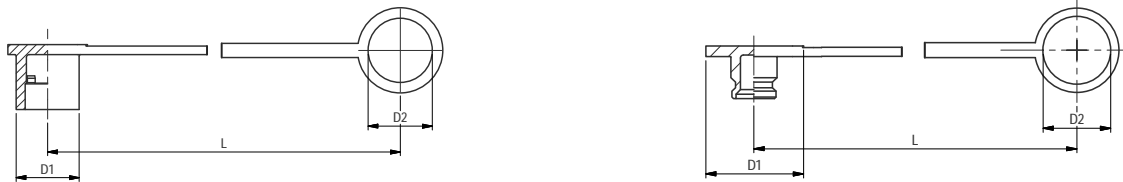
Series HD ■ Dust Protection

HD

Dimensions (mm/in)			Material	Dust Cap for Male Tip
D1	D2	L		Old Part Numbers STAUFF Ordering Codes
29	22,5	110	Plastic (Colour: Black)	HD06-0-SW001
1.14	.89	4.33		QRC-HD-06-DM-23-KI-BK

Dimensions (mm/in)			Material	Dust Plug for Female Body
D1	D2	L		Old Part Numbers STAUFF Ordering Codes
29	20,5	110	Plastic (Colour: Black)	HD06-9-SW001
1.14	.81	4.33		QRC-HD-06-DF-21-KI-BK

Note: The connection of the two halves of a coupling is achieved depending on the type. It is important to observe the positive engagement of plug-type couplings and the secure tightening of screw-type couplings to the limit stop of the thread. Forced or improper separation will result in malfunction of the coupling.



HD

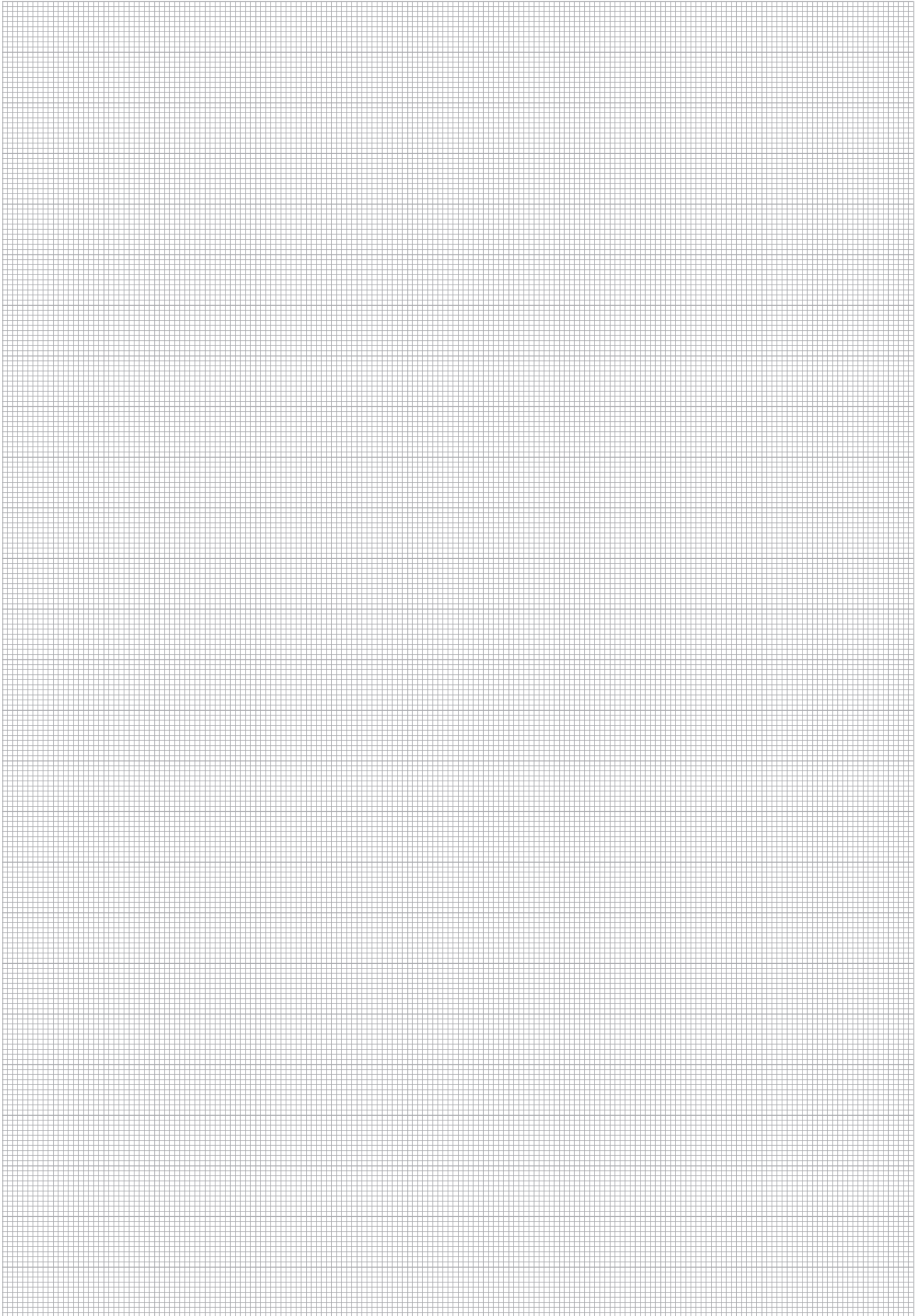

Series HUS - Carbon Steel

Series HUS - Overview	104
Series HUS-10 - BG 2 - Nominal Size 10	105
Series HUS-12 - BG 3 - Nominal Size 12,5	105
Series HUS-19 - BG 6 - Nominal Size 19	105
Series HUS-25 - BG 8 - Nominal Size 25	105



HUS



Series HUS - Carbon Steel

Material	Carbon Steel
Surface Finishing	Zinc-Nickel
Standard Seal Material(s)	NBR (Buna-N®) ²
Working Temperature	-40° C ... +106° C / -40° F ... +223° F
Valve Design	Poppet Valve
Connection	Push
Disconnection	Actuate Push Sleeve
Connect Under Pressure	Male Tip/Female Body
Application	Construction Machinery, Industrial Hydraulic
ISO Interchange	-



²Alternative seal materials are available on request.

Technical Data

Series	BG	DN Zoll Inch	DN metric ISO 4397	Q _{max}		Working Pressure		Bursting Pressure Connected		Female Body		Male Tip		Spillage	
				l/min	US GPM	bar	PSI	bar	PSI	bar	PSI	bar	PSI	ml	fl oz
HUS-10	2	3/8"	10			350	5075	1500	21750	1450	21025	1500	21750		
HUS-12	3	1/2"	12,5			315	4567.5	1300	18850	1200	17400	1250	18125		
HUS-19	6	3/4"	19 (20)			300	4350	1250	18125	1200	17400	1250	18125		
HUS-25	8	1"	25			260	3770	1100	15950	1000	14500	1100	15950		

The indicated pressure ratings only apply to the coupling itself and depend on the connection type.

Flow Characteristics

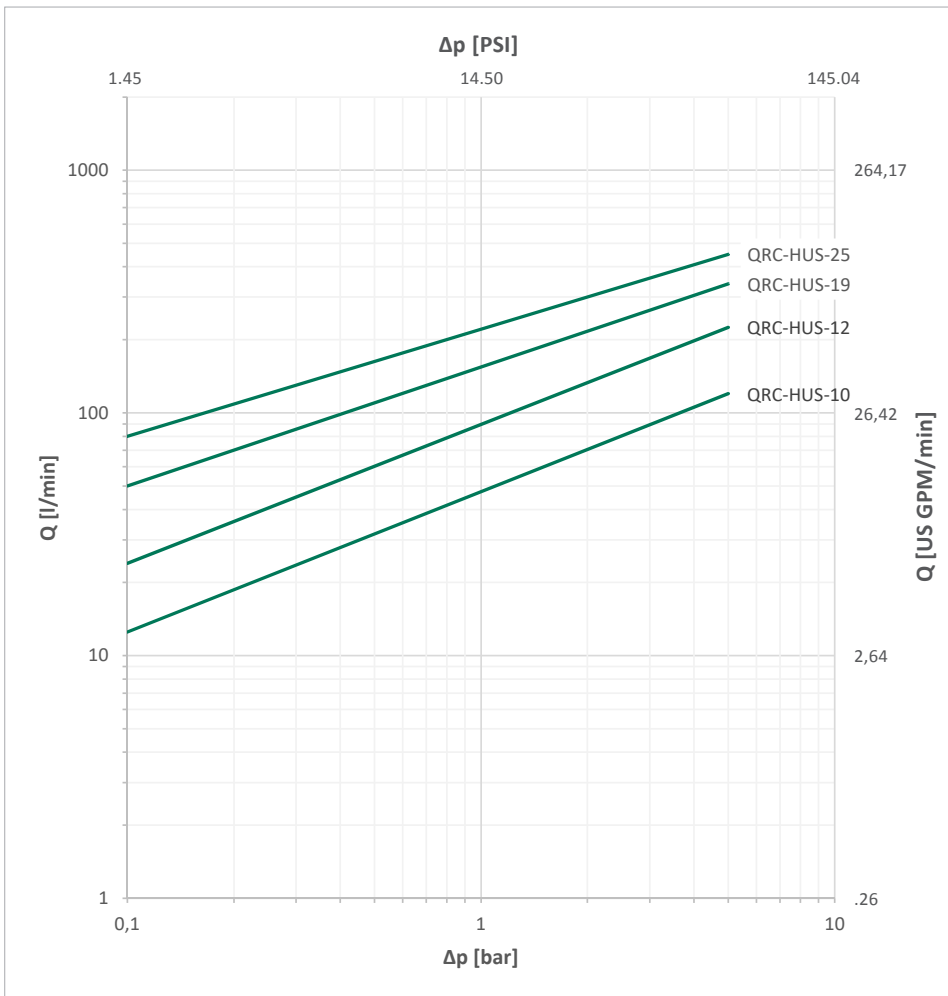

Please note: Unless otherwise stated, all flow characteristics have been determined with hydraulic oil with a kinematic viscosity of 28,8 - 35,2 mm²/s (28,8 - 35,2 cSt) and are only valid for components with non-reducing connections.



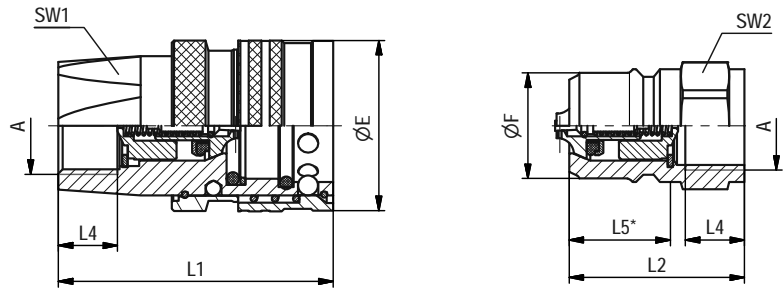

SW: Width across flats. All dimensions in mm (inch).

Series HUS-10 • BG 2 • Nominal Size 10

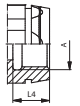
Port A	Dimensions (^{mm} / _{in})								Female Body		Weight (*9 _{lbs}) ca. per 100	Male Tip		Weight (*9 _{lbs}) ca. per 100
	ØE	ØF	L1	L2	L4 min	L5	SW1	SW2	Old Part Numbers	STAUFF Ordering Codes		Old Part Numbers	STAUFF Ordering Codes	
Female Thread according to DIN 3852 - ANSI B 1.20.3														
 G 3/8"	34	20	60	38	12	23	24	22	HUS10-1-IGF06	224,7	HUS10-2-IGF06	60		
	1.3	.8	2.4	1.5	.47	.91	.9	.9	QRC-HUS-10-F-G06-BT-W3	495,38	QRC-HUS-10-M-G06-B-W3	132,28		

Series HUS-12 • BG 3 • Nominal Size 12,5

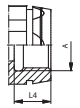
Port A	Dimensions (^{mm} / _{in})								Female Body		Weight (*9 _{lbs}) ca. per 100	Male Tip		Weight (*9 _{lbs}) ca. per 100
	ØE	ØF	L1	L2	L4 min	L5	SW1	SW2	Old Part Numbers	STAUFF Ordering Codes		Old Part Numbers	STAUFF Ordering Codes	
Female Thread according to DIN 3852 - ANSI B 1.20.3														
 G 1/2"	40	25	65,5	41,5	14	24,5	30	27	HUS12-1-IGF08	317,68	HUS12-2-IGF08	105,45		
	1.6	1.0	2.6	1.6	.55	.96	1.2	1.1	QRC-HUS-12-F-G08-BT-W3	700,36	QRC-HUS-12-M-G08-B-W3	232,48		

HUS
Series HUS-19 • BG 6 • Nominal Size 19

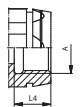
Port A	Dimensions (^{mm} / _{in})								Female Body		Weight (*9 _{lbs}) ca. per 100	Male Tip		Weight (*9 _{lbs}) ca. per 100
	ØE	ØF	L1	L2	L4 min	L5	SW1	SW2	Old Part Numbers	STAUFF Ordering Codes		Old Part Numbers	STAUFF Ordering Codes	
Female Thread according to DIN 3852 - ANSI B 1.20.3														
 G 3/4"	52	33	74,5	46,5	16	28,5	38	36	HUS19-1-IGF12	585	HUS19-2-IGF12	185		
	2.0	1.3	2.9	1.8	.63	1.12	1.5	1.4	QRC-HUS-19-F-G12-BT-W3	1289,70	QRC-HUS-19-M-G12-B-W3	407,86		

Series HUS-25 • BG 8 • Nominal Size 25

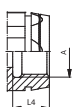
Port A	Dimensions (^{mm} / _{in})								Female Body		Weight (*9 _{lbs}) ca. per 100	Male Tip		Weight (*9 _{lbs}) ca. per 100
	ØE	ØF	L1	L2	L4 min	L5	SW1	SW2	Old Part Numbers	STAUFF Ordering Codes		Old Part Numbers	STAUFF Ordering Codes	
Female Thread according to DIN 3852 - ANSI B 1.20.3														
 G 1"	62	41	88,5	54,5	18	35	45	46	HUS25-1-IGF16	939	HUS25-2-IGF16	339		
	2.4	1.6	3.5	2.1	.71	1.38	1.8	1.8	QRC-HUS-25-F-G16-BT-W3	2070,14	QRC-HUS-25-M-G16-B-W3	747,37		

Note: The connection of the two halves of a coupling is achieved depending on the type. It is important to observe the positive engagement of plug-type couplings and the secure tightening of screw-type couplings to the limit stop of the thread. Forced or improper separation will result in malfunction of the coupling.





Series MK

Series MK - Overview	108
Series MK-Q-10/4 - BG 2 - Nominal Size 10	109
Series MK-R-10/4 - BG 2 - Nominal Size 10	110

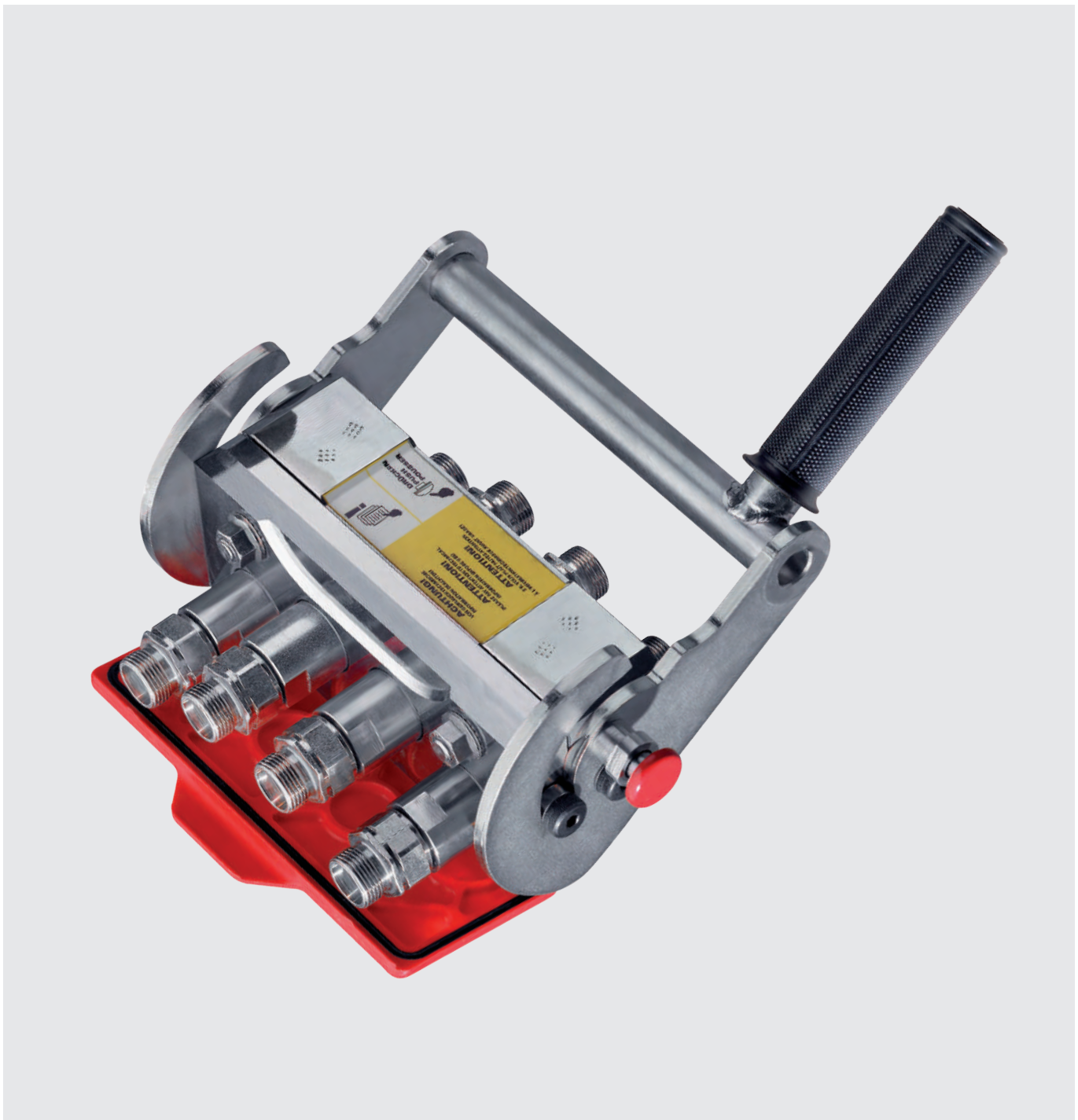

MK



Series MK

Description

The multi-coupling has been created for connecting and disconnecting several hydraulic lines at the same time. This is done by an operating lever the guide crank of which is designed for a minimum of operating force.

The connection of the hydraulic lines is done with flat face couplings. Due to the special sealing it is possible to couple against trapped pressure on the male halves (max. 4x100 bar / 4x1450 PSI)

The main features of the multi coupling are:

- Safety against commutability of hydraulic lines
- Quick connecting
- Coupling against trapped pressure
- Optimally minimized spillage during coupling process

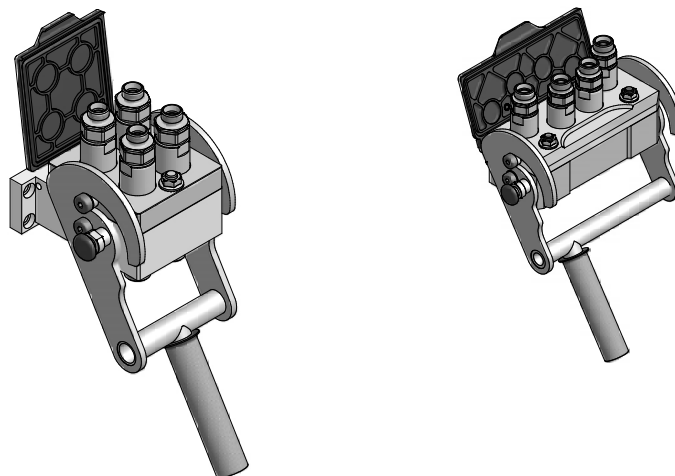

Spare Parts

The following list shows the spare parts available for the line of the multi-coupling products. They are supplied in form of kits, including detailed removal and installation instructions:

Description	MK 24	MK 74
	Old Part Numbers	Old Part Numbers
	STAUFF Ordering Codes	STAUFF Ordering Codes
Operating lever kit	MU20-1-KIT001	MU70-1-KIT001
	QRC-MK-Q-10/4-SP-OL-W3	QRC-MK-R-10/4-SP-OL-W3
Safety lock kit	MU20-1-KIT002	MU20-1-KIT002
	QRC-MK-Q-10/4-SP-SL-W3	QRC-MK-Q-10/4-SP-SL-W3
Dust protection kit	MU20-1-KIT003	MU70-1-KIT004
	QRC-MK-Q-10/4-SP-DP-K	QRC-MK-R-10/4-SP-DP-K
Female coupling	EK08-1-XXXX*	EK08-1-XXXX*
	QRC-EK-10-F-XXX-BT-W3	QRC-EK-10-F-XXX-BT-W3
Centering bolt kit	MU20-2-KIT001	MU20-2-KIT001
	QRC-MK-Q-10/4-SP-CB-W3	QRC-MK-Q-10/4-SP-CB-W3
Guide screw kit	MU20-2-KIT002	MU20-2-KIT002
	QRC-MK-Q-10/4-SP-GS-W4	QRC-MK-Q-10/4-SP-GS-W4
Male coupling	EK08-2-XXXX*	EK08-2-XXXX*
	QRC-EK-10-M-XXX-BP-W3	QRC-EK-10-M-XXX-BP-W3
Seal kit (20 pcs.)	MU20-2-KIT003	MU20-2-KIT003
	QRC-EK-10-MSK-PU	QRC-EK-10-MSK-PU

MK

Note: The connection of the two halves of a coupling is achieved depending on the type. It is important to observe the positive engagement of plug-type couplings and the secure tightening of screw-type couplings to the limit stop of the thread. Forced or improper separation will result in malfunction of the coupling.



Working Pressure

250 bar / 25 MPa / 3626 PSI (2 x 250 bar, 2 x 40 bar)

Material

Steel

Surface Finishing

Zinc-Nickel

Standard Seal Material(s)

NBR (Buna-N®), PTFE, PU

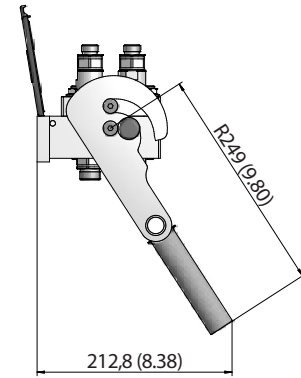
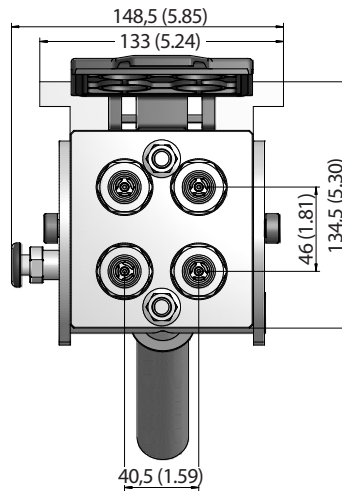

SW: Width across flats. All dimensions in mm (inch).

Series MK-Q-10/4 24 · BG 2 · Nominal Size 10

	Port A	Dimensions (mm/in)	Fixed half		Weight (kg/lbs) ca. per 100	Mobile half		Multicoupling System Old Part Numbers STAUFF Ordering Codes	Weight (kg/lbs) ca. per 100	
			Old Part Numbers	STAUFF Ordering Codes		Old Part Numbers	STAUFF Ordering Codes			
Female Thread according to DIN 3852-2-A - ANSI B 1.20.3										
	G 3/8"		MK24-1-IGF06		581	MK24-2-IGF06		283	MK24-8-IGF06	864
			QRC-MK-Q-10/4-FP-G06-BT-W3	1280.89	QRC-MK-Q-10/4-MP-G06-BP-W3	623.91	QRC-MK-Q-10/4-CC-G06-S1-W3	1904.79		
	G 1/2"		MK24-1-IGF08		581	MK24-2-IGF08		283	MK24-8-IGF08	864
			QRC-MK-Q-10/4-FP-G08-BT-W3	1280.89	QRC-MK-Q-10/4-MP-G08-BP-W3	623.91	QRC-MK-Q-10/4-CC-G08-S1-W3	1904.79		
	NPTF 1/2" -14		MK24-1-INF08		581	MK24-2-INF08		283	MK24-8-INF08	864
			QRC-MK-Q-10/4-FP-NF08-BT-W3	1280.89	QRC-MK-Q-10/4-MP-NF08-BP-W3	623.91	QRC-MK-Q-10/4-CC-NF08-S1-W3	1904.79		
Male Thread with 24° Conical Bore - Shape W according to DIN 3861										
	M16x1,5	10L	MK24-1-L1016		557	MK24-2-L1016		259	MK24-8-L1016	816
			QRC-MK-Q-10/4-FP-10L-BT-W3	1227.98	QRC-MK-Q-10/4-MP-10L-BP-W3	571.00	QRC-MK-Q-10/4-CC-10L-S1-W3	1798.97		
	M18x1,5	12L	MK24-1-L1218		565	MK24-2-L1218		259	MK24-8-L1218	824
			QRC-MK-Q-10/4-FP-12L-BT-W3	1245.61	QRC-MK-Q-10/4-MP-12L-BP-W3	571.00	QRC-MK-Q-10/4-CC-12L-S1-W3	1816.61		
	M22x1,5	15L	MK24-1-L1522		565	MK24-2-L1522		267	MK24-8-L1522	832
			QRC-MK-Q-10/4-FP-15L-BT-W3	1245.61	QRC-MK-Q-10/4-MP-15L-BP-W3	588.63	QRC-MK-Q-10/4-CC-15L-S1-W3	1834.25		
	M26x1,5	18L	MK24-1-L1826		581	MK24-2-L1826		267	MK24-8-L1826	848
			QRC-MK-Q-10/4-FP-18L-BT-W3	1280.89	QRC-MK-Q-10/4-MP-18L-BP-W3	588.63	QRC-MK-Q-10/4-CC-18L-S1-W3	1869.25		

MK

Note: The connection of the two halves of a coupling is achieved depending on the type. It is important to observe the positive engagement of plug-type couplings and the secure tightening of screw-type couplings to the limit stop of the thread. Forced or improper separation will result in malfunction of the coupling.



Working Pressure

250 bar / 25 MPa / 3626 PSI (2 x 250 bar, 2 x 40 bar)

Material

Steel

Surface Finishing

Zinc-Nickel

Standard Seal Material(s)

NBR (Buna-N®), PTFE, PU

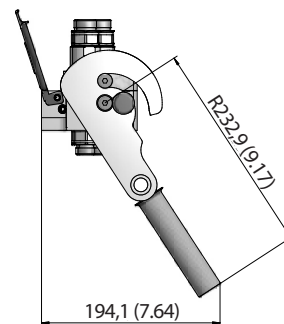
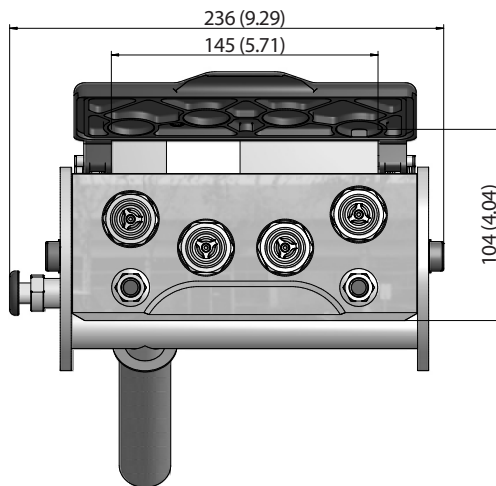

SW: Width across flats. All dimensions in mm (inch).

Series MK-R-10/4 • BG 2 • Nominal Size 10

Port A	Abmessung (mm/in)	Fixed half		Weight (^{kg} /lbs) ca. per 100	Mobile half		Weight (^{kg} /lbs) ca. per 100	Multicoupling System	
		Old Part Numbers	STAUFF Ordering Codes		Old Part Numbers	STAUFF Ordering Codes		Old Part Numbers	STAUFF Ordering Codes
Female Thread according to DIN 3852-2-A - ANSI B 1.20.3									
	G3/8"		MK74-1-IGF06	682	MK74-2-IGF06	334	MK74-8-IGF06	1016	
			QRC-MK-R-10/4-FP-G06-BT-W3	1503.55	QRC-MK-R-10/4-MP-G06-BP-W3	736.34	QRC-MK-R-10/4-CC-G06-S1-W3	2239.90	
	G 1/2"		MK74-1-IGF08	680	MK74-2-IGF08	332	MK74-8-IGF08	1012	
			QRC-MK-R-10/4-FP-G08-BT-W3	1499.14	QRC-MK-R-10/4-MP-G08-BP-W3	731.93	QRC-MK-R-10/4-CC-G08-S1-W3	2231.08	
	NPTF 1/2" - 14		MK74-1-INF08	678	MK74-2-INF08	330	MK74-8-INF08	1008	
			QRC-MK-R-10/4-FP-NF08-BT-W3	1494.73	QRC-MK-R-10/4-MP-NF08-BP-W3	727.53	QRC-MK-R-10/4-CC-NF08-S1-W3	2222.26	
Male Thread with 24° Conical Bore - Shape W according to DIN 3861									
	M16x1,5	10L	MK74-1-L1016	669	MK74-2-L1016	321	MK74-8-L1016	990	
			QRC-MK-R-10/4-FP-10L-BT-W3	1474.89	QRC-MK-R-10/4-MP-10L-BP-W3	707.68	QRC-MK-R-10/4-CC-10L-S1-W3	2182.58	
	M18x1,5	12L	MK74-1-L1218	669	MK74-2-L1218	321	MK74-8-L1218	990	
			QRC-MK-R-10/4-FP-12L-BT-W3	1474.89	QRC-MK-R-10/4-MP-12L-BP-W3	707.68	QRC-MK-R-10/4-CC-12L-S1-W3	2182.58	
	M22x1,5	15L	MK74-1-L1522	672	MK74-2-L1522	324	MK74-8-L1522	996	
			QRC-MK-R-10/4-FP-15L-BT-W3	1481.51	QRC-MK-R-10/4-MP-15L-BP-W3	714.30	QRC-MK-R-10/4-CC-15L-S1-W3	2195.80	
	M26x1,5	18L	MK74-1-L1826	674	MK74-2-L1826	326	MK74-8-L1826	1000	
			QRC-MK-R-10/4-FP-18L-BT-W3	1485.92	QRC-MK-R-10/4-MP-18L-BP-W3	718.71	QRC-MK-R-10/4-CC-18L-S1-W3	2204.62	

Note: The connection of the two halves of a coupling is achieved depending on the type. It is important to observe the positive engagement of plug-type couplings and the secure tightening of screw-type couplings to the limit stop of the thread. Forced or improper separation will result in malfunction of the coupling.



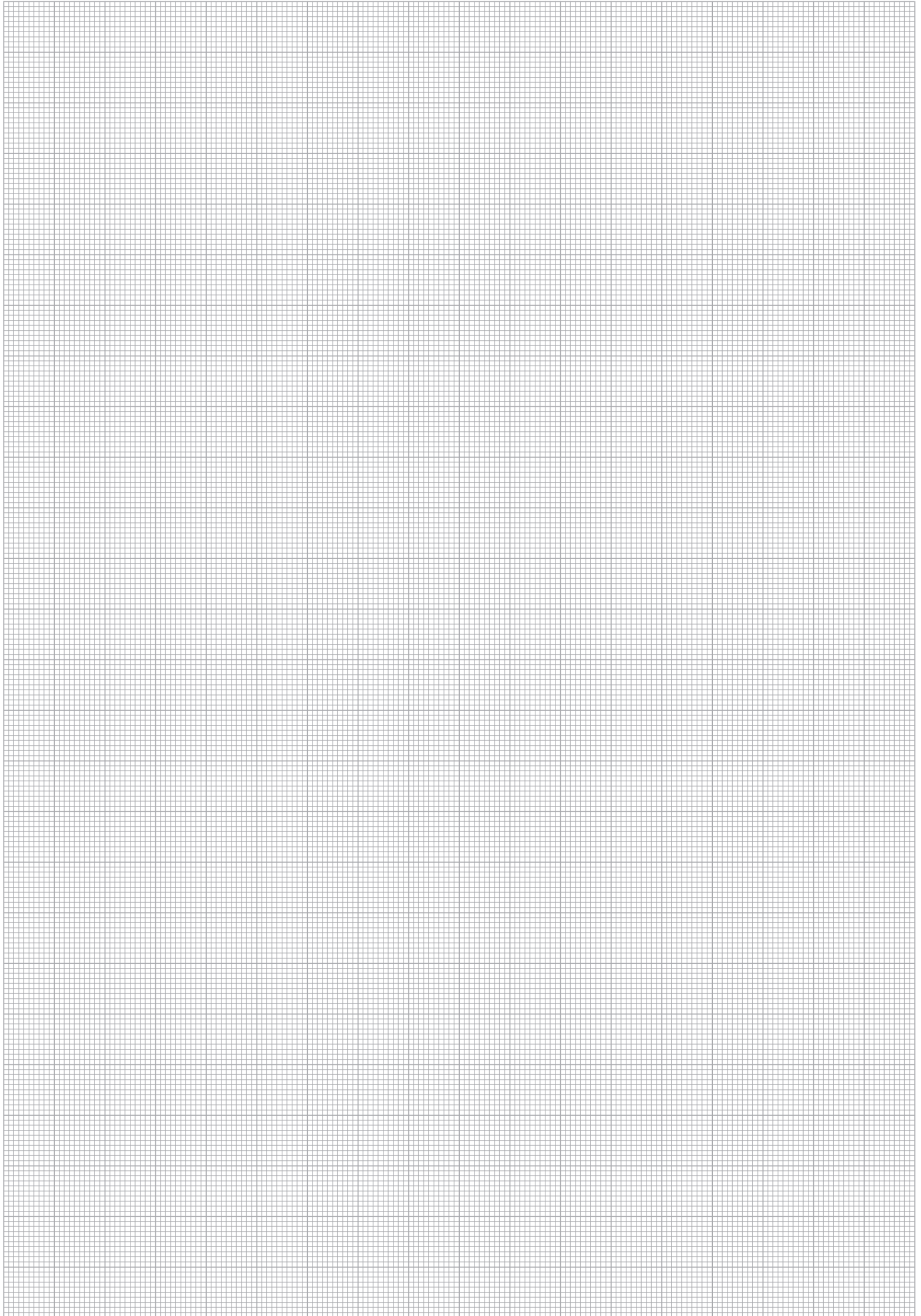

MK





Series HS - Carbon Steel

Series HS - Overview	114	Series HS-38 - BG 12 - Nominal Size 38	122
Series HS-06 - BG 1 - Nominal Size 6,3	115	Series HS - Special Designs	123
Series HS-10 - BG 2 - Nominal Size 10	116	Series HS - Dust Protection	124
Series HS-12 - BG 3 - Nominal Size 12,5	117-118		
Series HS-19 - BG 6 - Nominal Size 19	119		
Series HS-25 - BG 8 - Nominal Size 25	120		



HS



Series HS ▪ Carbon Steel

Material	Carbon Steel
Surface Finishing	Zinc-Plating and Thick-Film-Passivation (Chrome III)
Standard Seal Material(s)	NBR (Buna-N®) ²
Working Temperature	-25° C ... +100° C / -13° F ... +212° F
Valve Design	Poppet Valve
Connection	Screw
Disconnection	Screw
Connect Under Pressure	Male Tip/Female Body up to 33% of the Working Pressure with Tools
Application	Construction Machinery
ISO Interchange	ISO 14541 (BG 1-6)



²Alternative seal materials are available on request.

Technical Data

Series	BG	DN Zoll	DN metric ISO 4397	Q _{max}		Working Pressure		Bursting Pressure Connected		Female Body		Male Tip		Spillage	
				l/min	US GPM	bar	PSI	bar	PSI	bar	PSI	bar	PSI	ml	fl oz
HS-06	1	1/4"	6,3	20	5.28	450	6527	1800	26107	1400	20305	1400	20305	0,8	.0271
HS-10	2	3/8"	10	40	10.57	450	6527	1600	23206	1750	25382	1550	22481	1,3	.0440
HS-12	3	1/2"	12,5	80	21.13	400	5801	1400	20305	1200	17404	1200	17404	3,1	.1048
HS-19	6	3/4"	19	120	31.70	400	5801	1500	21756	1600	23206	1200	17404	5,6	.1894
HS-25	8	1"	25	160	42.27	300	4351	1180	17114	1500	21756	1100	15954	12,3	.4159
HS-38	12	1 1/2"	38	220	58.12	350	5076	1800	26107	1600	23206	1200	17404	52,3	1.7685

The indicated pressure ratings only apply to the coupling itself and depend on the connection type.

Flow Characteristics

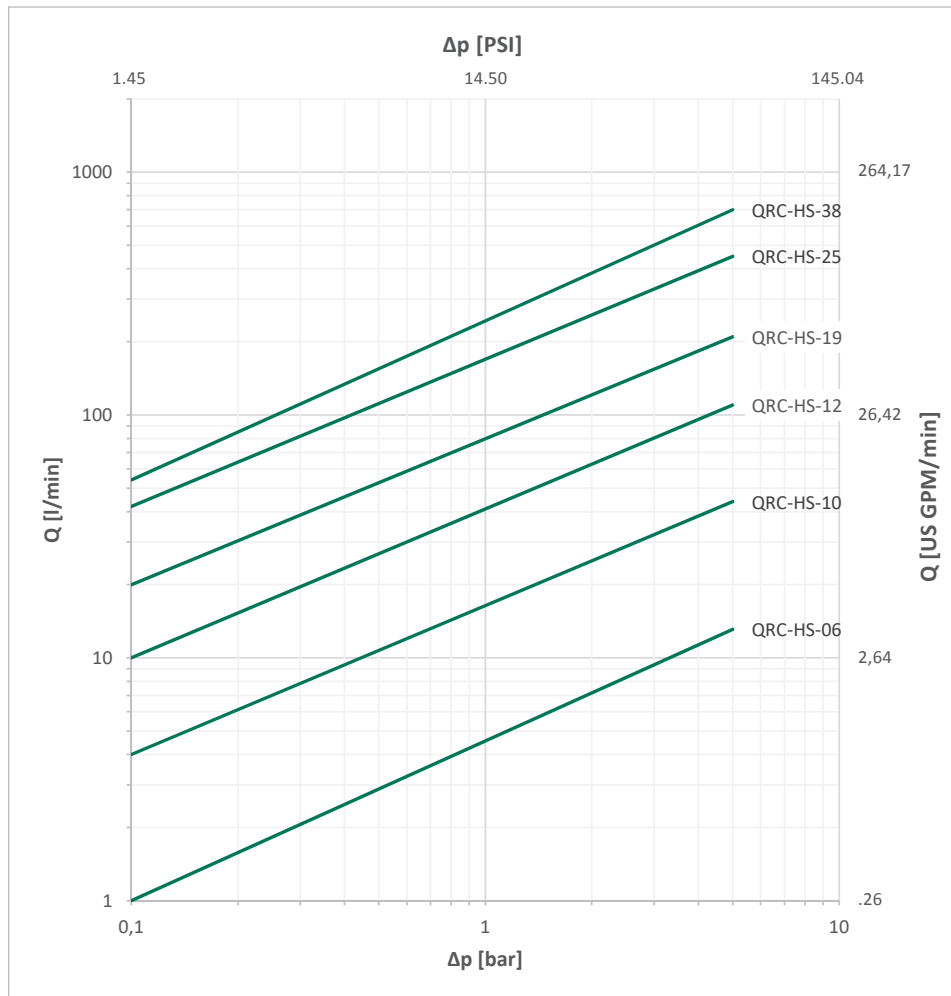

Please note: Unless otherwise stated, all flow characteristics have been determined with hydraulic oil with a kinematic viscosity of 28,8 - 35,2 mm²/s (28,8 - 35,2 cSt) and are only valid for components with non-reducing connections.



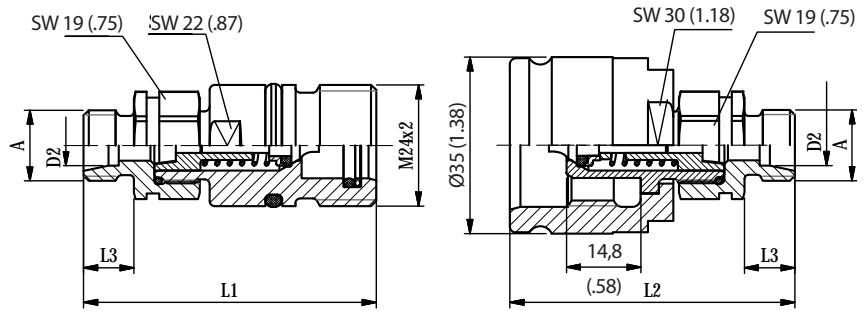

SW: Width across flats. All dimensions in mm (inch).

Series HS-06 • BG 1 • Nominal Size 6,3

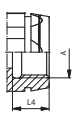
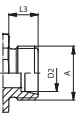
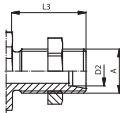
Port A	Dimensions (^{mm} / _{in})					Female Body	Weight	Male Tip	Weight
	ØD2	L1	L2	L3	L4	Old Part Numbers STAUFF Ordering Codes	(^{kg} / _{lbs}) ca. per 100	Old Part Numbers STAUFF Ordering Codes	(^{kg} / _{lbs}) ca. per 100
Female Thread according to DIN 3852-2-A - ANSI B 1.20.3									
	G 1/4"	60 2.36	59 2.32		13 .51	HS04-1-IGF04 QRC-HS-06-F-G04-BT-W66	12 26.46	HS04-2-IGF04 QRC-HS-06-M-G04-BT-W66	18,20 40.12
	NPTF 1/4" -18	60 2.36	59 2.32				HS04-1-INF04 QRC-HS-06-F-NF04-BT-W66	12 26.46	HS04-2-INF04 QRC-HS-06-M-NF04-B-W66
Male Thread with 24° Conical Bore - Shape W according to DIN 3861									
	M14x1,5	8L	58 2.28	57 2.24	10 .39	HS04-1-L0814 QRC-HS-06-F-08L-BT-W66	12,10 26.68	HS04-2-L0814 QRC-HS-06-M-08L-B-W66	18,70 41.23
Male Thread with 24° Conical Bore - Bulkhead - Shape W according to DIN 3861									
	M14x1,5	8L	73 2.87	72 2.83	25 .98	HS04-1-N0814 QRC-HS-06-F-08LB-BT-W66	13,70 30.20	HS04-2-N0814 QRC-HS-06-M-08LB-B-W66	20,30 44.75

HS

Note: The connection of the two halves of a coupling is achieved depending on the type. It is important to observe the positive engagement of plug-type couplings and the secure tightening of screw-type couplings to the limit stop of the thread. Forced or improper separation will result in malfunction of the coupling.



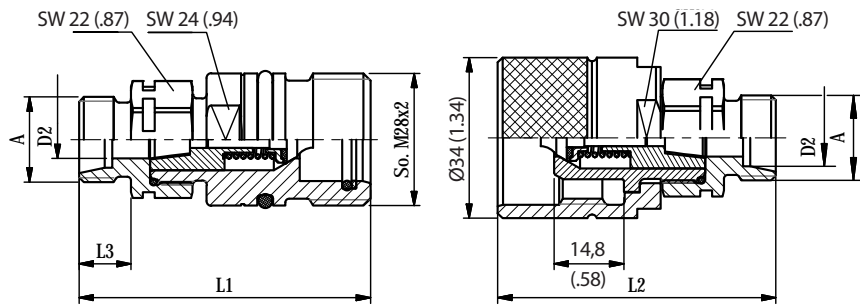

SW: Width across flats. All dimensions in mm (inch).

Series HS-10 • BG 2 • Nominal Size 10

Port A	Dimensions (mm/in)				Female Body	Weight	Male Tip	Weight	
	ØD2	L1	L2	L3	Old Part Numbers STAUFF Ordering Codes	(kg/lbs) ca. per 100	Old Part Numbers STAUFF Ordering Codes	(kg/lbs) ca. per 100	
Male Thread according to DIN ISO 8434-1									
	G 3/8"	65	62	12	HS08-1-AGF06	16,90	HS08-2-AGF06	18,10	
		2.56	2.44	.47	QRC-HS-10-F-B06-BT-W66	37.26	QRC-HS-10-M-B06-B-W66	39.90	
	UNF 3/4" -16	67	53	17	HS08-1-AUF08	16	HS08-2-AUF08	17,50	
		2.65	2.07	.65	QRC-HS-10-F-J12-BT-W66	35.27	QRC-HS-10-M-J08-B-W66	38.58	
Female Thread according to DIN 3852-2-A - ISO 9974-1 - ANSI B 1.20.3									
	G1/4"	64	61		HS08-1-IGF04	18	HS08-2-IGF04	19,20	
		2.52	2.40		QRC-HS-10-F-G04-BT-W66	39.68	QRC-HS-10-M-G04-B-W66	42.33	
	G3/8"	64	61		HS08-1-IGF06	17,20	HS08-2-IGF06	18,40	
		2.52	2.40		QRC-HS-10-F-G06-BT-W66	37.92	QRC-HS-10-M-G06-B-W66	40.57	
	M16x1,5	64	61		HS08-1-IMF16	16,10	HS08-2-IMF16	17,40	
		2.52	2.40		QRC-HS-10-F-M16-BT-W66	35.49	QRC-HS-10-M-M16-B-W66	38.36	
	NPTF 3/8" -18	64	61		HS08-1-INF06	17,30	HS08-2-INF06	18,50	
		2.52	2.40		QRC-HS-10-F-NF06-BT-W66	38.14	QRC-HS-10-M-NF06-B-W66	40.79	
Male Thread with 24° Conical Bore - Shape W according to DIN 3861									
	M14x1,5	8L	61	58	10	HS08-1-L0814	14,40	HS08-2-L0814	15,80
			2.39	2.28	.39	QRC-HS-10-F-08L-BT-W66	31.75	QRC-HS-10-M-08L-B-W66	34.83
	M16x1,5	10L	62	59	11	HS08-1-L1016	15,80	HS08-2-L1016	16,90
			2.43	2.32	.43	QRC-HS-10-F-10L-BT-W66	34.83	QRC-HS-10-M-10L-B-W66	37.26
	M18x1,5	12L	62	59	11	HS08-1-L1218	16	HS08-2-L1218	17,20
			2.43	2.32	.43	QRC-HS-10-F-12L-BT-W66	35.27	QRC-HS-10-M-12L-B-W66	37.92
	M16x1,5	8S	63	60	12	HS08-1-S0816	16,30	HS08-2-S0816	17,40
			2.47	2.36	.47	QRC-HS-10-F-08S-BT-W66	35.94	QRC-HS-10-M-08S-B-W66	38.36
	M18x1,5	10S	63	60	12	HS08-1-S1018	16,40	HS08-2-S1018	17,60
			2.47	2.36	.47	QRC-HS-10-F-10S-BT-W66	36.16	QRC-HS-10-M-10S-B-W66	38.80
	M20x1,5	12S	63	60	12	HS08-1-S1220	15,40	HS08-2-S1220	17,90
			2.47	2.36	.47	QRC-HS-10-F-12S-BT-W66	33.95	QRC-HS-10-M-12S-B-W66	39.46
Male Thread with 24° Conical Bore - Bulkhead - Shape W according to DIN 3861									
	M14x1,5	8L	76	73	25	HS08-1-N0814	17,20	HS08-2-N0814	17,60
			2.98	2.87	.98	QRC-HS-10-F-08LB-BT-W66	37.92	QRC-HS-10-M-08LB-B-W66	38.80
	M16x1,5	10L	77	74	26	HS08-1-N1016	18,70	HS08-2-N1016	17
			3.02	2.91	1.02	QRC-HS-10-F-10LB-BT-W66	41.23	QRC-HS-10-M-10LB-B-W66	37.48
	M22x1,5	15L	78	75	27	HS08-1-N1522	23,10	HS08-2-N1522	17,50
			3.06	2.95	1.06	QRC-HS-10-F-15LB-BT-W66	50.93	QRC-HS-10-M-15LB-BT-W66	38.58
	M16x1,5	08S	78	5	27	HS08-1-T0816	16	HS08-2-T0816	17
			3.06	.20	1.06	QRC-HS-10-F-08SB-BT-W66	35.27	QRC-HS-10-M-08SB-BT-W66	37.48
	M18x1,5	10S	78	75	27	HS08-1-T1018	17,50	HS08-2-T1018	17,50
			3.06	2.95	1.06	QRC-HS-10-F-10SB-BT-W66	38.58	QRC-HS-10-M-10SB-B-W66	38.58
	M20x1,5	12S	78	75	27	HS08-1-T1220	31	HS08-2-T1220	17,10
			3.06	2.95	1.06	QRC-HS-10-F-12SB-BT-W66	68.34	QRC-HS-10-M-12SB-B-W66	37.70

Note: The connection of the two halves of a coupling is achieved depending on the type. It is important to observe the positive engagement of plug-type couplings and the secure tightening of screw-type couplings to the limit stop of the thread. Forced or improper separation will result in malfunction of the coupling.



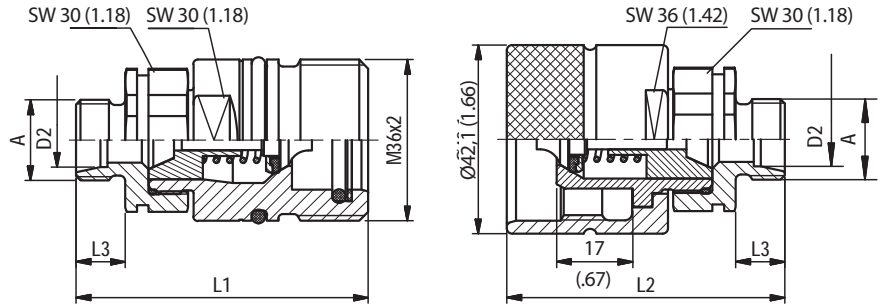

SW: Width across flats. All dimensions in mm (inch).

Series HS-12 ▪ BG 3 ▪ Nominal Size 12,5

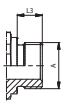
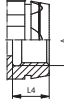
Port A	Dimensions (^{mm} / _{in})				Female Body	Weight	Male Tip	Weight	
	ØD2	L1	L2	L3	L4	Old Part Numbers STAUFF Ordering Codes	(^{kg} / _{lbs}) ca. per 100	Old Part Numbers STAUFF Ordering Codes	(^{kg} / _{lbs}) ca. per 100
Male Thread according to DIN 3852-2 - ISO 9974-3									
	G 3/8"	69	66	12		HS10-1-AGF06 QRC-HS-12-F-B06-BT-W66	28,70 63.27	HS10-2-AGF06 QRC-HS-12-M-B06-B-W66	26,70 58.86
	G 1/2"	69	66	12		HS10-1-AGF08 QRC-HS-12-F-B08-BT-W66	29,50 65.04	HS10-2-AGF08 QRC-HS-12-M-B08-B-W66	27,10 59.75
	M22x1,5	69	66	12		HS10-1-AMF22 QRC-HS-12-F-M22M-BT-W66	29,60 65.26	HS10-2-AMF22 QRC-HS-12-M-M22M-B-W66	26,20 57.76
Female Thread according to DIN 3852-2-A - ISO 6149-1 - ANSI B 1.20.3 - SAE J1926-1									
	G3/8"	67	64		15	HS10-1-IGF06 QRC-HS-12-F-G06-BT-W66	30,80 67.90	HS10-2-IGF06 QRC-HS-12-M-G06-B-W66	28,80 63.49
		2.64	2.52		.59				
	G1/2"	67	64		15	HS10-1-IGF08 QRC-HS-12-F-G08-BT-W66	31,90 70.33	HS10-2-IGF08 QRC-HS-12-M-G08-B-W66	29,90 65.92
		2.64	2.52		.59				
	M18x1,5	67	64		15	HS10-1-IMF18 QRC-HS-12-F-M180R-BT-W66	30,20 66.58	HS10-2-IMF18 QRC-HS-12-M-M180R-B-W66	28,20 62.17
	M22x1,5	67	64		15	HS10-1-IMF22 QRC-HS-12-F-M220R-BT-W66	29,20 64.37	HS10-2-IMF22 QRC-HS-12-M-M220R-B-W66	26,60 58.64
		2.64	2.52		.59				
NPTF 1/2" -14	70	67			HS10-1-INF08 QRC-HS-12-F-NF08-BT-W66	29,60 65.26	HS10-2-INF08 QRC-HS-12-M-NF08-B-W66	27,40 60.41	
UNF 7/8" -14	2.76	2.64							
	73	70		18	HS10-1-IUF10 QRC-HS-12-F-U10-BT-W66	29,20 64.37	HS10-2-IUF10 QRC-HS-12-M-U10-B-W66	27 59.52	
	2.87	2.76		.71					

Note: The connection of the two halves of a coupling is achieved depending on the type. It is important to observe the positive engagement of plug-type couplings and the secure tightening of screw-type couplings to the limit stop of the thread. Forced or improper separation will result in malfunction of the coupling.



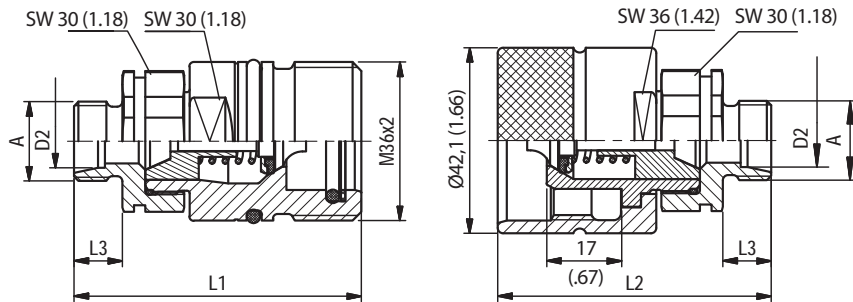

SW: Width across flats. All dimensions in mm (inch).

Series HS-12 • BG 3 • Nominal Size 12,5

Port A	Dimensions (mm/in)				Female Body	Weight	Male Tip	Weight		
	ØD2	L1	L2	L3	Old Part Numbers STAUFF Ordering Codes	(^{kg} / _{lbs}) ca. per 100	Old Part Numbers STAUFF Ordering Codes	(^{kg} / _{lbs}) ca. per 100		
Male Thread with 24° Conical Bore - Shape W according to DIN 3861										
	M14x1,5	8L	64 2.53	61 2.40	10 .39	HS10-1-L0814 QRC-HS-12-F-08L-BT-W66	26,40 58.20	HS10-2-L0814 QRC-HS-12-M-08L-B-W66	25,40 56.00	
	M16x1,5	10L	65 2.57	62 2.44	11 .43	HS10-1-L1016 QRC-HS-12-F-10L-BT-W66	27,70 61.07	HS10-2-L1016 QRC-HS-12-M-10L-B-W66	25,70 56.66	
			65 2.57	62 2.44	11 .43	HS10-1-L1218 QRC-HS-12-F-12L-BT-W66	27,80 61.29	HS10-2-L1218 QRC-HS-12-M-12L-B-W66	25,80 56.88	
	M22x1,5	15L	66 2.61	63 2.48	12 .47	HS10-1-L1522 QRC-HS-12-F-15L-BT-W66	28,40 62.61	HS10-2-L1522 QRC-HS-12-M-15L-B-W66	26,40 58.20	
			66 2.61	63 2.48	12 .47	HS10-1-L1826 QRC-HS-12-F-18L-BT-W66	28,40 62.61	HS10-2-L1826 QRC-HS-12-M-18L-B-W66	26,40 58.20	
	M18x1,5	10S	66 2.61	63 2.48	12 .47	HS10-1-S1018 QRC-HS-12-F-10S-BT-W66	28,40 62.61	HS10-2-S1018 QRC-HS-12-M-10S-B-W66	26,40 58.20	
			66 2.61	63 2.48	12 .47	HS10-1-S1220 QRC-HS-12-F-12S-BT-W66	28,40 62.61	HS10-2-S1220 QRC-HS-12-M-12S-B-W66	26,40 58.20	
	M22x1,5	14S	68 2.69	65 2.56	14 .55	HS10-1-S1422 QRC-HS-12-F-14S-BT-W66	29,20 64.37	HS10-2-S1422 QRC-HS-12-M-10S-B-W66	27,20 59.97	
			68 2.69	65 2.56	14 .55	HS10-1-S1624 QRC-HS-12-F-16S-BT-W66	29,20 64.37	HS10-2-S1624 QRC-HS-12-M-16S-B-W66	27,20 59.97	
	M30x2	20S	70 2.76	67 2.64	16 .63	HS10-1-S2030 QRC-HS-12-F-20S-BT-W66	28,40 62.61	HS10-2-S2030* QRC-HS-12-M-20S-B-W66	25,70 56.66	
	Male Thread with 24° Conical Bore - Bulkhead - Shape W according to DIN 3861									
		M14x1,5	08L	80 3.16	77 3.03	26 1.02	HS10-1-N0814 QRC-HS-12-F-08LB-BT-W66	28,60 63.05	HS10-2-N0814 QRC-HS-12-M-08LB-B-W66	26,20 57.76
				M16x1,5	10L	80 3.16	77 3.03	26 1.02	HS10-1-N1016 QRC-HS-12-F-10LB-BT-W66	30,70 67.68
		M18x1,5	12L			84 3.31	81 3.19	30 1.18	HS10-1-N1218 QRC-HS-12-F-12LB-BT-W66	30,60 67.46
M22x1,5				15L	81 3.20	78 3.07	27 1.06	HS10-1-N1522 QRC-HS-12-F-15LB-BT-W66	31,40 69.23	HS10-2-N1522 QRC-HS-12-M-15LB-B-W66
		M26x1,5	18L		81 3.20	78 3.07	27 1.06	HS10-1-N1826 QRC-HS-12-F-18LB-BT-W66	36,60 80.69	HS10-2-N1826 QRC-HS-12-M-18LB-B-W66
M18x1,5				10S	80 3.16	77 3.03	26 1.02	HS10-1-T1018 QRC-HS-12-F-10SB-BT-W66	30,70 67.68	HS10-2-T1018 QRC-HS-12-M-10SB-B-W66
		M20x1,5	12S		81 3.20	78 3.07	27 1.06	HS10-1-T1220 QRC-HS-12-F-12SB-BT-W66	31,20 68.78	HS10-2-T1220 QRC-HS-12-M-12SB-B-W66
M22x1,5				14S	83 3.28	80 3.15	29 1.14	HS10-1-T1422 QRC-HS-12-F-14SB-BT-W66	32,80 72.31	HS10-2-T1422 QRC-HS-12-M-14SB-B-W66
		M24x1,5	16S		83 3.28	80 3.15	29 1.14	HS10-1-T1624 QRC-HS-12-F-16SB-BT-W66	34,20 75.40	HS10-2-T1624 QRC-HS-12-M-16SB-B-W66

Note: The connection of the two halves of a coupling is achieved depending on the type. It is important to observe the positive engagement of plug-type couplings and the secure tightening of screw-type couplings to the limit stop of the thread. Forced or improper separation will result in malfunction of the coupling.



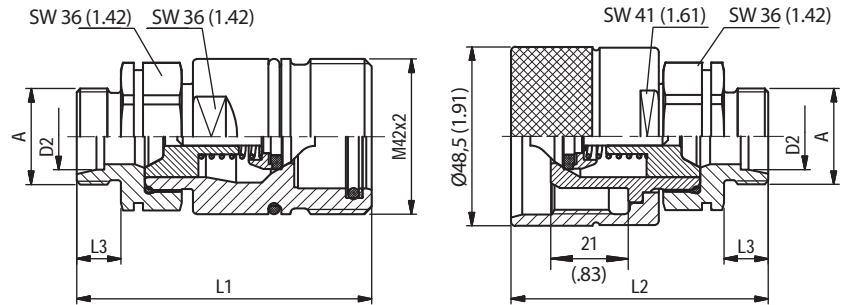

SW: Width across flats. All dimensions in mm (inch).

Series HS-19 • BG 6 • Nominal Size 19

Port A	Dimensions (mm/in)				Female Body		Weight (^{kg} /lbs) ca. per 100	Male Tip		Weight (^{kg} /lbs) ca. per 100
	ØD2	L1	L2	L3	L4	Old Part Numbers STAUFF Ordering Codes		Old Part Numbers STAUFF Ordering Codes		
Female Thread according to DIN 3852-2-A - ISO 9974-1 - ANSI B 1.20.3										
	G1/2"	86	75		19	HS12-1-IGF08	52,60	HS12-2-IGF08	50,40	
		3.39	2.95		.75	QRC-HS-19-F-G08-BT-W66	115.96	QRC-HS-19-M-G08-B-W66	111.11	
	G3/4"	86	75		19	HS12-1-IGF12	63,60	HS12-2-IGF12	47,60	
		3.39	2.95		.75	QRC-HS-19-F-G12-BT-W66	140.21	QRC-HS-19-M-G12-B-W66	104.94	
	M22x1,5	86	75		19	HS12-1-IMF22	55	HS12-2-IMF22	49	
	3.39	2.95		.75	QRC-HS-19-F-M22-BT-W66	121.25	QRC-HS-19-M-M22-B-W66	108.03		
NPTF 3/4" -14	86	75			HS12-1-INF12	55	HS12-2-INF12	47,60		
	3.39	2.95			QRC-HS-19-F-NF12-BT-W66	121.25	QRC-HS-19-M-NF12-B-W66	104.94		
Male Thread with 24° Conical Bore - Shape W according to DIN 3861										
	M18x1,5	12L	79	69	11	HS12-1-L1218	46	HS12-2-L1218	40,80	
			3.11	2.72	.43		QRC-HS-19-F-12L-BT-W66	101.41	QRC-HS-19-M-12L-B-W66	89.95
	M22x1,5	15L	80	70	12	HS12-1-L1522	46,60	HS12-2-L1522	41,30	
			3.15	2.76	.47		QRC-HS-19-F-15L-BT-W66	102.74	QRC-HS-19-M-15L-B-W66	91.05
	M26x1,5	18L	80	70	12	HS12-1-L1826	47,90	HS12-2-L1826	41,90	
			3.15	2.76	.47		QRC-HS-19-F-18L-BT-W66	105.60	QRC-HS-19-M-18L-B-W66	92.37
	M30x2	22L	82	72	14	HS12-1-L2230	49,20	HS12-2-L2230	43,10	
			3.23	2.83	.55		QRC-HS-19-F-22L-BT-W66	108.47	QRC-HS-19-M-22L-B-W66	95.02
	M24x1,5	16S	82	72	14	HS12-1-S1624	47,40	HS12-2-S1624	40,20	
			3.23	2.83	.55		QRC-HS-19-F-16S-BT-W66	104.50	QRC-HS-19-M-16S-B-W66	88.63
	M30x2	20S	84	74	16	HS12-1-S2030	50	HS12-2-S2030	44	
			3.31	2.91	.63		QRC-HS-19-F-20S-BT-W66	110.23	QRC-HS-19-M-20S-B-W66	97
Male Thread with 24° Conical Bore - Bulkhead - Shape W according to DIN 3861										
	M18x1,5	12L	94	84	26	HS12-1-N1218	48,80	HS12-2-N1218	42,20	
			3.70	3.31	1.02		QRC-HS-19-F-12LB-BT-W66	107.59	QRC-HS-19-M-12LB-B-W66	93.04
	M22x1,5	15L	95	85	27	HS12-1-N1522	51	HS12-2-N1522	43,80	
			3.74	3.35	1.06		QRC-HS-19-F-15LB-BT-W66	112.44	QRC-HS-19-M-15LB-B-W66	96.56
	M26x1,5	18L	95	85	27	HS12-1-N1826	55,70	HS12-2-N1826	47,50	
			3.74	3.35	1.06		QRC-HS-19-F-18LB-BT-W66	122.80	QRC-HS-19-M-18LB-B-W66	104.72
	M30x2	22L	104	94	36	HS12-1-N2230	59,40	HS12-2-N2230	52,40	
			4.09	3.70	1.42		QRC-HS-19-F-22LB-BT-W66	130.95	QRC-HS-19-M-22LB-B-W66	115.52
	M24x1,5	16S	97	87	29	HS12-1-T1624	53,40	HS12-2-T1624	46,20	
			3.82	3.43	1.14		QRC-HS-19-F-16SB-BT-W66	117.73	QRC-HS-19-M-16SB-B-W66	101.85
	M30x2	20S	104	94	36	HS12-1-T2030	62,40	HS12-2-T2030	56,50	
			4.09	3.70	1.42		QRC-HS-19-F-20SB-BT-W66	137.57	QRC-HS-19-M-20SB-B-W66	124.56

HS

Note: The connection of the two halves of a coupling is achieved depending on the type. It is important to observe the positive engagement of plug-type couplings and the secure tightening of screw-type couplings to the limit stop of the thread. Forced or improper separation will result in malfunction of the coupling.



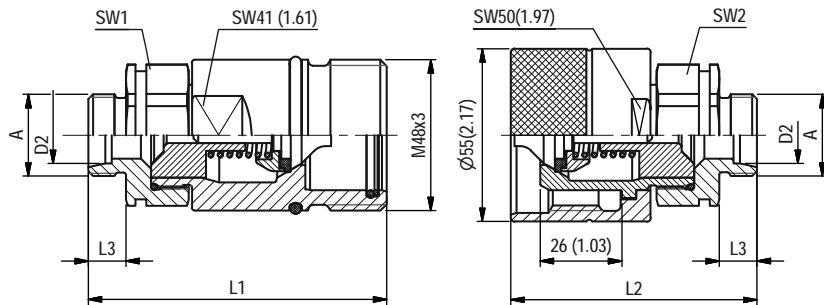

SW: Width across flats. All dimensions in mm (inch).

Series HS-25 • BG 8 • Nominal Size 25

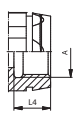
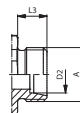
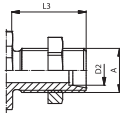
Port A	Dimensions (mm/in)						Female Body		Weight (*9/16) ca. per 100	Male Tip		Weight (*9/16) ca. per 100
	ØD2	L1	L2	L3	L4	SW1	SW2	Old Part Numbers		STAUFF Ordering Codes	Old Part Numbers	
Female Thread according to DIN 3852-2-A - ANSI B 1.20.3												
	G3/4"	98	81		19	41	41	HS20-1-IGF12	78,10	HS20-2-IGF12	68,80	
	G1"	3.86	3.19		.75	1.61	1.61	QRC-HS-25-F-G12-BT-W66	172.18	QRC-HS-25-M-G12-B-W66	151.68	
		3.86	3.19		.75	1.61	1.61	QRC-HS-25-F-G16-BT-W66	162.70	QRC-HS-25-M-G16-B-W66	142.20	
	NPTF 1" -11 1/2	98	81			41	41	HS20-1-INF16	78	HS20-2-INF16	60,10	
	3.86	3.19			1.61	1.61	QRC-HS-25-F-NF16-BT-W66	171.96	QRC-HS-25-M-NF16-B-W66	132.50		
Male Thread with 24° Conical Bore - Shape W according to DIN 3861												
	M26x1,5	18L	95	78	12		41	41	HS20-1-L1826	70,90	HS20-2-L1826	61,60
		3.74	3.07	.47		1.61	1.61	QRC-HS-25-F-18L-BT-W66	156.31	QRC-HS-25-M-18L-B-W66	135.80	
	M30x2	22L	97	80	14		41	41	HS20-1-L2230	71,50	HS20-2-L2230	62,20
			3.82	3.15	.55		1.61	1.61	QRC-HS-25-F-22L-BT-W66	157.63	QRC-HS-25-M-22L-B-W66	137.13
	M36x2	28L	97	80	14		41	41	HS20-1-L2836	72	HS20-2-L2836	67,20
			3.82	3.15	.55		1.61	1.61	QRC-HS-25-F-28L-BT-W66	158.73	QRC-HS-25-M-28L-B-W66	148.15
	M45x2	35L	99	82	16		46	46	HS20-1-L3545	80,50	HS20-2-L3545	71,30
			3.90	3.23	.63		1.81	1.81	QRC-HS-25-F-35L-BT-W66	177.47	QRC-HS-25-M-35L-B-W66	157.19
	M30x2	20S	99	82	16		41	41	HS20-1-S2030	73,10	HS20-2-S2030	63,90
			3.90	3.23	.63		1.61	1.61	QRC-HS-25-F-20S-BT-W66	161.16	QRC-HS-25-M-20S-B-W66	140.88
M36x2	25S	101	84	18		41	41	HS20-1-S2536	75,30	HS20-2-S2536	66	
		3.98	3.31	.71		1.61	1.61	QRC-HS-25-F-25S-BT-W66	166.01	QRC-HS-25-M-25S-B-W66	145.51	
M42x2	30S	103	86	20		41	41	HS20-1-S3042	87,10	HS20-2-S3042	65	
		4.06	3.39	.79		1.61	1.61	QRC-HS-25-F-30S-BT-W66	192.02	QRC-HS-25-M-30S-B-W66	143.30	
M52x2	38S	105	88	22		55	55	HS20-1-S3852	108	HS20-2-S3852	90,10	
		4.13	3.46	.87		2.17	2.17	QRC-HS-25-F-38S-BT-W66	238.10	QRC-HS-25-M-38S-B-W66	198.64	
Male Thread with 24° Conical Bore - Bulkhead - Shape W according to DIN 3861												
	M22x1,5	15L	110	93	27		41	41	HS20-1-N1522	82	HS20-2-N1522	62
			4.33	3.66	1.06		1.61	1.61	QRC-HS-25-F-15LB-BT-W66	180.78	QRC-HS-25-M-15LB-B-W66	136.69
	M26x1,5	18L	115	98	32		41	41	HS20-1-N1826	76,60	HS20-2-N1826	63,80
			4.53	3.86	1.26		1.61	1.61	QRC-HS-25-F-18LB-BT-W66	168.87	QRC-HS-25-M-18LB-B-W66	140.65
	M30x2	22L	117	100	34		41	41	HS20-1-N2230	86,10	HS20-2-N2230	65
			4.61	3.94	1.34		1.61	1.61	QRC-HS-25-F-22LB-BT-W66	189.82	QRC-HS-25-M-22LB-B-W66	143.30
	M36x2	28L	117	100	34		41	41	HS20-1-N2836	89,90	HS20-2-N2836	69
			4.61	3.94	1.34		1.61	1.61	QRC-HS-25-F-28LB-BT-W66	198.20	QRC-HS-25-M-28LB-B-W66	152.12
	M30x2	20S	121	104	38		41	41	HS20-1-T2030	94	HS20-2-T2030	70,60
			4.76	4.09	1.50		1.61	1.61	QRC-HS-25-F-20SB-BT-W66	207.23	QRC-HS-25-M-20SB-B-W66	155.65
	M36x2	25S	121	104	38		41	41	HS20-1-T2536	94,70	HS20-2-T2536	74
			4.76	4.09	1.50		1.61	1.61	QRC-HS-25-F-25SB-BT-W66	208.78	QRC-HS-25-M-25SB-B-W66	163.14
M42x2	30S	123	106	40		46	46	HS20-1-T3042	104	HS20-2-T3042	85	
		4.84	4.17	1.57		1.81	1.81	QRC-HS-25-F-30SB-BT-W66	229.28	QRC-HS-25-M-30SB-B-W66	187.39	
M52x2	38S	123	106	40		55	55	HS20-1-T3852	140,40	HS20-2-T3852	85	
		4.84	4.17	1.57		2.17	2.17	QRC-HS-25-F-38SB-BT-W66	309.53	QRC-HS-25-M-38SB-B-W66	187.39	

Note: The connection of the two halves of a coupling is achieved depending on the type. It is important to observe the positive engagement of plug-type couplings and the secure tightening of screw-type couplings to the limit stop of the thread. Forced or improper separation will result in malfunction of the coupling.



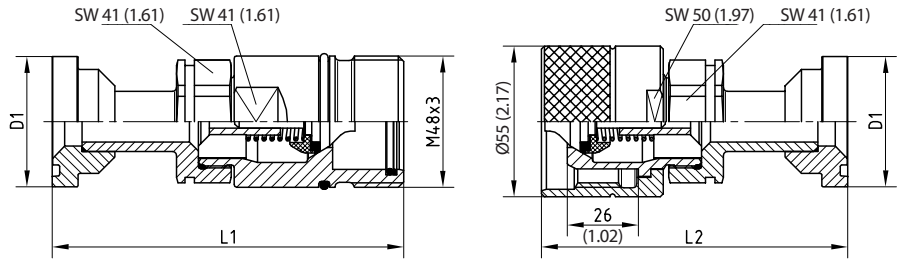

SW: Width across flats. All dimensions in mm (inch).

Series HS-25 ▪ BG 8 ▪ Nominal Size 25

Flange	Dimensions (^{mm} / _{in})						Female Body		Weight	Male Tip		Weight
	ØD1	L1	L2	L3	L4	L5	Old Part Numbers	(^{kg} / _{lbs}) ca.	Old Part Numbers	(^{kg} / _{lbs}) ca.		
							STAUFF Ordering Codes	per 100	STAUFF Ordering Codes	per 100		
3/4"	41,3	127	110				HS20-1-AFS12	85,20	HS20-2-AFS12	76		
		1.63	5.00				QRC-HS-25-F-FH612-BT-W66	187.83	QRC-HS-25-M-FH612-B-W66	167.55		
1"	47,6	129	112				HS20-1-AFS16	93,20	HS20-2-AFS16	83,90		
		1.87	5.08				QRC-HS-25-F-FH616-BT-W66	205.47	QRC-HS-25-M-FH616-B-W66	184.97		

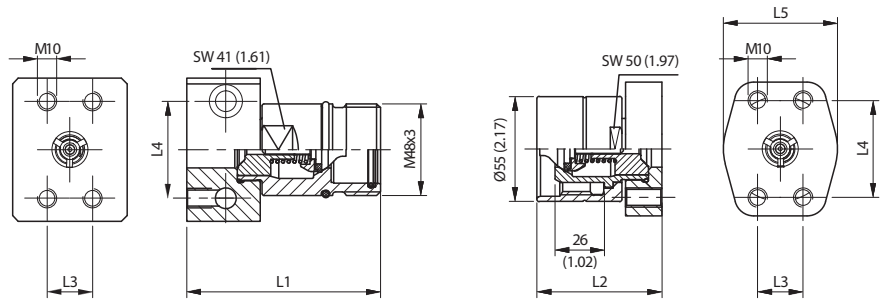

SW: Width across flats. All dimensions in mm (inch).

Flange	Dimensions (^{mm} / _{in})						Female Body		Weight	Male Tip		Weight
	ØD2	L1	L2	L3	L4	L5	Old Part Numbers	(^{kg} / _{lbs}) ca.	Old Part Numbers	(^{kg} / _{lbs}) ca.		
							STAUFF Ordering Codes	per 100	STAUFF Ordering Codes	per 100		
3/4"		102	65	23,8	50,8	60	HS20-1-X0010	163,10	HS20-2-X0011	87,70		
		4.02	2.56	.94	2.00	2.36	QRC-HS-25-F-C612M-B-W66-700514	359.57	QRC-HS-25-M-C612M-B-W66	193.35		

HS

Note: The connection of the two halves of a coupling is achieved depending on the type. It is important to observe the positive engagement of plug-type couplings and the secure tightening of screw-type couplings to the limit stop of the thread. Forced or improper separation will result in malfunction of the coupling.



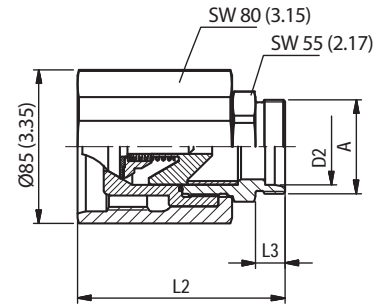
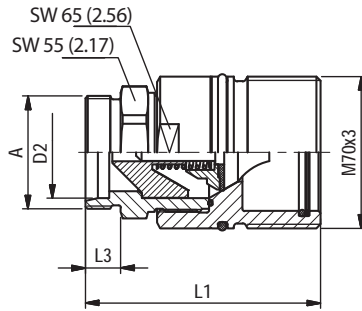

SW: Width across flats. All dimensions in mm (inch).

Series HS-38 • BG 12 • Nominal Size 38

Port A	Dimensions (mm/in)					Female Body	Weight	Male Tip	Weight	
	ØD2	L1	L2	L3	L4	Old Part Numbers STAUFF Ordering Codes	(kg/lbs) ca. per 100	Old Part Numbers STAUFF Ordering Codes	(kg/lbs) ca. per 100	
Female Thread according to DIN 3852-2-A / Innengewinde DIN 3852-2-A										
	G 1" 1/4	125	131		29	HS25-1-IGF20	190,70	HS25-2-IGF20	276,60	
		4.92	5.16		1.14	QRC-HS-38-F-G20-BT-W66	420.42	QRC-HS-38-M-G20-B-W66	609.80	
	G 1" 1/2	127	134		31	HS25-1-IGF24	184,90	HS25-2-IGF24	270,80	
5.00		5.28		1.22	QRC-HS-38-F-G24-BT-W66	407.63	QRC-HS-38-M-G24-B-W66	597.01		
Male Thread with 24° Conical Bore - Shape W according to DIN 3861										
	M45x2	35L	105	112	16		HS25-1-L3545	156	HS25-2-L3545	209
			4.11	4.39	.63		QRC-HS-38-F-35L-BT-W66	343.92	QRC-HS-38-M-35L-B-W66	460.77
	M52x2	42L	105	112	16		HS25-1-L4252	162	HS25-2-L4252	215
			4.11	4.39	.63		QRC-HS-38-F-42L-BT-W66	357.15	QRC-HS-38-M-42L-B-W66	473.99
	M42x2	30S	112	119	20		HS25-1-S3042	157,20	HS25-2-S3042	209,20
			4.41	4.69	.79		QRC-HS-38-F-30S-BT-W66	346.57	QRC-HS-38-M-30S-B-W66	461.21
M52x2	38S	112	118	22		HS25-1-S3852	162,40	HS25-2-S3852	215,30	
		4.41	4.65	.87		QRC-HS-38-F-38S-BT-W66	358.03	QRC-HS-38-M-38S-B-W66	474.66	
Male Thread with 24° Conical Bore - Bulkhead - Shape W according to DIN 3861										
	M45x2	35L	125	132	36		HS25-1-N3545	173	HS25-2-N3545	234
			4.90	5.18	1.42		QRC-HS-38-F-35LB-BT-W66	381.40	QRC-HS-38-M-35LB-B-W66	515.88
	M52x2	42L	129	132	36		HS25-1-N4252	172,50	HS25-2-N4252	233,50
			5.08	5.20	1.42		QRC-HS-38-F-42LB-BT-W66	380.30	QRC-HS-38-M-42LB-B-W66	514.78
	M42x2	30S	133	140	40		HS25-1-T3042	182,40	HS25-2-T3042	268,30
			5.24	5.51	1.57		QRC-HS-38-F-30SB-BT-W66	402.12	QRC-HS-38-M-30SB-B-W66	591.50
M52x2	38S	132	139	40		HS25-1-T3852	173	HS25-2-T3852	279,30	
		5.20	5.47	1.57		QRC-HS-38-F-38SB-BT-W66	381.40	QRC-HS-38-M-38SB-B-W66	615.75	

HS

Note: The connection of the two halves of a coupling is achieved depending on the type. It is important to observe the positive engagement of plug-type couplings and the secure tightening of screw-type couplings to the limit stop of the thread. Forced or improper separation will result in malfunction of the coupling.

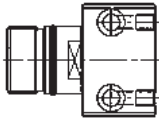
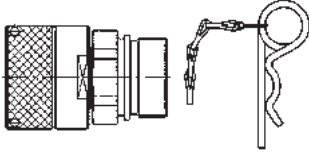
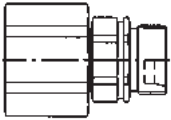

<p>1</p> 	<p>The mating flange shown on page 53 is also available for the screw-type carrier Type HS-12, size 1/2", 410 bar (6000 PSI).</p>
<p>2</p> 	<p>Screw-type probes of the types HS-25 and HS-38 are available with a safety clamp which prevents inadvertent release of the coupling connection even under strong hydraulic impulses or vibrations.</p> <p>Also possible for Series RK/RH on request.</p>
<p>3</p> 	<p>In special cases users may desire a screw-type sleeve which offers better accessibility for a spanner. For this purpose, a sleeve made from 55 mm (2.17 in) hexagonal material is available.</p>

HS

Note: The connection of the two halves of a coupling is achieved depending on the type. It is important to observe the positive engagement of plug-type couplings and the secure tightening of screw-type couplings to the limit stop of the thread. Forced or improper separation will result in malfunction of the coupling.



Series HS • Dust Protection

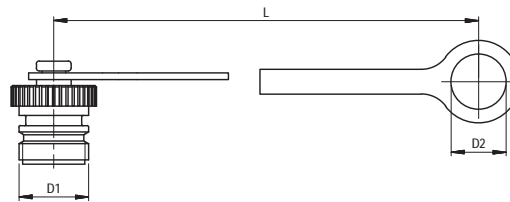
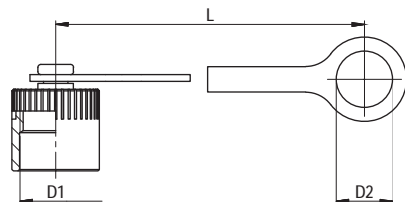

Dimensions (mm/in)			Material	Dust Cap for Female Body	
D1	D2	L		Old Part Numbers	STAUFF Ordering Codes
M24x2	19	180	Plastic (Colour: Red)	HS04-0-RT001	
	.75	7.09		QRC-HS-06-DF-19-K-RD	
M28x2	23	180	Plastic (Colour: Red)	HS08-0-RT001	
	.91	7.09		QRC-HS-10-DF-23-K-RD	
M36x2	29,5	185	Plastic (Colour: Red)	HS10-0-RT001	
	1.16	7.28		QRC-HS-12-DF-30-K-RD	
M42x2	36,5	190	Plastic (Colour: Red)	HS12-0-RT001	
	1.44	7.48		QRC-HS-19-DF-37-K-RD	
M48x3	41	190	Plastic (Colour: Red)	HS20-0-RT001	
	1.61	7.48		QRC-HS-25-DF-41-K-RD	
M70x3	55	201	Plastic (Colour: Red)	HS25-0-RT001	
	2.17	7.91		QRC-HS-38-DF-55-K-RD	

Dimensions (mm/in)			Material	Dust Plug for Male Tip	
D1	D2	L		Old Part Numbers	STAUFF Ordering Codes
M24x2	19	180	Plastic (Colour: Red)	HS04-9-RT001	
	.75	7.09		QRC-HS-06-DM-19-K-RD	
M28x2	23	180	Plastic (Colour: Red)	HS08-9-RT001	
	.91	7.09		QRC-HS-10-DM-23-K-RD	
M36x2	29,5	185	Plastic (Colour: Red)	HS10-9-RT001	
	1.16	7.28		QRC-HS-12-DM-30-K-RD	
M42x2	36,5	190	Plastic (Colour: Red)	HS12-9-RT001	
	1.44	7.48		QRC-HS-19-DM-37-K-RD	
M48x3	41	190	Plastic (Colour: Red)	HS20-9-RT001	
	1.61	7.48		QRC-HS-25-DM-41-K-RD	
M70x3	55	201	Plastic (Colour: Red)	HS25-9-RT001	
	2.17	7.91		QRC-HS-38-DM-55-K-RD	

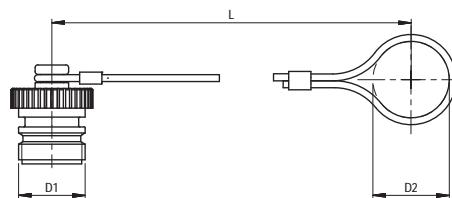
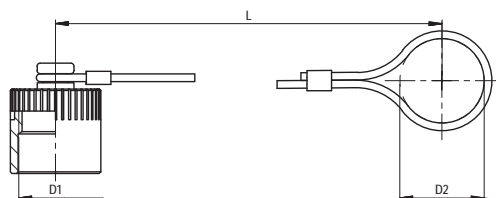

Dimensions (mm/in)			Material	Dust Cap for Female Body	
D1	D2	L		Old Part Numbers	STAUFF Ordering Codes
M24x2			Aluminium with steel cable	HS04-0-SI001	
				QRC-HS-06-DF-19-W89-SI	
M28x2			Aluminium with steel cable	HS08-0-SI001	
				QRC-HS-10-DF-23-W89-SI	
M36x2			Aluminium with steel cable	HS10-0-SI001	
				QRC-HS-12-DF-30-W89-SI	
M42x2			Aluminium with steel cable	HS12-0-SI001	
				QRC-HS-19-DF-37-W89-SI	
M48x3			Aluminium with steel cable	HS20-0-SI001	
				QRC-HS-25-DF-41-W89-SI	
M70x3			Aluminium with steel cable	HS25-0-SI001	
				QRC-HS-38-DF-55-W89-SI	

Dimensions (mm/in)			Material	Dust Plug for Male Tip	
D1	D2	L		Old Part Numbers	STAUFF Ordering Codes
M24x2			Aluminium with steel cable	HS04-9-SI001	
				QRC-HS-06-DM-19-W89-SI	
M28x2			Aluminium with steel cable	HS08-9-SI001	
				QRC-HS-10-DM-23-W89-SI	
M36x2			Aluminium with steel cable	HS10-9-SI001	
				QRC-HS-12-DM-30-W89-SI	
M42x2			Aluminium with steel cable	HS12-9-SI001	
				QRC-HS-19-DM-37-W89-SI	
M48x3			Aluminium with steel cable	HS20-9-SI001	
				QRC-HS-25-DM-41-W89-SI	
M70x3			Aluminium with steel cable	HS25-9-SI001	
				QRC-HS-38-DM-55-W89-SI	

In addition to the standard colours as stated above, plastic dust caps are also available in blue, green, yellow and black. Please use the old color codes BL, GN, GE and SW respectively instead of RT. Please use the STAUFF codes BU, GN, YE and BK respectively instead of RD.

HS



Series HS • Stainless Steel

Series HS • Overview	126
Series HS-06 • BG 1 • Nominal Size 6,3	127
Series HS-10 • BG 2 • Nominal Size 10	127
Series HS-12 • BG 3 • Nominal Size 12,5	127
Series HS-19 • BG 6 • Nominal Size 19	127
Series HS-25 • BG 8 • Nominal Size 25	128
Series HS-38 • BG 12 • Nominal Size 38	128

Series HS • Dust Protection	129
-----------------------------	-----



HS



Series HS ▪ Stainless Steel

Material	Stainless Steel V4A (AISI 316)
Surface Finishing	-
Standard Seal Material(s)	FKM (Viton®) ²
Working Temperature	-25° C ... +200° C / -13° F ... +392° F
Valve Design	Poppet Valve
Connection	Screw
Disconnection	Screw
Connect Under Pressure	Male Tip/Female Body up to 33% of the Working Pressure with Tools
Application	Agricultural and Forestry Machinery, Construction Machinery, Industrial Hydraulic
ISO Interchange	ISO 14541 (BG 1-6)



²Alternative seal materials are available on request.

Technical Data

Series	BG	DN Zoll Inch	DN metric ISO 4397	Q _{max}		Working Pressure		Bursting Pressure Connected		Female Body		Male Tip		Spillage	
				l/min	US GPM	bar	PSI	bar	PSI	bar	PSI	bar	PSI	ml	fl oz
HS-06	1	1/4"	6,3	17	4.49	300	4351	1200	17404	1200	17404	1200	17404	0,8	.0271
HS-10	2	3/8"	10	30	7.92	250	3626	1500	21756	1400	20305	1000	14504	1,9	.0642
HS-12	3	1/2"	12,5	80	21.13	250	3626	1800	26107	1800	26107	1100	15954	2,7	.0913
HS-19	6	3/4"	19 (20)	106	28.00	150	2175	1700	24657	700	10153	600	8702	9,3	.3145
HS-25	8	1"	25	189	49.93	150	2175	1200	17404	600	8702	600	8702	16	.5410
HS-38	12	1 1/2"	38	350	92.46	100	1450	400	5801	400	5801	400	5801	30	1.0144

The indicated pressure ratings only apply to the coupling itself and depend on the connection type.

Flow Characteristics

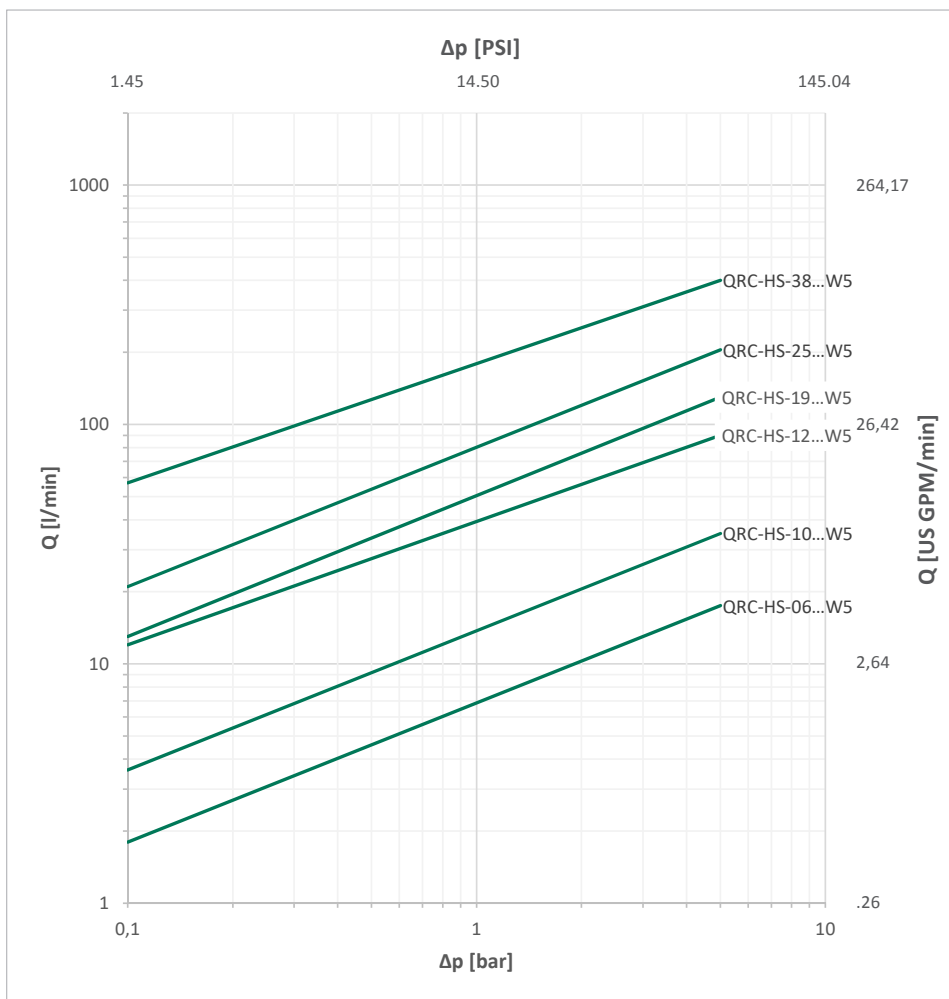

Please note: Unless otherwise stated, all flow characteristics have been determined with hydraulic oil with a kinematic viscosity of 28,8 - 35,2 mm²/s (28,8 - 35,2 cSt) and are only valid for components with non-reducing connections.



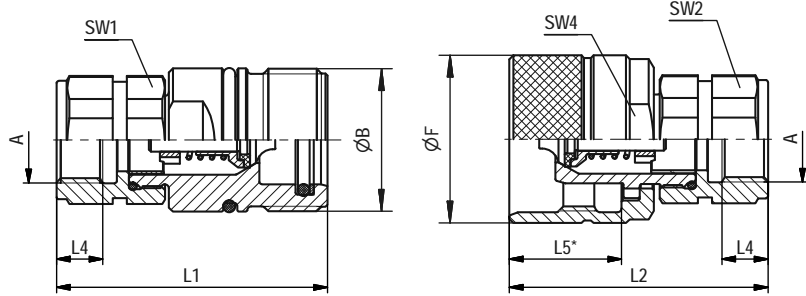

SW: Width across flats. All dimensions in mm (inch). Drawing similar Series HS-12.
* Insertion Female Body.

Series HS-06 ▪ BG 1 ▪ Nominal Size 6,3

Port A	Dimensions (mm/in)	Female Body									Weight (^{kg} /lbs) ca. per 100	Male Tip		Weight (^{kg} /lbs) ca. per 100
		ØB	ØF	L1	L2	L4 min	L5	SW1	SW2	SW4		Old Part Numbers	Old Part Numbers	
Female Thread according to DIN 3852														
	G 1/4"	M24x2	30	59,1	58	12	25,1	19	19	27	HS06-1-IGF04-VA	12,20	HS06-2-IGF04-VA	13
			1.18	2.33	2.28	.47	.99	.75	.75	1.06	QRC-HS-06-F-G04-VT-W5	26.90	QRC-HS-06-M-G04-V-W5	28.66

Series HS-10 ▪ BG 2 ▪ Nominal Size 10

Port A	Dimensions (mm/in)	Female Body									Weight (^{kg} /lbs) ca. per 100	Male Tip		Weight (^{kg} /lbs) ca. per 100
		ØB	ØF	L1	L2	L4 min	L5	SW1	SW2	SW4		Old Part Numbers	Old Part Numbers	
Female Thread according to DIN 3852														
	G 3/8"	M28x2	34	64,5	62	12	26,5	22	22	30	HS10-1-IGF06-VA	16,30	HS10-2-IGF06-VA	17,40
			1.34	2.54	2.44	.47	1.04	.87	.87	1.18	QRC-HS-10-F-G06-VT-W5	35.94	QRC-HS-10-M-G06-V-W5	38.36

Series HS-12 ▪ BG 3 ▪ Nominal Size 12,5

Port A	Dimensions (mm/in)	Female Body									Weight (^{kg} /lbs) ca. per 100	Male Tip		Weight (^{kg} /lbs) ca. per 100
		ØB	ØF	L1	L2	L4 min	L5	SW1	SW2	SW4		Old Part Numbers	Old Part Numbers	
Female Thread according to DIN 3852														
	G 3/8"	M36x2	41,8	67	63	12	28	30	30	38	HS12-1-IGF06-VA	33,10	HS12-2-IGF06-VA	30,50
			1.64	2.64	2.48	.47	1.1	1.18	1.18	1.49	QRC-HS-12-F-G06-VT-W5	72.97	QRC-HS-12-M-G06-V-W5	67.24
	G 1/2"	M36x2	41,8	67	63	12	28	30	30	38	HS12-1-IGF08-VA	31,20	HS12-2-IGF08-VA	28,10
			1.64	2.64	2.48	.47	1.1	1.18	1.18	1.49	QRC-HS-12-F-G08-VT-W5	68.78	QRC-HS-12-M-G08-V-W5	61.95

Series HS-19 ▪ BG 6 ▪ Nominal Size 19

Port A	Dimensions (mm/in)	Female Body									Weight (^{kg} /lbs) ca. per 100	Male Tip		Weight (^{kg} /lbs) ca. per 100
		ØB	ØF	L1	L2	L4 min	L5	SW1	SW2	SW4		Old Part Numbers	Old Part Numbers	
Female Thread according to DIN 3852														
	G 3/4"	M42x2	48	82	75	16	21	36	36	41	HS19-1-IGF12-VA	51,10	HS19-2-IGF12-VA	44,10
			1.89	3.23	2.95	.63	.83	1.42	1.42	1.61	QRC-HS-19-F-G12-VT-W5	112.66	QRC-HS-19-M-G12-V-W5	97.22

Note: The connection of the two halves of a coupling is achieved depending on the type. It is important to observe the positive engagement of plug-type couplings and the secure tightening of screw-type couplings to the limit stop of the thread. Forced or improper separation will result in malfunction of the coupling.



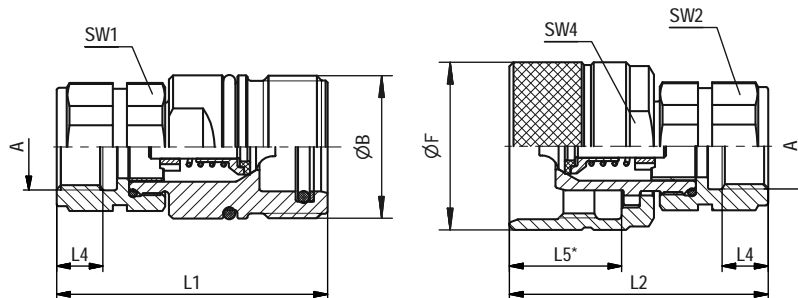

SW: Width across flats. All dimensions in mm (inch). Drawing similar Series HS-12.
* Insertion Female Body.

Series HS-25 • BG 8 • Nominal Size 25

Port A	Dimensions (mm/in)	Female Body									Weight (*9_nbs) ca. per 100	Male Tip Old Part Numbers STAUFF Ordering Codes	Weight (*9_nbs) ca. per 100	
		ØB	ØF	L1	L2	L4 min	L5	SW1	SW2	SW4				
Female Thread according to DIN 3852														
	G 3/4"	M48x3	55	95	78,5	16	35,5	41	16	50	HS25-1-IGF12-VA	74,80	HS25-2-IGF12-VA	65,10
			2.16	3.74	3.09	.63	1.40	1.61	.63	1.97	QRC-HS-25-F-G12-VT-W5	164.91	QRC-HS-25-M-G12-V-W5	143.52
	G 1"	M48x3	55	95	78,5	18	35,5	41	18	50	HS25-1-IGF16-VA	71,30	HS25-2-IGF16-VA	61,50
			2.16	3.74	3.09	.71	1.40	1.61	.71	1.97	QRC-HS-25-F-G16-VT-W5	157.19	QRC-HS-25-M-G16-V-W5	135.58

Series HS-38 • BG 12 • Nominal Size 38

Port A	Dimensions (mm/in)	Female Body									Weight (*9_nbs) ca. per 100	Male Tip Old Part Numbers STAUFF Ordering Codes	Weight (*9_nbs) ca. per 100	
		ØB	ØF	L1	L2	L4 min	L5	SW1	SW2	SW4				
Female Thread according to DIN 3852														
	G 1 1/4"	M70x3	80	116	121	20	44	60	20	65	HS38-1-IGF20-VA	180,20	HS38-2-IGF20-VA	235
			3.12	4.57	4.76	.79	1.73	2.36	.79	2.56	QRC-HS-38-F-G20-VT-W5	397.27	QRC-HS-38-M-G20-V-W5	518.09
	G 1 1/2"	M70x3	80	116	121	22	44	60	22	65	HS38-1-IGF24-VA	173	HS38-2-IGF24-VA	227,80
			3.12	4.57	4.76	.87	1.73	2.36	.87	2.56	QRC-HS-38-F-G24-VT-W5	381.40	QRC-HS-38-M-G24-V-W5	502,21

HS

Note: The connection of the two halves of a coupling is achieved depending on the type. It is important to observe the positive engagement of plug-type couplings and the secure tightening of screw-type couplings to the limit stop of the thread. Forced or improper separation will result in malfunction of the coupling.

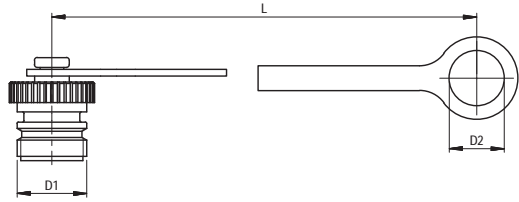
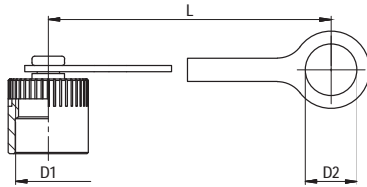

Series HS • Dust Protection

Dimensions (mm/in)			Material	Dust Cap for Female Body	
D1	D2	L		Old Part Numbers	STAUFF Ordering Codes
M24x2	19	180	Plastic (Colour: Red)	HS04-0-RT001	
	.75	7.09		QRC-HS-06-DF-19-K-RD	
M28x2	23	180	Plastic (Colour: Red)	HS08-0-RT001	
	.91	7.09		QRC-HS-10-DF-23-K-RD	
M36x2	29,5	185	Plastic (Colour: Red)	HS10-0-RT001	
	1.16	7.28		QRC-HS-12-DF-30-K-RD	
M42x2	36,5	190	Plastic (Colour: Red)	HS12-0-RT001	
	1.44	7.48		QRC-HS-19-DF-37-K-RD	
M48x3	41	190	Plastic (Colour: Red)	HS20-0-RT001	
	1.61	7.48		QRC-HS-25-DF-41-K-RD	
M70x3	55	201	Plastic (Colour: Red)	HS25-0-RT001	
	2.17	7.91		QRC-HS-38-DF-55-K-RD	

Dimensions (mm/in)			Material	Dust Plug for Male Tip	
D1	D2	L		Old Part Numbers	STAUFF Ordering Codes
M24x2	19	180	Plastic (Colour: Red)	HS04-9-RT001	
	.75	7.09		QRC-HS-06-DM-19-K-RD	
M28x2	23	180	Plastic (Colour: Red)	HS08-9-RT001	
	.91	7.09		QRC-HS-10-DM-23-K-RD	
M36x2	29,5	185	Plastic (Colour: Red)	HS10-9-RT001	
	1.16	7.28		QRC-HS-12-DM-30-K-RD	
M42x2	36,5	190	Plastic (Colour: Red)	HS12-9-RT001	
	1.44	7.48		QRC-HS-19-DM-37-K-RD	
M48x3	41	190	Plastic (Colour: Red)	HS20-9-RT001	
	1.61	7.48		QRC-HS-25-DM-41-K-RD	
M70x3	55	201	Plastic (Colour: Red)	HS25-9-RT001	
	2.17	7.91		QRC-HS-38-DM-55-K-RD	

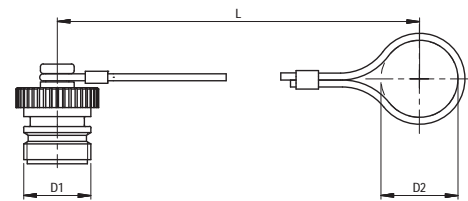
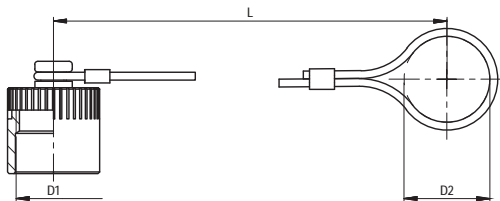

Dimensions (mm/in)			Material	Dust Cap for Female Body	
D1	D2	L		Old Part Numbers	STAUFF Ordering Codes
M24x2			Aluminium with steel cable	HS04-0-SI001	
				QRC-HS-06-DF-19-W89-SI	
M28x2			Aluminium with steel cable	HS08-0-SI001	
				QRC-HS-10-DF-23-W89-SI	
M36x2			Aluminium with steel cable	HS10-0-SI001	
				QRC-HS-12-DF-30-W89-SI	
M42x2			Aluminium with steel cable	HS12-0-SI001	
				QRC-HS-19-DF-37-W89-SI	
M48x3			Aluminium with steel cable	HS20-0-SI001	
				QRC-HS-25-DF-41-W89-SI	
M70x3			Aluminium with steel cable	HS25-0-SI001	
				QRC-HS-38-DF-55-W89-SI	

Dimensions (mm/in)			Material	Dust Plug for Male Tip	
D1	D2	L		Old Part Numbers	STAUFF Ordering Codes
M24x2			Aluminium with steel cable	HS04-9-SI001	
				QRC-HS-06-DM-19-W89-SI	
M28x2			Aluminium with steel cable	HS08-9-SI001	
				QRC-HS-10-DM-23-W89-SI	
M36x2			Aluminium with steel cable	HS10-9-SI001	
				QRC-HS-12-DM-30-W89-SI	
M42x2			Aluminium with steel cable	HS12-9-SI001	
				QRC-HS-19-DM-37-W89-SI	
M48x3			Aluminium with steel cable	HS20-9-SI001	
				QRC-HS-25-DM-41-W89-SI	
M70x3			Aluminium with steel cable	HS25-9-SI001	
				QRC-HS-38-DM-55-W89-SI	

In addition to the standard colours as stated above, plastic dust caps are also available in blue, green, yellow and black. Please use the old color codes BL, GN, GE and SW respectively instead of RT. Please use the STAUFF codes BU, GN, YE and BK respectively instead of RD.

HS



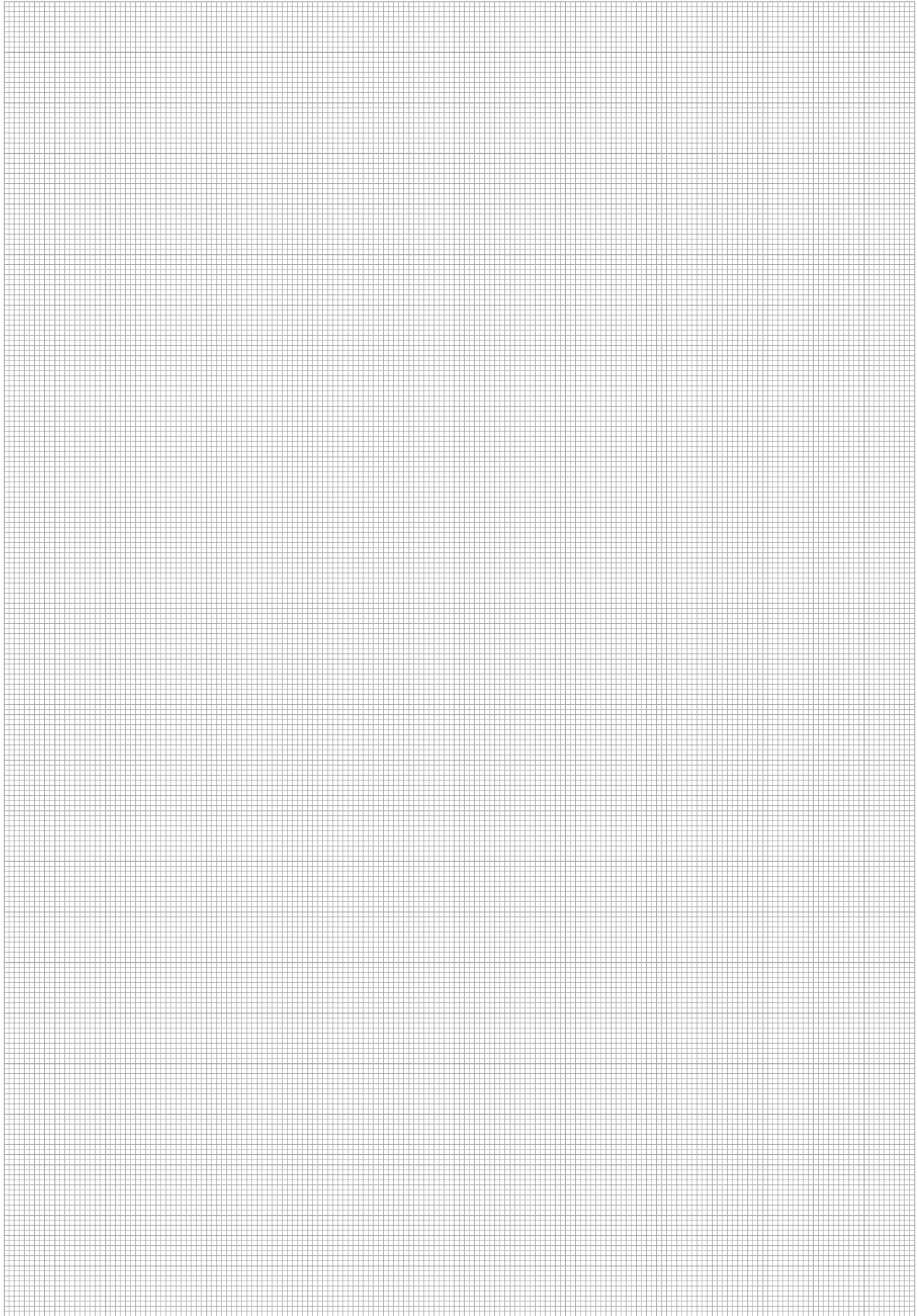

HS



Series PS • Carbon Steel

Series PS • Overview	132
Series PS-25 • BG 10 • Nominal Size 31,5	133
Series PS • Dust Protection	133



PS



Series PS ▪ Carbon Steel

Material	Carbon Steel
Surface Finishing	Zinc-Nickel
Standard Seal Material(s)	HNBR, FKM (Viton®), PTFE ²
Working Temperature	-20° C ... +100° C / -4° F ... +212° F
Valve Design	Poppet Valve
Connection	Screw
Disconnection	Screw
Connect Under Pressure	not allowed
Application	Construction Machinery
ISO Interchange	-



²Alternative seal materials are available on request.

Technical Data

Series	BG	DN Zoll	DN metric ISO 4397	Q _{max} l/min	US GPM	Working Pressure		Bursting Pressure Connected		Female Body		Male Tip		Spillage	
						bar	PSI	bar	PSI	bar	PSI	bar	PSI	ml	fl oz
PS-25	10	1 1/4"	31,5	600 (1000)*	158.50	380	5511	1520	22046	1520	22046	1520	22046	27	.9130

The indicated pressure ratings only apply to the coupling itself and depend on the connection type.

* short term possible

Flow Characteristics

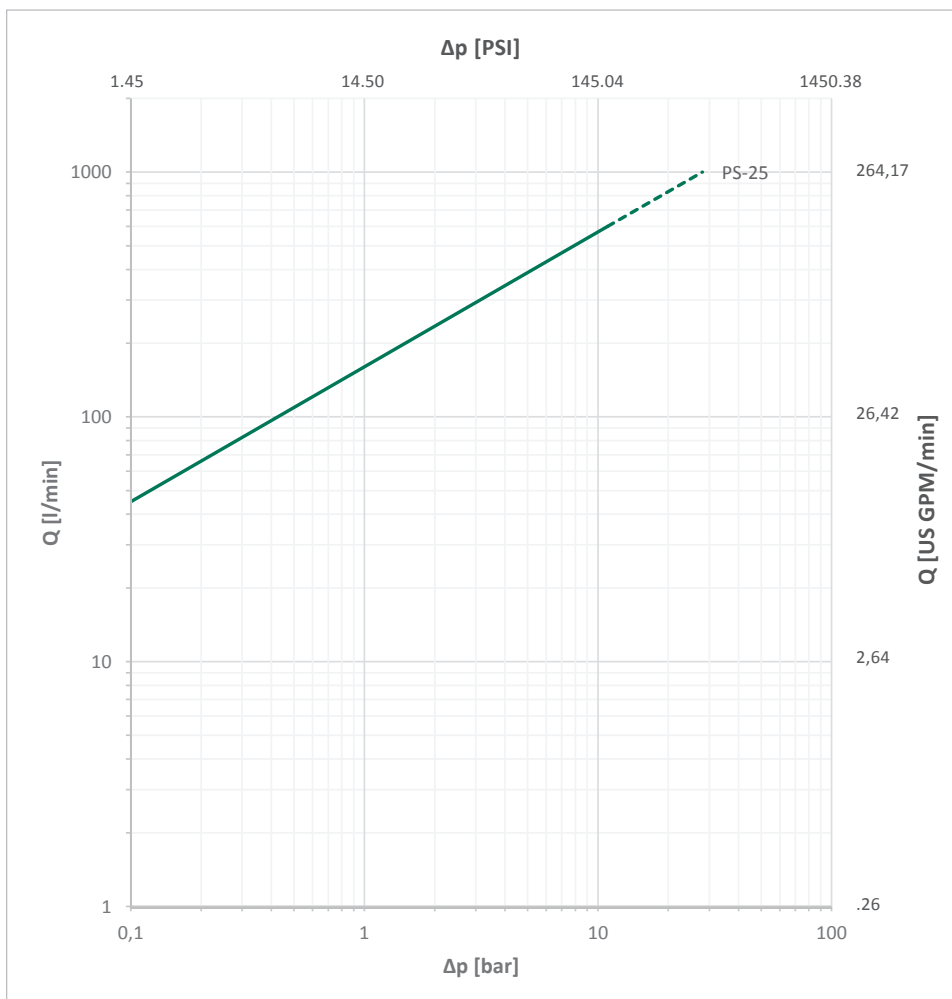

Please note: Unless otherwise stated, all flow characteristics have been determined with hydraulic oil with a kinematic viscosity of 28,8 - 35,2 mm²/s (28,8 - 35,2 cSt) and are only valid for components with non-reducing connections.



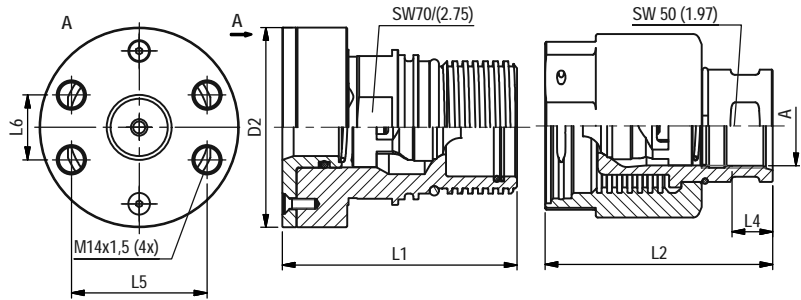

SW: Width across flats. All dimensions in mm (inch).

Series PS-25 • BG 10 • Nominal Size 31,5

Port A	Dimensions (^{mm} / _{in})							Female Body		Weight (^{kg} / _{lbs}) ca. per 100	Male Tip		Weight (^{kg} / _{lbs}) ca. per 100
	ØD2	L1	L2	L3	L4	L5	L6	Old Part Numbers	STAUFF Ordering Codes		Old Part Numbers	STAUFF Ordering Codes	
Flange SAE 6000 PSI													
	1" 1/4	98	115,5			66,7	31,8	PS31-1-AFS32	300,40				
			3.86	4.55		2,62	1.24	QRC-PS-25-F-C620M-S3-W3	662.27				
Female Thread according to SAE J1926-14													
	UN 1" 5/8 -12		112		19					PS-25-2-IUF20	262,60		
			4.41		.75					QRC-PS-25-M-U20-HB-W3	578.93		
Female Thread according to DIN 3852-2-A													
	G 1" 1/4	76	122	112		21,5		PS31-1-IGF20	244	PS31-2-IGF20	255,90		
		2.99	4.80	4.41		.85			QRC-PS-25-F-G20-S3-W3	537.93	QRC-PS-25-M-G20-HB-W3	564.16	

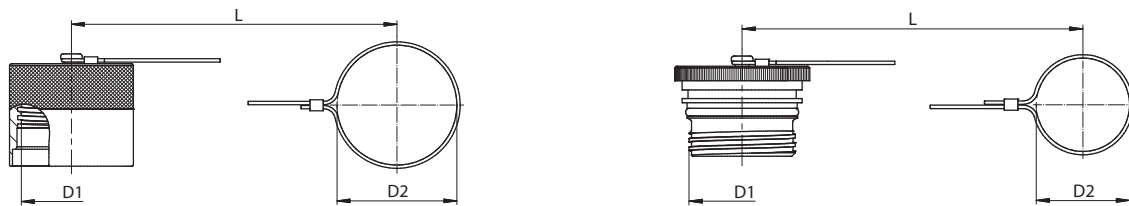
PS
Series PS • Dust Protection

Dimensions (^{mm} / _{in})			Material	Dust Cap for Female Body	
D1	D2	L		Old Part Numbers	STAUFF Ordering Codes
So.	80	280	Aluminium silver with steel cable	PS31-0-SI001	
65x5	3.15	11.02		QRC-PS-25-DF-80-W89-SI	

Dimensions (^{mm} / _{in})			Material	Dust Plug for Male Tip	
D1	D2	L		Old Part Numbers	STAUFF Ordering Codes
So.	56	240	Aluminium silver with steel cable	PS31-9-SI001	
65x5	2.20	9.45		QRC-PS-25-DM-56-W89-SI	

Note: The connection of the two halves of a coupling is achieved depending on the type. It is important to observe the positive engagement of plug-type couplings and the secure tightening of screw-type couplings to the limit stop of the thread. Forced or improper separation will result in malfunction of the coupling.



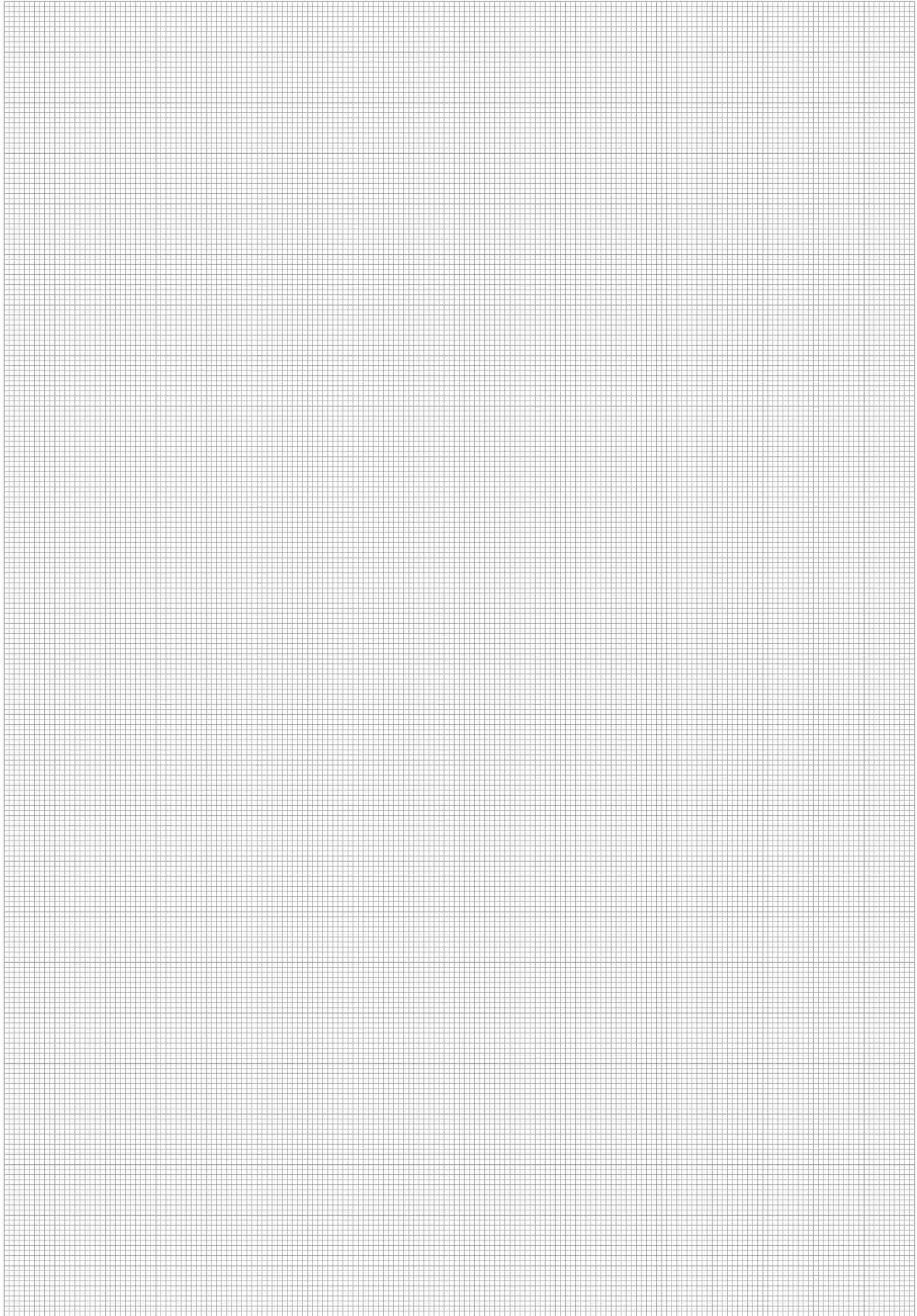

PS



Series RH/RK ▪ Carbon Steel

Series RH/RK ▪ Overview	136
Series RH-10 ▪ BG 2 ▪ Nominal Size 10	137
Series RH-12 ▪ BG 3 ▪ Nominal Size 12,5	137
Series RH-16 ▪ BG 4 ▪ Nominal Size 16	138
Series RK-19 ▪ BG 6 ▪ Nominal Size 19	138
Series RH-25 ▪ BG 8 ▪ Nominal Size 25	139
Series RH/RK ▪ Dust Protection	139



RH/RK



Series RH/RK • Carbon Steel

Material	Carbon Steel
Surface Finishing	Zinc-Nickel
Standard Seal Material(s)	NBR (Buna-N®), PTFE ²
Working Temperature	-20° C ... +100° C / -4° F ... +212° F
Valve Design	Flat Valve
Connection	Screw
Disconnection	Screw
Connect Under Pressure	Max. 20 bar / 290 PSI Residual Pressure with Tools allowed
Application	Construction Machinery
ISO Interchange	-



²Alternative seal materials are available on request.

Technical Data

Series	BG	DN Zoll Inch	DN metric ISO 4397	Q _{max}		Working Pressure*		Bursting Pressure Connected		Female Body		Male Tip		Spillage	
				l/min	US GPM	bar	PSI	bar	PSI	bar	PSI	bar	PSI	ml	fl oz
RH-10	2	3/8"	10	46	12.15	420	6092	1300	18855	1350	19580	1450	21030	0,1	.0034
RH-12	3	1/2"	12,5	90	23.78	420	6092	1260	18275	1260	18275	1260	18275	0,16	.0054
RH-16	4	5/8"	16	148	39.10	420	6092	1260	18275	1260	18275	1260	18275	1,02	.0344
RK-19	6	3/4"	19	200	52.83	350	5076	1000	14504	1000	14504	1200	17404	0,86	.0291
RH-25	8	1"	25	500	132.09	420	6092	1150	16679	1100	15954	900	13053	2,84	.0960

The indicated pressure ratings only apply to the coupling itself and depend on the connection type.
* in connected and disconnected condition.

Flow Characteristics

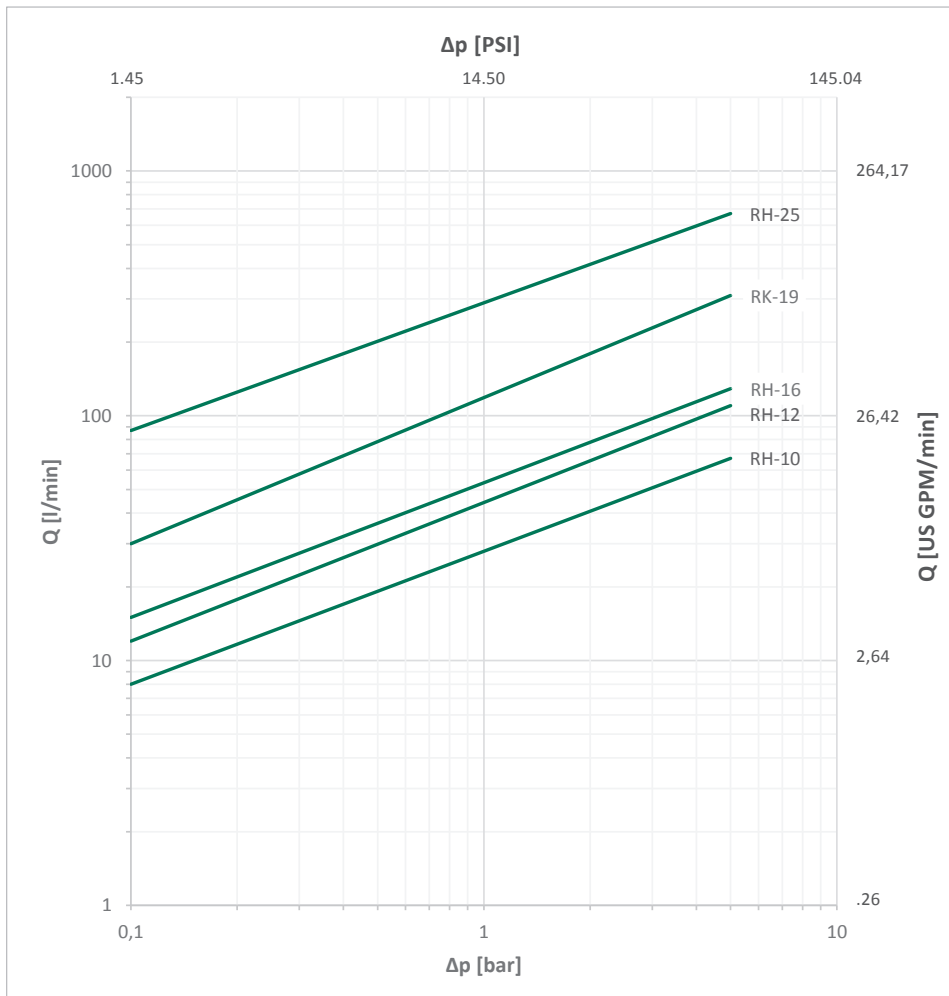

Please note: Unless otherwise stated, all flow characteristics have been determined with hydraulic oil with a kinematic viscosity of 28,8 - 35,2 mm²/s (28,8 - 35,2 cSt) and are only valid for components with non-reducing connections.



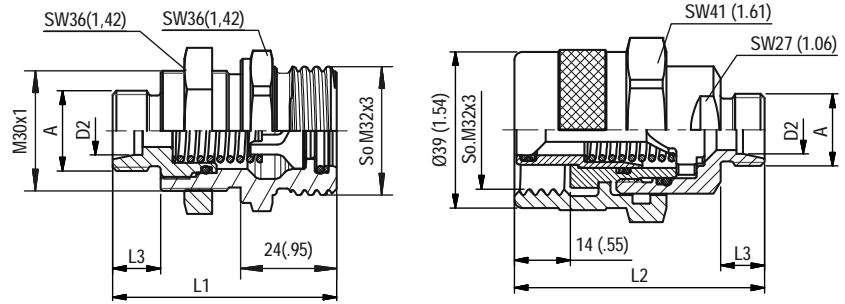

SW: Width across flats. All dimensions in mm (inch).

Series RH-10 • BG 2 • Nominal Size 10

Port A	Dimensions (^{mm} / _{in})					Female Body		Weight	Male Tip		Weight
	ØD2	L1	L2	L3	L4	Old Part Numbers	STAUFF Ordering Codes	(^{kg} / _{lbs}) ca. per 100	Old Part Numbers	STAUFF Ordering Codes	(^{kg} / _{lbs}) ca. per 100
Male Thread with 24° Conical Bore - Shape W according to DIN 3861											
	M14x1.5	8L	54	61	10	RH08-1-L0814		20,80	RH08-2-L0814		31,80
			2.13	2.40	.39	QRC-RH-10-F-08L-S1-W3		45.86	QRC-RH-10-M-08L-BT-W3		70.11
	M16x1.5	10L	55	61	11	RH08-1-L1016		21	RH08-2-L1016		32
			2.17	2.40	.43	QRC-RH-10-F-10L-S1-W3		46.30	QRC-RH-10-M-10L-BT-W3		70.55
	M18x1.5	12L	55	61	11	RH08-1-L1218		21,20	RH08-2-L1218		32,20
			2.17	2.40	.43	QRC-RH-10-F-12L-S1-W3		46.74	QRC-RH-10-M-12L-BT-W3		70.99
	M22x1.5	15L	56	62	12	RH08-1-L1522		22	RH08-2-L1522		32,90
			2.20	2.44	.47	QRC-RH-10-F-15L-S1-W3		48.50	QRC-RH-10-M-15L-BT-W3		72.53
	M18x1.5	10S	56	62	12	RH08-1-S1018		21,50	RH08-2-S1018		32,60
			2.20	2.44	.47	QRC-RH-10-F-10S-S1-W3		47.40	QRC-RH-10-M-10S-BT-W3		71.87
	M20x1.5	12S	56	62	12	RH08-1-S1220		22	RH08-2-S1220		33
			2.20	2.44	.47	QRC-RH-10-F-12S-S1-W3		48.50	QRC-RH-10-M-12S-BT-W3		72.75
	M22x1.5	14S	58	64	14	RH08-1-S1422		22,70	RH08-2-S1422		33,80
			2.28	2.52	.55	QRC-RH-10-F-14S-S1-W3		50.04	QRC-RH-10-M-14S-BT-W3		74.52
	M24x1.5	16S	58	64	14	RH08-1-S1624		23	RH08-2-S1624		33,90
			2.28	2.52	.55	QRC-RH-10-F-16S-S1-W3		50.71	QRC-RH-10-M-16S-BT-W3		74.74

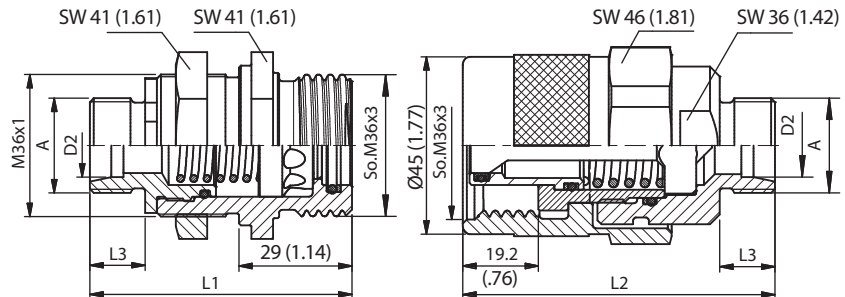

SW: Width across flats. All dimensions in mm (inch).

RH/RK
Series RH-12 • BG 3 • Nominal Size 12,5

Port A	Dimensions (^{mm} / _{in})					Female Body		Weight	Male Tip		Weight
	ØD2	L1	L2	L3	L4	Old Part Numbers	STAUFF Ordering Codes	(^{kg} / _{lbs}) ca. per 100	Old Part Numbers	STAUFF Ordering Codes	(^{kg} / _{lbs}) ca. per 100
Male Thread with 24° Conical Bore - Shape W according to DIN 3861											
	M22x1.5	15L	65	78	12	RH12-1-L1522		31,20	RH12-2-L1522		56,40
			2.56	3.07	.47	QRC-RH-12-F-15L-S1-W3		68.78	QRC-RH-12-M-15L-BT-W3		124.34
	M24x1.5	16S	67	80	14	RH12-1-S1624		32	RH12-2-S1624		57,30
			2.64	3.15	.55	QRC-RH-12-F-16S-S1-W3		70.55	QRC-RH-12-M-16S-BT-W3		126.32
	M30x2	20S	69,5	81,2	16	RH12-1-S2030		34,80	RH12-2-S2030		59,50
			2.74	3.20	.63	QRC-RH-12-F-20S-S1-W3		76.72	QRC-RH-12-M-20S-BT-W3		131.18

Note: The connection of the two halves of a coupling is achieved depending on the type. It is important to observe the positive engagement of plug-type couplings and the secure tightening of screw-type couplings to the limit stop of the thread. Forced or improper separation will result in malfunction of the coupling.



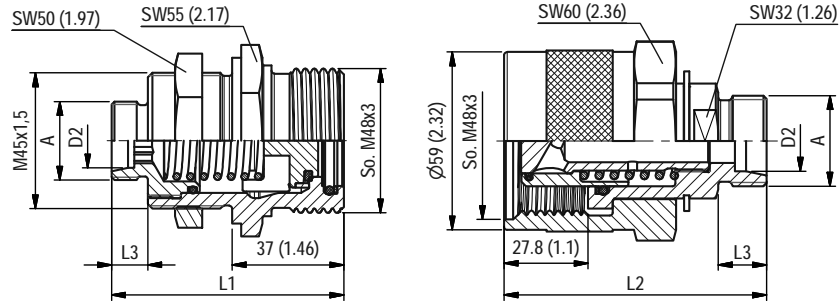

SW: Width across flats. All dimensions in mm (inch).

Series RH-16 • BG 4 • Nominal Size 16

Port A	Dimensions (mm/in)					Female Body	Weight	Male Tip	Weight
	ØD2	L1	L2	L3	L4	Old Part Numbers STAUFF Ordering Codes	(kg/nbs) ca. per 100	Old Part Numbers STAUFF Ordering Codes	(kg/nbs) ca. per 100
Male Thread with 24° Conical Bore - Shape W according to DIN 3861									
	M22x1,5	15L	77	77	12	RH16-1-L1522 QRC-RH-16-F-15L-S1-W3	61,40 135.36	RH16-2-L1522 QRC-RH-16-M-15L-BT-W3	94 207.23
	M26x1,5	18L	77	77	12	RH16-1-L1826 QRC-RH-16-F-18L-S1-W3	61,60 135.80	RH16-2-L1826 QRC-RH-16-M-18L-BT-W3	94,30 207.90
			3.03	3.03	.47				
	M24x1,5	16S	79	79	14	RH16-1-S1624 QRC-RH-16-F-16S-S1-W3	61,70 136.03	RH16-2-S1624 QRC-RH-16-M-16S-BT-W3	94,50 208.34
			3.11	3.11	.55				
	M30x2	20S	81	81	16	RH16-1-S2030 QRC-RH-16-F-20S-S1-W3	62 136.69	RH16-2-S2030 QRC-RH-16-M-20S-BT-W3	94,90 209.22
			3.19	3.19	.63				

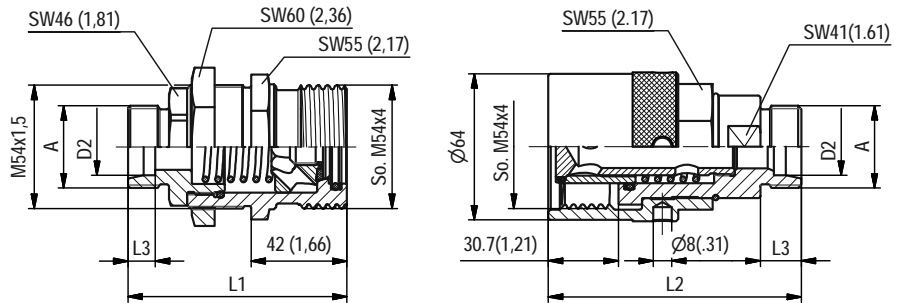

SW: Width across flats. All dimensions in mm (inch).

Series RK-19 • BG 6 • Nominal Size 19

Port A	Dimensions (mm/in)					Female Body	Weight	Male Tip	Weight
	ØD2	L1	L2	L3	L4	Old Part Numbers STAUFF Ordering Codes	(kg/nbs) ca. per 100	Old Part Numbers STAUFF Ordering Codes	(kg/nbs) ca. per 100
Male Thread with 24° Conical Bore - Shape W according to DIN 3861									
	M26x1,5	18L	90	103	12	RK19-1-L1826 QRC-RK-19-F-18L-S1-W3	88 194.01	RK19-2-L1826 QRC-RK-19-M-18L-BT-W3	128,80 283.96
			3.54	4.06	.47				
	M30x2	22L	92	105	14	RK19-1-L2230 QRC-RK-19-F-22L-S1-W3	88,80 195.77	RK19-2-L2230 QRC-RK-19-M-22L-BT-W3	129,60 285.72
			3.62	4.13	.55				
	M36x2	28L	92	107	14	RK19-1-L2836 QRC-RK-19-F-28L-S1-W3	90 198.42	RK19-2-L2836 QRC-RK-19-M-28L-BT-W3	130,60 287.92
			3.62	4.21	.55				
	M30x2	20S	95	109	16	RK19-1-S2030 QRC-RK-19-F-20S-S1-W3	92,20 203.27	RK19-2-S2030 QRC-RK-19-M-20S-BT-W3	131,60 290.13
			3.74	4.29	.63				
	M36x2	25S	97	111	18	RK19-1-S2536 QRC-RK-19-F-25S-S1-W3	93 205.03	RK19-2-S2536 QRC-RK-19-M-25S-BT-W3	132,30 291.67
			3.82	4.37	.71				
	M42x2	30S	99	113	20	RK19-1-S3042 QRC-RK-19-F-30S-S1-W3	95,80 211.20	RK19-2-S3042 QRC-RK-19-M-30S-BT-W3	134,30 296.08
			3.90	4.45	.79				

Note: The connection of the two halves of a coupling is achieved depending on the type. It is important to observe the positive engagement of plug-type couplings and the secure tightening of screw-type couplings to the limit stop of the thread. Forced or improper separation will result in malfunction of the coupling.



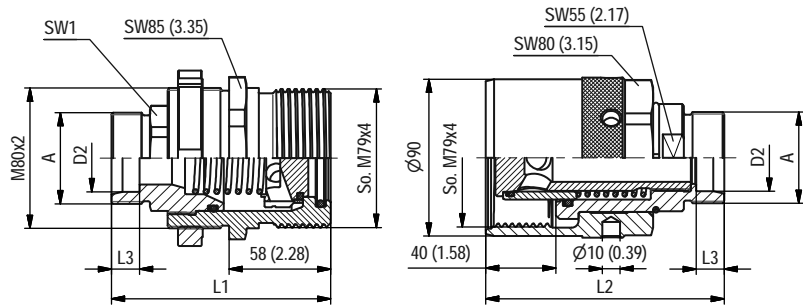

SW: Width across flats. All dimensions in mm (inch).

Series RH-25 • BG 8 • Nominal Size 25

Port A	Dimensions (^{mm} / _{in})						Female Body		Weight (^{kg} / _{lbs}) ca. per 100	Male Tip		Weight (^{kg} / _{lbs}) ca. per 100
	ØD2	L1	L2	L3	L4	SW1	Old Part Numbers	Old Part Numbers		STAUFF Ordering Codes	STAUFF Ordering Codes	
Male Thread with 24° Conical Bore - Shape W according to DIN 3861												
	M45x2	35L	122	136	16		46	RH25-1-L3545	273	RH25-2-L3545	335	
			4.80	5.35	.63		1.81	QRC-RH-25-F-35L-S1-W3	601.86	QRC-RH-25-M-35L-BT-W3	738.55	
	M52x2	42L	122	136	16		55	RH25-1-L4252	283	RH25-2-L4252	335	
			4.80	5.35	.63		2.17	QRC-RH-25-F-42L-S1-W3	623.91	QRC-RH-25-M-42L-BT-W3	738.55	
	M52x2	38S	125	136	22		55	RH25-1-S3852	285.50	RH25-2-S3852	334.50	
			4.92	5.35	.87		2.17	QRC-RH-25-F-38S-S1-W3	629.42	QRC-RH-25-M-38S-BT-W3	737.45	

Series RH/RK • Dust Protection

Dimensions (^{mm} / _{in})			Material	Dust Cap for Female Body	
D1	D2	L		Old Part Numbers	STAUFF Ordering Codes
M32x3	36,5	190	Plastic (Colour: Red)	RH08-0-RT001	
	1.44	7.48		QRC-RH-10-DF-37-K-RD	
M32x3	29,5	185	Plastic (Colour: Red)	RH08-0-RT006	
	1.16	7.28		QRC-RH-10-DF-30-K-RD	
M36x3	41	190	Plastic (Colour: Red)	RH12-0-RT001	
	1.61	7.48		QRC-RH-12-DF-41-K-RD	
M48x3	55	210	Plastic (Colour: Red)	RH16-0-RT001	
	2.17	8.27		QRC-RH-16-DF-55-K-RD	

Dimensions (^{mm} / _{in})			Material	Dust Plug for Male Tip	
D1	D2	L		Old Part Numbers	STAUFF Ordering Codes
M32x3	29,5	185	Plastic (Colour: Red)	RH08-9-RT001	
	1.16	7.28		QRC-RH-10-DM-30-K-RD	
M36x3	29,5	185	Plastic (Colour: Red)	RH12-9-RT001	
	1.16	7.28		QRC-RH-12-DM-30-K-RD	
M48x3	36,5	190	Plastic (Colour: Red)	RH16-9-RT001	
	1.44	7.48		QRC-RH-16-DM-37-K-RD	

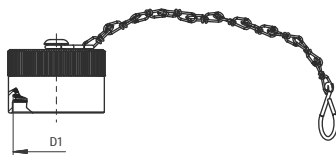
RH/RK

Dimensions (^{mm} / _{in})			Material	Dust Cap for Female Body	
D1	D2	L		Old Part Numbers	STAUFF Ordering Codes
So.			Aluminium silver with chain	RH16-0-SI001	
M48x3				QRC-RH-16-DF-CN-W89-SI	
So.			Aluminium silver with chain	RH20-0-SI001	
M54x4				QRC-RH-19-DF-CN-W89-SI	
So.			Aluminium silver with chain	RH25-0-SI001	
M79x4				QRC-RH-25-DF-CN-W89-SI	

Dimensions (^{mm} / _{in})			Material	Dust Plug for Male Tip	
D1	D2	L		Old Part Numbers	STAUFF Ordering Codes
So.			Aluminium silver with chain	RH16-9-SI001	
M48x3				QRC-RH-16-DM-CN-W89-SI	
So.			Aluminium silver with chain	RH20-9-SI001	
M54x4				QRC-RH-19-DM-CN-W89-SI	
So.			Aluminium silver with chain	RH25-9-SI001	
M79x4				QRC-RH-25-DM-CN-W89-SI	

In addition to the standard colours as stated above, plastic dust caps are also available in blue, green, yellow and black. Please use the old color codes BL, GN, GE and SW respectively instead of RT. Please use the STAUFF codes BU, GN, YE and BK respectively instead of RD.

Note: The connection of the two halves of a coupling is achieved depending on the type. It is important to observe the positive engagement of plug-type couplings and the secure tightening of screw-type couplings to the limit stop of the thread. Forced or improper separation will result in malfunction of the coupling.



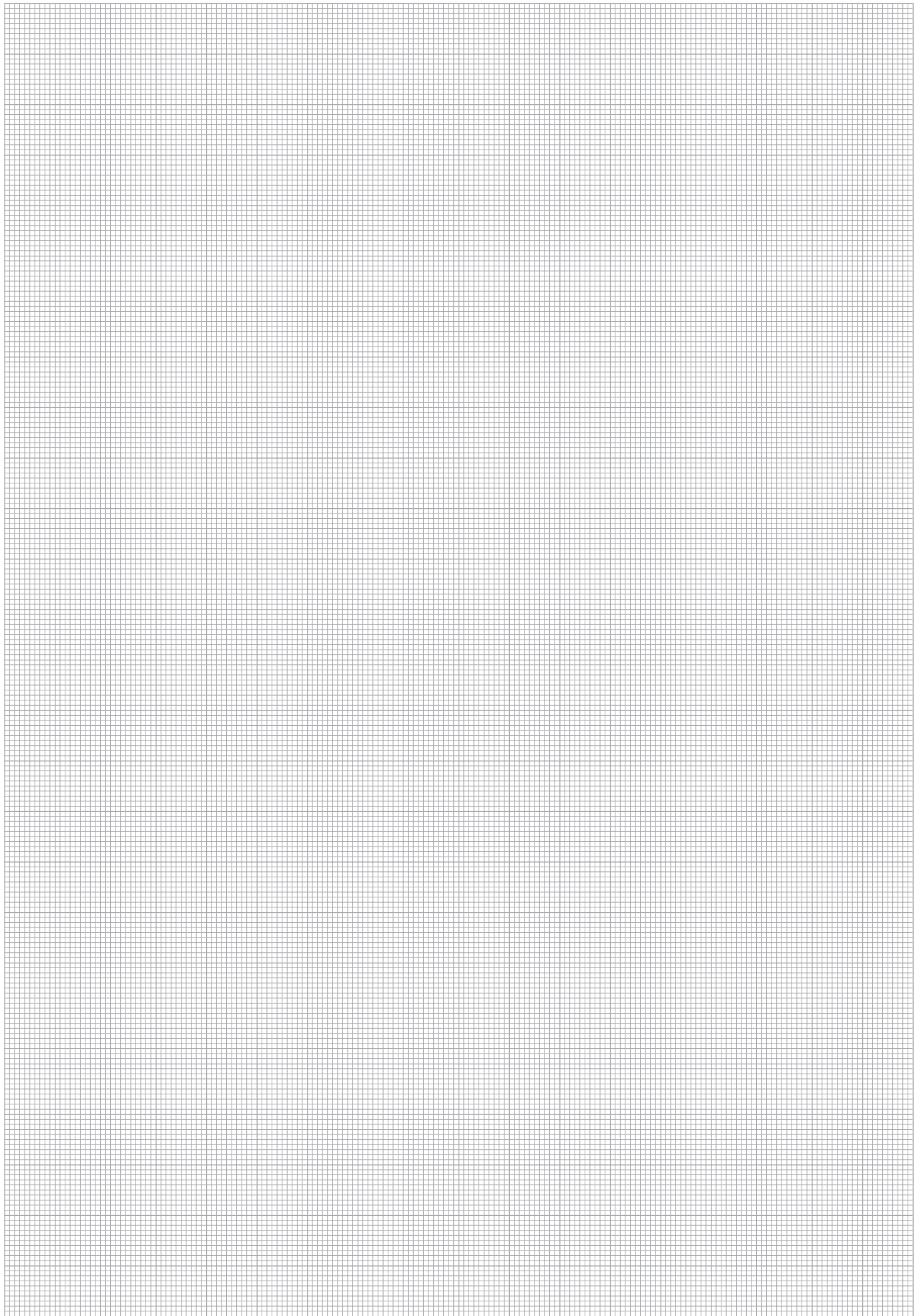

RH/RK



Series FT • Carbon Steel

Series FT • Overview	142
Series FT-10 • BG 2 • Nominal Size 10	143
Series FT-12 • BG 3 • Nominal Size 12,5	143
Series FT-16 • BG 4 • Nominal Size 16	144
Series FT-19 • BG 6 • Nominal Size 19	144
Series FT-25 • BG 8 • Nominal Size 25	145
Series FT-31 • BG 10 • Nominal Size 31,5	145

Series FT • Dust Protection	146
-----------------------------	-----



FT



Series FT • Carbon Steel

Material	Carbon Steel
Surface Finishing	Zinc-Nickel
Standard Seal Material(s)	NBR (Buna-N®), PTFE ²
Working Temperature	-25° C ... +100° C / -13° F ... +212° F
Valve Design	Flat Face
Connection	Screw
Disconnection	Screw
Connect Under Pressure	Male Tip up to the max. Working Pressure allowed
Application	Construction Machinery, Industrial Hydraulic
ISO Interchange	-



²Alternative seal materials are available on request.

Technical Data

Series	BG	DN Zoll Inch	DN metric ISO 4397	Q _{max}		Working Pressure		Bursting Pressure Connected		Female Body		Male Tip		Spillage	
				l/min	US GPM	bar	PSI	bar	PSI	bar	PSI	bar	PSI	ml	fl oz
FT-10	2	3/8"	10	80	21.13	550	7977	1400	20305	1100	15954	1400	20305	0,04	.0014
FT-12	3	1/2"	12,5	120	31.70	550	7977	1400	20305	1000	14504	1400	20305	0,025	.0008
FT-16	4	5/8"	16	140	36.98	550	7977	1400	20305	1000	14504	1600	23206		
FT-19	6	3/4"	19	180	47.55	500	7252	1400	20305	1050	15229	1400	20305	0,018	.0006
FT-25	8	1"	25	260	68.68	470	6817	1300	18855	1000	14504	1300	18855	0,06	.0020
FT-31	10	1 1/4"	31,5	600	158.50	400	5801	1100	15954	1100	15954	1100	15954		

The indicated pressure ratings only apply to the coupling itself and depend on the connection type.

Flow Characteristics

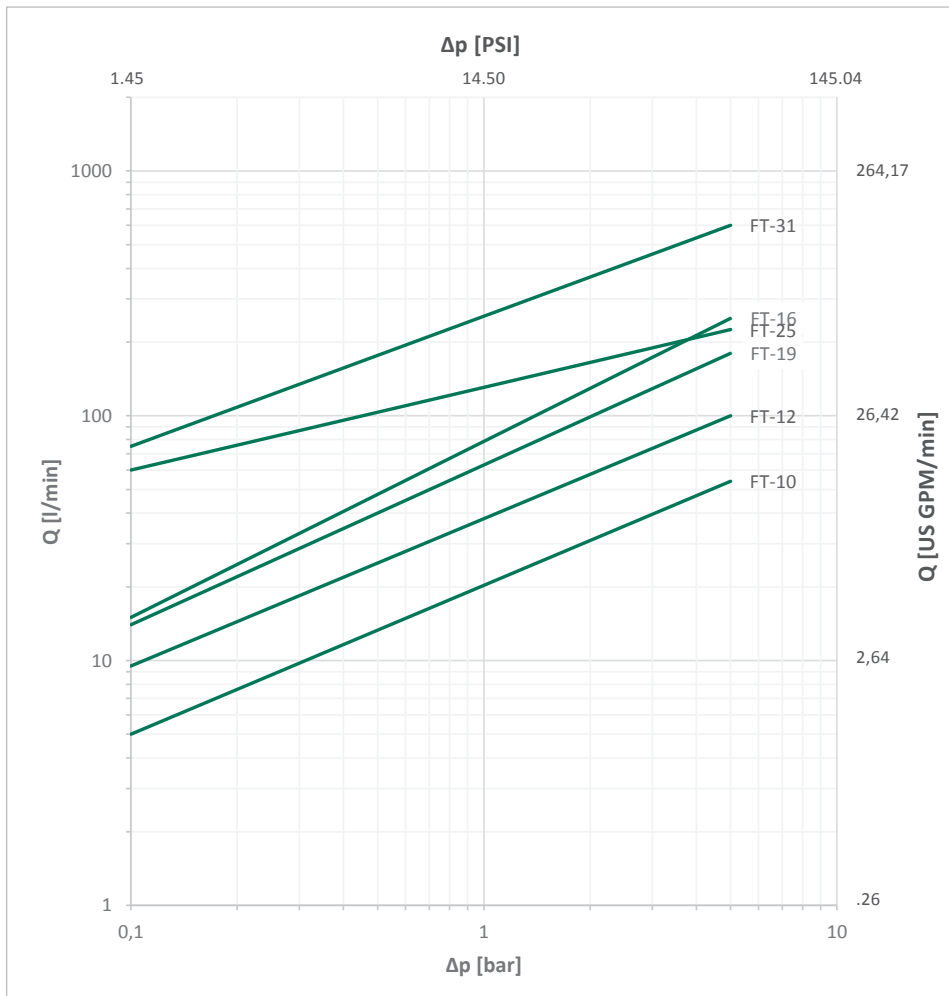

Please note: Unless otherwise stated, all flow characteristics have been determined with hydraulic oil with a kinematic viscosity of 28,8 - 35,2 mm²/s (28,8 - 35,2 cSt) and are only valid for components with non-reducing connections.

FT



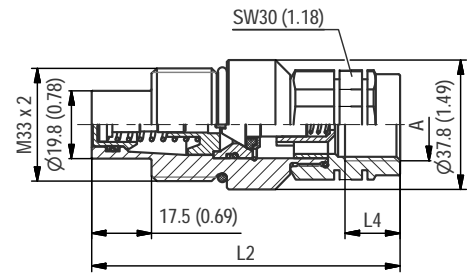
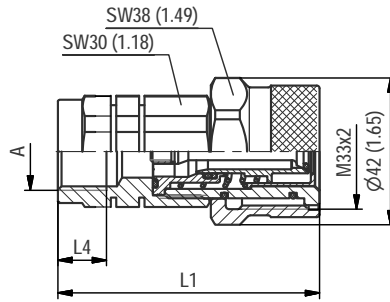

SW: Width across flats. All dimensions in mm (inch).

Series FT-10 • BG 2 • Nominal Size 10

Port A	Dimensions (mm/in)				Female Body	Weight	Male Tip	Weight
	ØD2	L1	L2	L3	Old Part Numbers STAUFF Ordering Codes	(^{kg} / _{lbs}) ca. per 100	Old Part Numbers STAUFF Ordering Codes	(^{kg} / _{lbs}) ca. per 100
Female Thread according to DIN 3852-2 - ANSI B 1.20.3 - SAE J1926-1								
	G 3/8"	70	87	12	FT10-1-IGF06 QRC-FT-10-F-G06-BT-W3	36 79.37	FT10-2-IGF06 QRC-FT-10-M-G06-BT-W3	38,40 84.66
	G 1/2"	75	90	14	FT10-1-IGF08 QRC-FT-10-F-G08-BT-W3	36,50 80.47	FT10-2-IGF08 QRC-FT-10-M-G08-BT-W3	37,90 83.56
	NPTF 3/8" -18	75	90		FT10-1-INF06 QRC-FT-10-F-NF06-BT-W3	38,30 84.44	FT10-2-INF06 QRC-FT-10-M-NF06-BT-W3	39,70 87.52
	NPTF 1/2" -14	75	90		FT10-1-INF08 QRC-FT-10-F-NF08-BT-W3	36,90 81.35	FT10-2-INF08 QRC-FT-10-M-NF08-BT-W3	38,50 84.89
	UNF 3/4" -16	75	87	14,3	FT10-1-IUF08 QRC-FT-10-F-U08-BT-W3	37,30 82.23	FT10-2-IUF08 QRC-FT-10-M-U08-BT-W3	37,50 82.67
		2.95	3.43	.56				

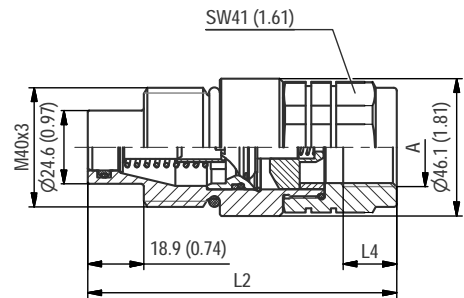
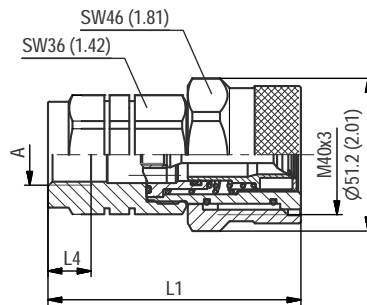

SW: Width across flats. All dimensions in mm (inch).

Series FT-12 • BG 3 • Nominal Size 12,5

Port A	Dimensions (mm/in)				Female Body	Weight	Male Tip	Weight
	ØD2	L1	L2	L3	Old Part Numbers STAUFF Ordering Codes	(^{kg} / _{lbs}) ca. per 100	Old Part Numbers STAUFF Ordering Codes	(^{kg} / _{lbs}) ca. per 100
Female Thread according to DIN 3852-2 - ANSI B 1.20.3 - SAE J1926-1								
	G 1/2"	85	98	14,5	FT12-1-IGF08 QRC-FT-12-F-G08-BT-W3	65,70 144.84	FT12-2-IGF08 QRC-FT-12-M-G08-BT-W3	67,10 147.93
		3.35	3.86	.57				
	G 3/4"	85	104	16	FT12-1-IGF12 QRC-FT-12-F-G12-BT-W3	62,50 137.79	FT12-2-IGF12 QRC-FT-12-M-G12-BT-W3	69,10 152.34
		3.35	4.09	.63				
	NPTF 1/2" -14	85	104		FT12-1-INF08 QRC-FT-12-F-NF08-BT-W3	61,70 136.03	FT12-2-INF08 QRC-FT-12-M-NF08-BT-W3	73,10 161.16
		3.35	4.09					
	NPTF 3/4" -14	85	104		FT12-1-INF12 QRC-FT-12-F-NF12-BT-W3	63 138.89	FT12-2-INF12 QRC-FT-12-M-NF12-BT-W3	67,50 148.81
		3.35	4.09					
	UNF 3/4" -16	85	98	16	FT12-1-IUF08 QRC-FT-12-F-U08-BT-W3	65,80 145.06	FT12-2-IUF08 QRC-FT-12-M-U08-BT-W3	69,60 153.44
		3.35	3.86	.63				
UN 1" 1/16 -12	85	104	19	FT12-1-IUF12 QRC-FT-12-F-U12-BT-W3	61 134.48	FT12-2-IUF12 QRC-FT-12-M-U12-BT-W3	68,50 151.02	
	3.35	4.09	.75					

FT

Note: The connection of the two halves of a coupling is achieved depending on the type. It is important to observe the positive engagement of plug-type couplings and the secure tightening of screw-type couplings to the limit stop of the thread. Forced or improper separation will result in malfunction of the coupling.



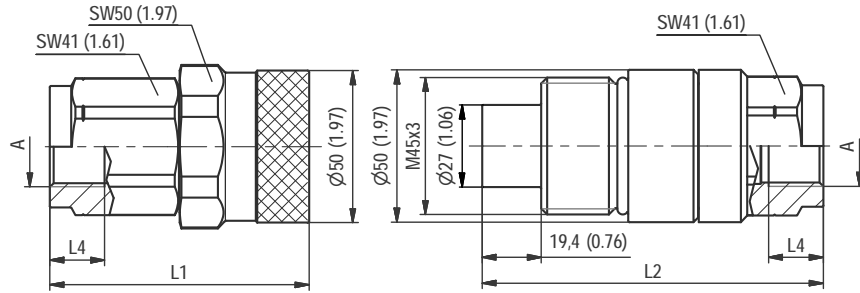

SW: Width across flats. All dimensions in mm (inch).

Series FT-16 • BG 4 • Nominal Size 16

Port A	Dimensions (mm/in)				Female Body		Weight	Male Tip		Weight
	ØD2	L1	L2	L3	L4	Old Part Numbers	(kg/lbs) ca.	Old Part Numbers	(kg/lbs) ca.	
					STAUFF Ordering Codes		per 100	STAUFF Ordering Codes		per 100
Female Thread according to 3852-2 - ANSI B 1.20.3 - SAE J1926-1										
	G 3/4"	85	112		16	FT16-1-IGF12	80,30	FT16-2-IGF12	96,30	
		3.35	4.41		.63	QRC-FT-16-F-G12-BT-W3	177.03	QRC-FT-16-M-G12-S2-W3	212.31	
	G 1"	87	114		18	FT16-1-IGF16	76,80	FT16-2-IGF16	92,80	
		3.43	4.49		.71	QRC-FT-16-F-G16-BT-W3	169.31	QRC-FT-16-M-G16-S2-W3	204.59	
	NPTF 3/4" -14	85	112			FT16-1-INF12	79,80	FT16-2-INF12	96,90	
		3.35	4.41			QRC-FT-16-F-NF12-BT-W3	175.93	QRC-FT-16-M-NF12-S2-W3	213.63	
	UN 1" 1/16 -12	85	112		19	FT16-1-IUF12	74,50	FT16-2-IUF12	95,60	
		3.35	4.41		.75	QRC-FT-16-F-U12-BT-W3	164.24	QRC-FT-16-M-U12-S2-W3	210.76	

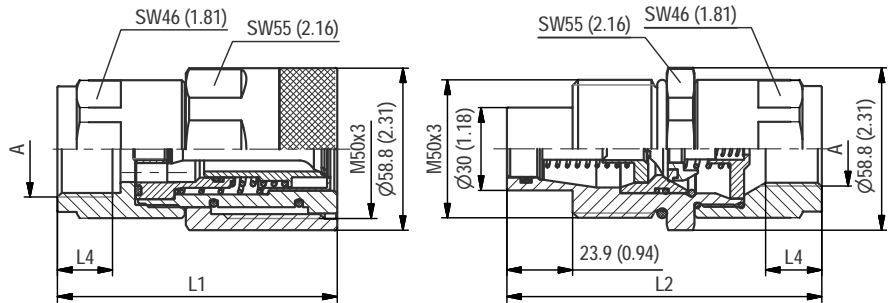

SW: Width across flats. All dimensions in mm (inch).

Series FT-19 • BG 6 • Nominal Size 19

Port A	Dimensions (mm/in)				Female Body		Weight	Male Tip		Weight
	ØD2	L1	L2	L3	L4	Old Part Numbers	(kg/lbs) ca.	Old Part Numbers	(kg/lbs) ca.	
					STAUFF Ordering Codes		per 100	STAUFF Ordering Codes		per 100
Female Thread according to DIN 3852-2 - ANSI B 1.20.3 - SAE J1926-1										
	G 3/4"	101	114		16	FT19-1-IGF12	135,50	FT19-2-IGF12	106,10	
		3.98	4.49		.63	QRC-FT-19-F-G12-BT-W3	298.73	QRC-FT-19-M-G12-BT-W3	233.91	
	G 1"	101	114		18	FT19-1-IGF16	129,80	FT19-2-IGF16	101,40	
		3.98	4.49		.71	QRC-FT-19-F-G16-BT-W3	286.16	QRC-FT-19-M-G16-BT-W3	223.55	
	NPTF 1" -11 1/2	101	114			FT19-1-INF16	132	FT19-2-INF16	102,80	
		3.98	4.49			QRC-FT-19-F-NF16-BT-W3	291.01	QRC-FT-19-M-NF16-BT-W3	226.64	
	UN 1" 5/16 -12	101	114		19	FT19-1-IUF16	129,70	FT19-2-IUF16	100,50	
		3.98	4.49		.75	QRC-FT-19-F-U16-BT-W3	285.94	QRC-FT-19-M-U16-BT-W3	221.56	

Note: The connection of the two halves of a coupling is achieved depending on the type. It is important to observe the positive engagement of plug-type couplings and the secure tightening of screw-type couplings to the limit stop of the thread. Forced or improper separation will result in malfunction of the coupling.



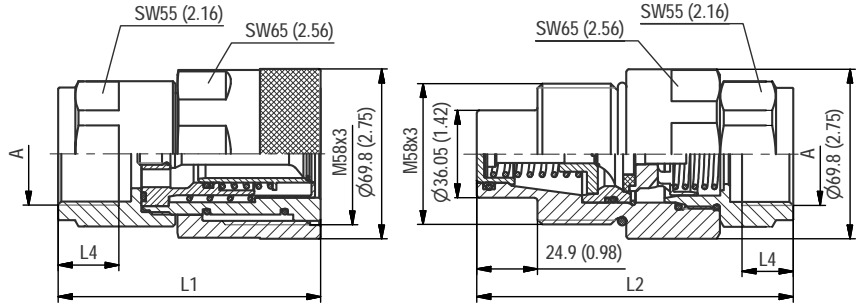

SW: Width across flats. All dimensions in mm (inch).

Series FT-25 • BG 8 • Nominal Size 25

Port A	Dimensions (mm/in)				Female Body	Weight	Male Tip	Weight	
	ØD2	L1	L2	L3	Old Part Numbers STAUFF Ordering Codes	(^{kg} / _{lbs}) ca. per 100	Old Part Numbers STAUFF Ordering Codes	(^{kg} / _{lbs}) ca. per 100	
Female Thread according to DIN 3852-2 - ANSI B 1.20.3 - SAE J1926-1									
	G 1" 1/4	108	130		20	FT25-1-IGF20	150,20	FT25-2-IGF20	189,70
		4.25	5.12		.79	QRC-FT-25-F-G20-BT-W3	331.13	QRC-FT-25-M-G20-BT-W3	418.22
	NPTF 1" 1/4 -11 1/2	108	130			FT25-1-INF20	153,90	FT25-2-INF20	191,90
		4.25	5.12			QRC-FT-25-F-NF20-BT-W3	339.29	QRC-FT-25-M-NF20-BT-W3	423.07
	UN 1" 5/8 -12	108	130		19	FT25-1-IUF20	152,30	FT25-2-IUF20	190,40
		4.25	5.12		.75	QRC-FT-25-F-U20-BT-W3	335.76	QRC-FT-25-M-U20-BT-W3	419.76

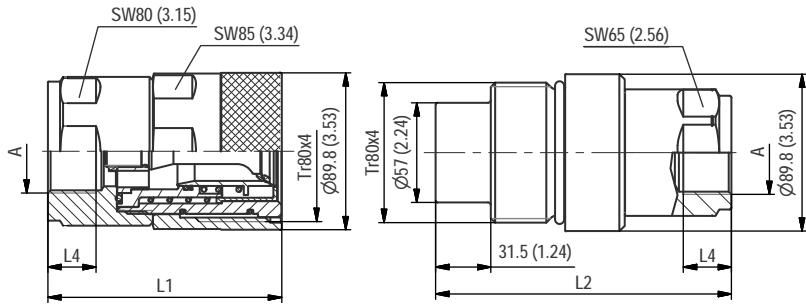

SW: Width across flats. All dimensions in mm (inch).

Series FT-31 • BG 10 • Nominal Size 31,5

Port A	Dimensions (mm/in)				Female Body	Weight	Male Tip	Weight	
	ØD2	L1	L2	L3	Old Part Numbers STAUFF Ordering Codes	(^{kg} / _{lbs}) ca. per 100	Old Part Numbers STAUFF Ordering Codes	(^{kg} / _{lbs}) ca. per 100	
Female Thread according to DIN 3852-2 - ANSI B 1.20.3 - SAE J1926-1									
	G 1" 1/2	134	169		22	FT32-1-IGF24	442,20	FT32-2-IGF24	402
		5.28	6.65		.87	QRC-FT-31-F-G24-S1-W3	974.88	QRC-FT-31-M-G24-S2-W3	886.26
	NPTF 1" 1/2 -11	134	169			FT32-1-INF24	444,20	FT32-2-INF24	404,10
		5.28	6.65			QRC-FT-31-F-NF24-S1-W3	979.29	QRC-FT-31-M-NF24-S2-W3	890.89
	UN 1" 7/8 -12	134	169		19	FT32-1-IUF24	439,20	FT32-2-IUF24	400,50
		5.28	6.65		.75	QRC-FT-31-F-U24-S1-W3	968.27	QRC-FT-31-M-U24-S2-W3	882.95

FT

Note: The connection of the two halves of a coupling is achieved depending on the type. It is important to observe the positive engagement of plug-type couplings and the secure tightening of screw-type couplings to the limit stop of the thread. Forced or improper separation will result in malfunction of the coupling.



Series FT • Dust Protection

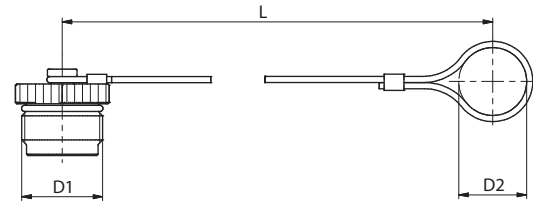
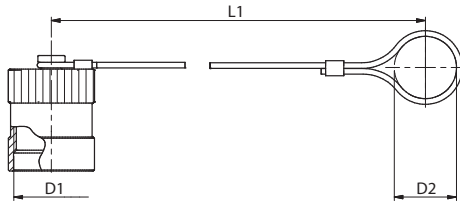

Dimensions (mm/in)			Material	Dust Cap for Male Tip	
D1	D2	L		Old Part Numbers	STAUFF Ordering Codes
M33x2	30	175	Aluminium silver with steel cable	FT10-0-SI001	QRC-FT-10-DM-30-W89-SI
	1.18	6.89			
M40x3	40,5	215	Aluminium silver with steel cable	FT12-0-SI001	QRC-FT-12-DM-41-W89-SI
	1.59	8.46			
M45x3	42,5	230	Aluminium silver with steel cable	FT16-0-SI001	QRC-FT-16-DM-43-W89-SI
	1.67	9.06			
M50x3	46	245	Aluminium silver with steel cable	FT19-0-SI001	QRC-FT-19-DM-46-W89-SI
	1.81	9.65			
M58x3	55	275	Aluminium silver with steel cable	FT25-0-SI001	QRC-FT-25-DM-55-W89-SI
	2.17	10.83			
TR80x4	71,5	350	Aluminium silver with steel cable	FT32-0-SI001	QRC-FT-31-DM-72-W89-SI
	2.81	13.78			

Dimensions (mm/in)			Material	Dust Plug for Female Body	
D1	D2	L		Old Part Numbers	STAUFF Ordering Codes
M33x2	30	175	Aluminium silver with steel cable	FT10-9-SI001	QRC-FT-10-DF-30-W89-SI
	1.18	6.89			
M40x3	36	215	Aluminium silver with steel cable	FT12-9-SI001	QRC-FT-12-DF-36-W89-SI
	1.42	8.46			
M45x3	42,5	230	Aluminium silver with steel cable	FT16-9-SI001	QRC-FT-16-DF-43-W89-SI
	1.67	9.06			
M50x3	46	245	Aluminium silver with steel cable	FT19-9-SI001	QRC-FT-19-DF-46-W89-SI
	1.81	9.65			
M58x3	55	275	Aluminium silver with steel cable	FT25-9-SI001	QRC-FT-25-DF-55-W89-SI
	2.17	10.83			
TR80x4	71,5	350	Aluminium silver with steel cable	FT32-9-SI001	QRC-FT-31-DF-72-W89-SI
	2.81	13.78			

FT



Series HR - Carbon Steel

Series HR - Overview	148
Series HR-10 - BG 2 - Nominal Size 10	149
Series HR-12 - BG 3 - Nominal Size 12,5	149
Series HR-19 - BG 6 - Nominal Size 19	149
Series HR-25 - BG 8 - Nominal Size 25	149
Series HR-31 - BG 10 - Nominal Size 31,5	150
Series HR-38 - BG 12 - Nominal Size 38	150

Series HR - Dust Protection	151
-----------------------------	-----



HR



Series HR ▪ Carbon Steel

Material	Carbon Steel
Surface Finishing	Zinc-Plating and Thick-Film-Passivation (Chrome III)
Standard Seal Material(s)	NBR (Buna-N®) ²
Working Temperature	-25° C ... +100° C / -13° F ... +212° F
Valve Design	Poppet Valve
Connection	Screw
Disconnection	Screw
Connect Under Pressure	Male Tip and Female Body up to max. 100 bar / 1450 PSI allowed
Application	Construction Machinery
ISO Interchange	-



²Alternative seal materials are available on request.

Technical Data

Series	BG	DN Zoll Inch	DN metric ISO 4397	Q _{max}		Working Pressure		Bursting Pressure Connected		Female Body		Male Tip		Spillage	
				l/min	US GPM	bar	PSI	bar	PSI	bar	PSI	bar	PSI	ml	fl oz
HR-10	2	3/8"	10	50	13.21	610	8847	2450	35534	2450	35534	2600	37710	2	.0676
HR-12	3	1/2"	12,5	85	22.45	470	6817	1900	27557	2100	30458	1650	23931	3	.1014
HR-19	6	3/4"	19 (20)	120	31.70	310	4496	1250	18130	1500	21756	1250	18130	10	.3381
HR-25	8	1"	25	280	73.97	300	4351	1300	18855	1600	23206	1100	15954	16	.5410
HR-31	10	1 1/4"	31	460	121.52	300	4351	1300	18855	1300	18855	1200	17404	30	1.0144
HR-38	12	1 1/2"	38	700	184.92	270	3916	1100	15954	1500	21756	950	13779	54	1.8260

The indicated pressure ratings only apply to the coupling itself and depend on the connection type.

Flow Characteristics

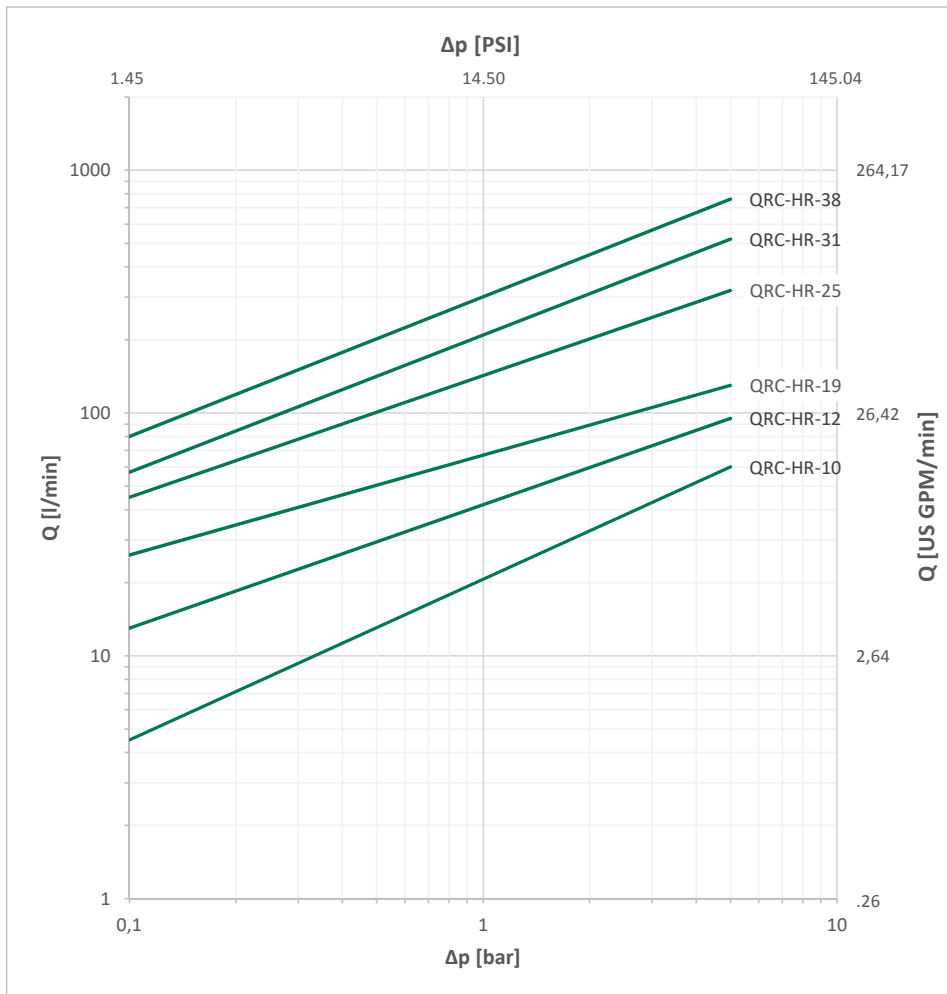

Please note: Unless otherwise stated, all flow characteristics have been determined with hydraulic oil with a kinematic viscosity of 28,8 - 35,2 mm²/s (28,8 - 35,2 cSt) and are only valid for components with non-reducing connections.



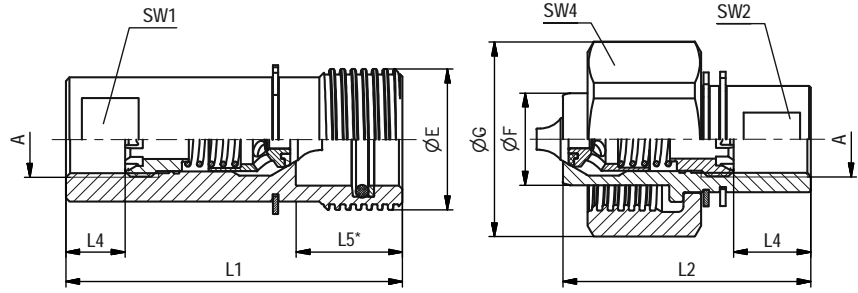

SW: Width across flats. All dimensions in mm (inch). Drawing similar Series HR-12.
* Insertion Female Body.

Series HR-10 • BG 2 • Nominal Size 10

Port A	Dimensions (mm/in)											Female Body		Weight (kg/lbs) ca. per 100	Male Tip		Weight (kg/lbs) ca. per 100
	ØE	ØF	ØG	L1	L2	L4 min	L5	SW1	SW2	SW4	Old Part Numbers	STAUFF Ordering Codes	Old Part Numbers		STAUFF Ordering Codes		
	Female Thread according to DIN 3852																
 G 3/8"	36	22	49	77	57	12	22	22	22	45	HR10-1-IGF06	31,80	HR10-2-IGF06	35,20			
	1.42	.87	1.93	3.03	2.24	.47	.87	.87	.87	1.77	QRC-HR-10-F-G06-BT-W66	70.11	QRC-HR-10-M-G06-B-W66	77.60			
	36	22	49	77	57	12	22	22	22	45	HR10-3MIGF06	37,10	HR10-4MIGF06	41			
	1.42	.87	1.93	3.03	2.24	.47	.87	.87	.87	1.77	QRC-HR-10-FD-G06-BT-W66-DM	81.79	QRC-HR-10-MD-G06-B-W66-DM	90.39			

Series HR-12 • BG 3 • Nominal Size 12,5

Port A	Dimensions (mm/in)											Female Body		Weight (kg/lbs) ca. per 100	Male Tip		Weight (kg/lbs) ca. per 100
	ØE	ØF	ØG	L1	L2	L4 min	L5	SW1	SW2	SW4	Old Part Numbers	STAUFF Ordering Codes	Old Part Numbers		STAUFF Ordering Codes		
	Female Thread according to DIN 3852																
 G 1/2"	40	26	55	95	70	14	30	26	26	50	HR12-1-IGF08	48,40	HR12-2-IGF08	48			
	1.57	1.02	2.16	3.74	2.76	.55	1.18	1.02	1.02	1.97	QRC-HR-12-F-G08-BT-W66	106.70	QRC-HR-12-M-G08-B-W66	105.82			
	40	26	55	95	70	14	30	26	26	50	HR12-3MIGF08	54	HR12-4MIGF08	56,60			
	1.57	1.02	2.16	3.74	2.76	.55	1.18	1.02	1.02	1.97	QRC-HR-12-FD-G08-BT-W66-DM	119.05	QRC-HR-12-MD-G08-B-W66-DM	124.78			

Series HR-19 • BG 6 • Nominal Size 19

Port A	Dimensions (mm/in)											Female Body		Weight (kg/lbs) ca. per 100	Male Tip		Weight (kg/lbs) ca. per 100
	ØE	ØF	ØG	L1	L2	L4 min	L5	SW1	SW2	SW4	Old Part Numbers	STAUFF Ordering Codes	Old Part Numbers		STAUFF Ordering Codes		
	Female Thread according to DIN 3852																
 G 3/4"	44,7	26	60	99	73	16	30	30	30	60	HR19-1-IGF12	66	HR19-2-IGF12	59,90			
	1.76	1.02	2.36	3.90	2.87	.63	1.18	1.18	1.18	2.36	QRC-HR-19-F-G12-BT-W66	145.51	QRC-HR-19-M-G12-B-W66	132.06			
	44,7	26	60	99	73	16	30	30	30	60	HR19-3MIGF12	72,80	HR19-4MIGF12	68			
	1.76	1.02	2.36	3.90	2.87	.63	1.18	1.18	1.18	2.36	QRC-HR-19-FD-G12-BT-W66-DM	160.50	QRC-HR-19-MD-G12-B-W66-DM	149.91			

Series HR-25 • BG 8 • Nominal Size 25

Port A	Dimensions (mm/in)											Female Body		Weight (kg/lbs) ca. per 100	Male Tip		Weight (kg/lbs) ca. per 100
	ØE	ØF	ØG	L1	L2	L4 min	L5	SW1	SW2	SW4	Old Part Numbers	STAUFF Ordering Codes	Old Part Numbers		STAUFF Ordering Codes		
	Female Thread according to DIN 3852																
 G 1"	58	36,8	77	106	81	18	30	40	40	77	HR25-1-IGF16	117,90	HR25-2-IGF16	114,7			
	2.28	1.45	3.02	4.17	3.19	.71	1.18	1.57	1.57	3.02	QRC-HR-25-F-G16-BT-W66	259.93	QRC-HR-25-M-G16-B-W66	252.87			
	58	36,8	77	106	81	18	30	40	40	77	HR25-3MIGF16	125,70	HR25-4MIGF16	125,80			
	2.28	1.45	3.02	4.17	3.19	.71	1.18	1.57	1.57	3.02	QRC-HR-25-FD-G16-BT-W66-DM	277.12	QRC-HR-25-MD-G16-B-W66-DM	277.34			

HR

Note: The connection of the two halves of a coupling is achieved depending on the type. It is important to observe the positive engagement of plug-type couplings and the secure tightening of screw-type couplings to the limit stop of the thread. Forced or improper separation will result in malfunction of the coupling.



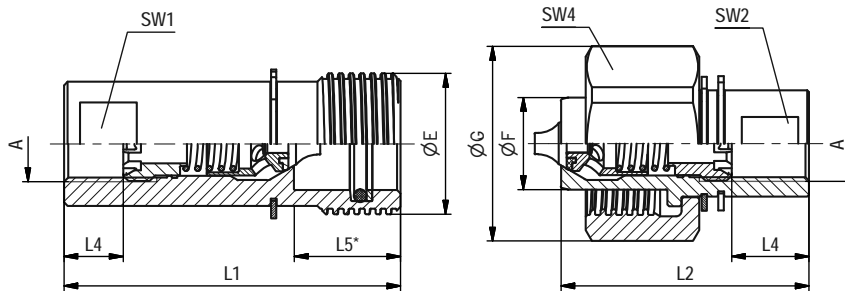

SW: Width across flats. All dimensions in mm (inch). Drawing similar Series HR-12.
* Insertion Female Body.

Series HR-31 • BG 10 • Nominal Size 31,5

Port A	Dimensions (mm/in)											Female Body	Weight	Male Tip	Weight
	ØE	ØF	ØG	L1	L2	L4 min	L5	SW1	SW2	SW4	Old Part Numbers	(^{kg} /lbs) ca.	Old Part Numbers	(^{kg} /lbs) ca.	
Female Thread according to DIN 3852											STAUFF Ordering Codes	per 100	STAUFF Ordering Codes	per 100	
	G 1 1/4"	66	47	88	118	88	20	35	48	48	88	HR31-1-IGF20	160,60	HR31-2-IGF20	180,30
		2.60	1.85	3.46	4.65	3.46	.79	1.38	1.89	1.89	3.46	QRC-HR-31-F-G20-BT-W66	354.06	QRC-HR-31-M-G20-B-W66	397.49
		66	47	88	118	88	20	35	48	48	88	HR31-3MIGF20	171,10	HR31-4MIGF20	192,80
		2.60	1.85	3.46	4.65	3.46	.79	1.38	1.89	1.89	3.46	QRC-HR-31-FD-G20-BT-W66-DM	377.21	QRC-HR-31-MD-G20-B-W66-DM	425.05

Series HR-38 • BG 12 • Nominal Size 38

Port A	Dimensions (mm/in)											Female Body	Weight	Male Tip	Weight
	ØE	ØF	ØG	L1	L2	L4 min	L5	SW1	SW2	SW4	Old Part Numbers	(^{kg} /lbs) ca.	Old Part Numbers	(^{kg} /lbs) ca.	
Female Thread according to DIN 3852											STAUFF Ordering Codes	per 100	STAUFF Ordering Codes	per 100	
	G 1 1/2"	75	57	93	121	90	22	35	55	55	93	HR38-1-IGF24	200,60	HR38-2-IGF24	218,40
		2.95	2.24	3.66	4.76	3.54	.87	1.38	2.16	2.16	3.66	QRC-HR-38-F-G24-BT-W66	442.25	QRC-HR-38-M-G24-B-W66	481.49
		75	57	93	121	90	22	35	55	55	93	HR38-3MIGF24	213,90	HR38-4MIGF24	233,10
		2.95	2.24	3.66	4.76	3.54	.87	1.38	2.16	2.16	3.66	QRC-HR-38-FD-G24-BT-W66-DM	471.57	QRC-HR-38-MD-G24-B-W66-DM	513.90

Note: The connection of the two halves of a coupling is achieved depending on the type. It is important to observe the positive engagement of plug-type couplings and the secure tightening of screw-type couplings to the limit stop of the thread. Forced or improper separation will result in malfunction of the coupling.

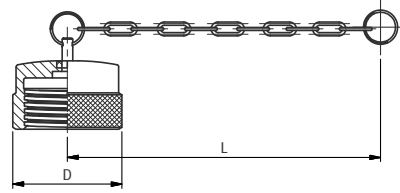
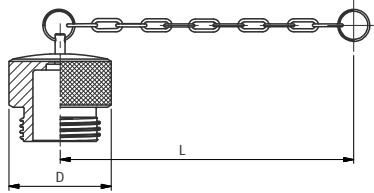

Series HR • Dust Protection

Dimensions (mm/in)			Material	Dust Plug for Male Tip	
D1	D2	L		Old Part Numbers	STAUFF Ordering Codes
48		200	Plastic (Colour: Black)	HR10-0-SW001	
1.89		7.87		QRC-HR-10-DM-CN-KI-BK	
51		200	Plastic (Colour: Black)	HR12-0-SW001	
2.01		7.87		QRC-HR-12-DM-CN-KI-BK	
57		200	Plastic (Colour: Black)	HR19-0-SW001	
2.24		7.87		QRC-HR-19-DM-CN-KI-BK	
68		200	Plastic (Colour: Black)	HR25-0-SW001	
2.68		7.87		QRC-HR-25-DM-CN-KI-BK	
76		265	Plastic (Colour: Black)	HR31-0-SW001	
2.99		10.43		QRC-HR-31-DM-CN-KI-BK	
86		265	Plastic (Colour: Black)	HR38-0-SW001	
3.39		10.43		QRC-HR-38-DM-CN-KI-BK	

Dimensions (mm/in)			Material	Dust Cap for Female Body	
D1	D2	L		Old Part Numbers	STAUFF Ordering Codes
48		200	Plastic (Colour: Black)	HR10-9-SW001	
1.89		7.87		QRC-HR-10-DF-CN-KI-BK	
51		200	Plastic (Colour: Black)	HR12-9-SW001	
2.01		7.87		QRC-HR-12-DF-CN-KI-BK	
57		200	Plastic (Colour: Black)	HR19-9-SW001	
2.24		7.87		QRC-HR-19-DF-CN-KI-BK	
68		200	Plastic (Colour: Black)	HR25-9-SW001	
2.68		7.87		QRC-HR-25-DF-CN-KI-BK	
76		265	Plastic (Colour: Black)	HR31-9-SW001	
2.99		10.43		QRC-HR-31-DF-CN-KI-BK	
85		265	Plastic (Colour: Black)	HR38-9-SW001	
3.35		10.43		QRC-HR-38-DF-CN-KI-BK	

In addition to the standard colours as stated above, plastic dust caps are also available in blue, green, yellow and black. Please use the old color codes BL, GN, GE and SW respectively instead of RT. Please use the STAUFF codes BU, GN, YE and BK respectively instead of RD.

Note: The connection of the two halves of a coupling is achieved depending on the type. It is important to observe the positive engagement of plug-type couplings and the secure tightening of screw-type couplings to the limit stop of the thread. Forced or improper separation will result in malfunction of the coupling.



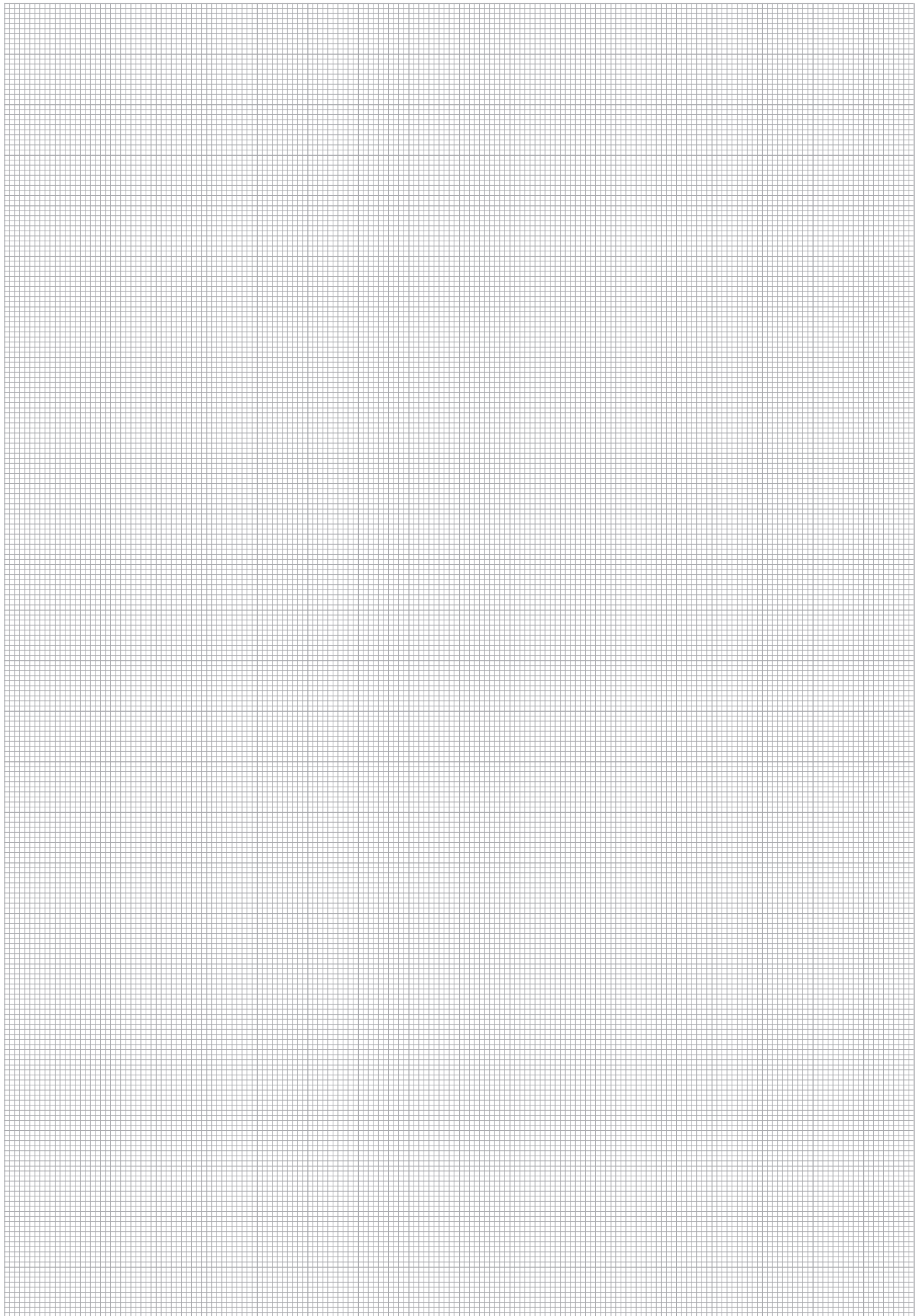

HR



Series HH • Carbon Steel

Series HH • Overview	154	Series HH-51 • BG 14 • Nominal Size 51	156
Series HH-10 • BG 2 • Nominal Size 10	155	Series HH • Dust Protection	157
Series HH-12 • BG 3 • Nominal Size 12,5	155		
Series HH-19 • BG 6 • Nominal Size 19	155		
Series HH-25 • BG 8 • Nominal Size 25	155		
Series HH-31 • BG 10 • Nominal Size 31,5	156		
Series HH-38 • BG 12 • Nominal Size 38	156		



HH



Series HH ▪ Carbon Steel

Material	Carbon Steel
Surface Finishing	Zinc-Nickel
Standard Seal Material(s)	NBR (Buna-N®) ²
Working Temperature	-25° C ... +100° C / -13° F ... +212° F
Valve Design	Poppet Valve
Connection	Screw
Disconnection	Screw
Connect Under Pressure	Male Tip and Female Body allowed
Application	Industrial Hydraulic, Rescue and Tensioning Hydraulics
ISO Interchange	-



²Alternative seal materials are available on request.

Technical Data

Series	BG	DN Zoll	DN metric ISO 4397	Q _{max}		Working Pressure		Bursting Pressure Connected		Female Body		Male Tip		Spillage	
				l/min	US GPM	bar	PSI	bar	PSI	bar	PSI	bar	PSI	ml	fl oz
HH-10	2	3/8"	10	18	4.75	650	9427	3000	43511	3000	43511	3000	43511	1,9	.0642
HH-12	3	1/2"	12,5	23	6.08	600	8702	2200	31908	2700	39160	2500	36259	2,7	.0913
HH-19	6	3/4"	19 (20)	45	11.89	500	7252	2100	30458	2600	37710	2400	34809	9,3	.3145
HH-25	8	1"	25	106	28.00	460	6672	2000	29007	2600	37710	2300	33359	16	.5410
HH-31	10	1 1/4"	31	189	49.93	360	5221	1500	21756	1500	21756	1500	21756	30	1.0144
HH-38	12	1 1/2"	38	300	79.25	360	5221	1500	21756	1500	21756	1200	17404	54	1.8260
HH-51	14	2"	51	757	199.98	210	3046	1050	15228	1300	21756	1300	18855	120	4.0577

The indicated pressure ratings only apply to the coupling itself and depend on the connection type.

Flow Characteristics

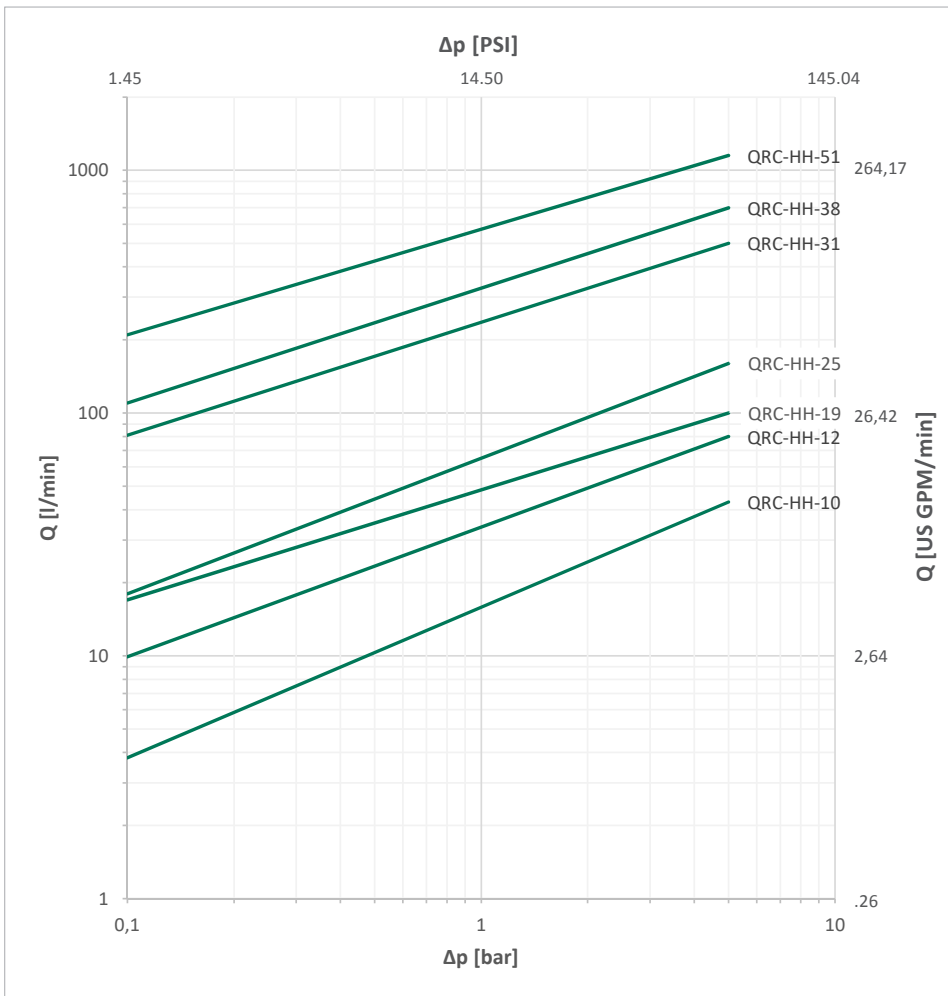

Please note: Unless otherwise stated, all flow characteristics have been determined with hydraulic oil with a kinematic viscosity of 28,8 - 35,2 mm²/s (28,8 - 35,2 cSt) and are only valid for components with non-reducing connections.



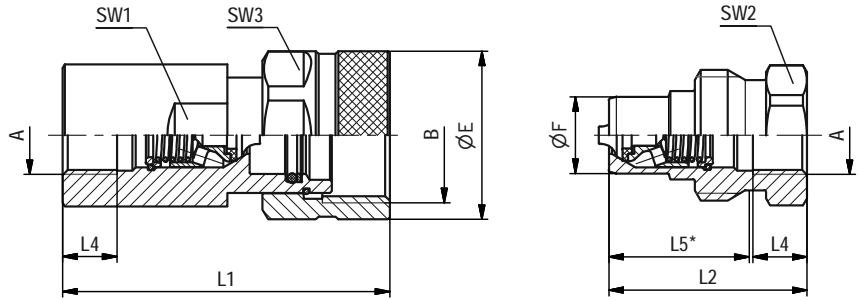

SW: Width across flats. All dimensions in mm (inch). Drawing similar Series HH-12.
* Insertion Male Tip.

Series HH-10 • BG 2 • Nominal Size 10

Port A	Dimensions (mm/in)											Female Body		Weight (^{kg} /lbs) ca. per 100	Male Tip		Weight (^{kg} /lbs) ca. per 100
	ØE	ØF	B	L1	L2	L4 min	L5	SW1	SW2	SW3	Old Part Numbers	STAUFF Ordering Codes	Old Part Numbers		STAUFF Ordering Codes		
											Female Thread according to DIN 3852 - ANSI B 1.20.3						
	G 3/8"	40	19	1 1/4" - 8 UN	76	48	12	34	30	32	36	HH10-1-IGF06	34,40	HH10-2-IGF06	15,50		
		1.57	.75		2.99	1.89	.47	1.34	1.18	1.26	1.42	QRC-HH-10-F-G06-BT-W3	75.84	QRC-HH-10-M-G06-B-W3	34.17		
	NPTF 3/8" -18	40	19	1 1/4" - 8 UN	76	48		34	30	32	36	HH10-1-INF06	34,60	HH10-2-INF06	15,70		
		1.57	.75		2.99	1.89		1.34	1.18	1.26	1.42	QRC-HH-10-F-NF06-BT-W3	76.28	QRC-HH-10-M-NF06-B-W3	34.61		

Series HH-12 • BG 3 • Nominal Size 12,5

Port A	Dimensions (mm/in)											Female Body		Weight (^{kg} /lbs) ca. per 100	Male Tip		Weight (^{kg} /lbs) ca. per 100
	ØE	ØF	B	L1	L2	L4 min	L5	SW1	SW2	SW3	Old Part Numbers	STAUFF Ordering Codes	Old Part Numbers		STAUFF Ordering Codes		
											Female Thread according to DIN 3852 - ANSI B 1.20.3						
	G 1/2"	45	20,5	1 3/8" - 8 UN	87	53	14	37,5	34	34	41	HH12-1-IGF08	57,60	HH12-2-IGF08	17,70		
		1.77	.81		3.43	2.09	.55	1.48	1.34	1.34	1.61	QRC-HH-12-F-G08-BT-W3	126.99	QRC-HH-12-M-G08-B-W3	39.02		
	NPTF 1/2" -14	45	20,5	1 3/8" - 8 UN	87	53		37,5	34	34	41	HH12-1-INF08	58,20	HH12-2-INF08	18		
		1.77	.81		3.43	2.09		1.48	1.34	1.34	1.61	QRC-HH-12-F-NF08-BT-W3	128.31	QRC-HH-12-M-NF08-B-W3	39.68		

Series HH-19 • BG 6 • Nominal Size 19

Port A	Dimensions (mm/in)											Female Body		Weight (^{kg} /lbs) ca. per 100	Male Tip		Weight (^{kg} /lbs) ca. per 100
	ØE	ØF	B	L1	L2	L4 min	L5	SW1	SW2	SW3	Old Part Numbers	STAUFF Ordering Codes	Old Part Numbers		STAUFF Ordering Codes		
											Female Thread according to DIN 3852 - ANSI B 1.20.3						
	G 3/4"	55	27,9	1 3/4" - 6 UN	106	63	16	48	41	46	50	HH19-1-IGF12	98,80	HH19-2-IGF12	36,40		
		2.16	1.1		4.17	2.48	.63	1.89	1.61	1.81	1.97	QRC-HH-19-F-G12-BT-W3	217.82	QRC-HH-19-M-G12-B-W3	80.25		
	NPTF 3/4" -14	55	27,9	1 3/4" - 6 UN	106	63		48	41	46	50	HH19-1-INF12	99,70	HH19-2-INF12	37,30		
		2.16	1.1		4.17	2.48		1.89	1.61	1.81	1.97	QRC-HH-19-F-NF12-BT-W3	219.80	QRC-HH-19-M-NF12-B-W3	82.23		

Series HH-25 • BG 8 • Nominal Size 25

Port A	Dimensions (mm/in)											Female Body		Weight (^{kg} /lbs) ca. per 100	Male Tip		Weight (^{kg} /lbs) ca. per 100
	ØE	ØF	B	L1	L2	L4 min	L5	SW1	SW2	SW3	Old Part Numbers	STAUFF Ordering Codes	Old Part Numbers		STAUFF Ordering Codes		
											Female Thread according to DIN 3852 - ANSI B 1.20.3						
	G 1"	60	31,2	M52x4	123	72	18	56	50	50	55	HH25-1-IGF16	140,30	HH25-2-IGF16	53,20		
		2.36	1.23		4.84	2.83	.71	2.2	1.97	1.97	2.16	QRC-HH-25-F-G16-BT-W3	309.31	QRC-HH-25-M-G16-B-W3	117.29		
	NPTF 1" -11 1/2	60	31,2	M52x4	123	72		56	50	50	55	HH25-1-INF16	148,10	HH25-2-INF16	54		
		2.36	1.23		4.84	2.83		2.2	1.97	1.97	2.16	QRC-HH-25-F-NF16-BT-W3	326.50	QRC-HH-25-M-NF16-B-W3	119.05		

HH

Note: The connection of the two halves of a coupling is achieved depending on the type. It is important to observe the positive engagement of plug-type couplings and the secure tightening of screw-type couplings to the limit stop of the thread. Forced or improper separation will result in malfunction of the coupling.



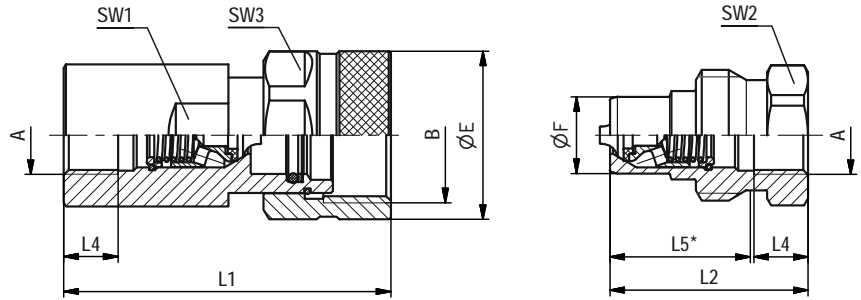

SW: Width across flats. All dimensions in mm (inch). Drawing similar Series HH-12.
* Insertion Male Tip.

Series HH-31 • BG 10 • Nominal Size 31,5

Port A	Dimensions (mm/in)		Female Body	Weight (kg/lbs) ca. per 100	Male Tip	Weight (kg/lbs) ca. per 100									
	ØE	ØF					B	L1	L2	L4 min	L5	SW1	SW2	SW3	Old Part Numbers
Female Thread according to DIN 3852 - ANSI B 1.20.3															
	G 1 1/4"	80	44	M68x6	153	86	20	72	65	65	75	HH31-1-IGF20	287	HH31-2-IGF20	105
		3.15	1.73		6.02	3.39	.79	2.83	2.56	2.56	2.95	QRC-HH-31-F-G20-BT-W3	632.73	QRC-HH-31-M-G20-B-W3	231.49
	NPTF 1 1/4" -11 1/2	80	44	M68x6	153	86		72	65	65	75	HH31-1-INF20	295	HH31-2-INF20	109.20
		3.15	1.73		6.02	3.39		2.83	2.56	2.56	2.95	QRC-HH-31-F-NF20-BT-W3	650.36	QRC-HH-31-M-NF20-B-W3	240.74

Series HH-38 • BG 12 • Nominal Size 38

Port A	Dimensions (mm/in)		Female Body	Weight (kg/lbs) ca. per 100	Male Tip	Weight (kg/lbs) ca. per 100									
	ØE	ØF					B	L1	L2	L4 min	L5	SW1	SW2	SW3	Old Part Numbers
Female Thread according to DIN 3852 - ANSI B 1.20.3															
	G 1 1/2"	98	53.4	M78x6	172	95	22	80	75	80	90	HH38-1-IGF24	444	HH38-2-IGF24	170
		3.86	2.10		6.77	3.74	.87	3.15	2.95	3.15	3.54	QRC-HH-38-F-G24-BT-W3	978.85	QRC-HH-38-M-G24-B-W3	374.79
	NPTF 1 1/2" -11 1/2	98	53.4	M78x6	172	95		80	75	80	90	HH38-1-INF24	447	HH38-2-INF24	172
		3.86	2.10		6.77	3.74		3.15	2.95	3.15	3.54	QRC-HH-38-F-NF24-BT-W3	985.47	QRC-HH-38-M-NF24-B-W3	379.20

Series HH-51 • BG 14 • Nominal Size 51

Port A	Dimensions (mm/in)		Female Body	Weight (kg/lbs) ca. per 100	Male Tip	Weight (kg/lbs) ca. per 100									
	ØE	ØF					B	L1	L2	L4 min	L5	SW1	SW2	SW3	Old Part Numbers
Female Thread according to DIN 3852 - ANSI B 1.20.3															
	G 2"	129	81.8	M115x8	205	118	24	96	100	110	125	HH51-1-IGF32	867	HH51-2-IGF32	493
		5.07	3.22		8.07	4.65	.94	3.78	3.93	4.33	4.92	QRC-HH-51-F-G32-BT-W3	1911.41	QRC-HH-51-M-G32-B-W3	1086.88
	NPTF 2" -11 1/2	129	81.8	M115x8	205	118		96	100	110	125	HH51-1-INF32	892	HH51-2-INF32	507
		5.07	3.22		8.07	4.65		3.78	3.93	4.33	4.92	QRC-HH-51-F-NF32-BT-W3	1966.52	QRC-HH-51-M-NF32-B-W3	1117.74

Note: The connection of the two halves of a coupling is achieved depending on the type. It is important to observe the positive engagement of plug-type couplings and the secure tightening of screw-type couplings to the limit stop of the thread. Forced or improper separation will result in malfunction of the coupling.

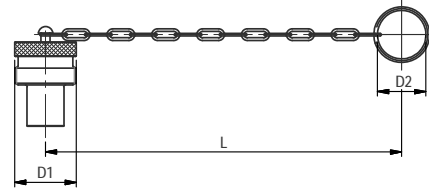
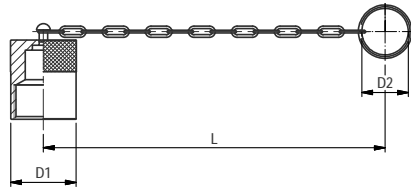

Series HH • Dust Protection

Dimensions (mm/in)			Material	Dust Cap for Male Tip	
D1	D2	L		Old Part Numbers	STAUFF Ordering Codes
34	30	240	Aluminium with chain	HH10-0-SI001	
1.34	1.18	9.45		QRC-HH-10-DM-30/CN-W89-SI	
38	30	240	Aluminium with chain	HH12-0-SI001	
1.50	1.18	9.45		QRC-HH-12-DM-30/CN-W89-SI	
48	41	290	Aluminium with chain	HH19-0-SI001	
1.89	1.61	11.42		QRC-HH-19-DM-41/CN-W89-SI	
58	48	300	Aluminium with chain	HH25-0-SI001	
2.28	1.89	11.81		QRC-HH-25-DM-48/CN-W89-SI	
81	48	400	Aluminium with chain	HH31-0-SI001	
3.19	1.89	15.75		QRC-HH-31-DM-48/CN-W89-SI	
85	46	260	Aluminium with chain	HH38-0-SI001	
3.35	1.81	10.24		QRC-HH-38-DM-46/CN-W89-SI	
100	46	300	Aluminium with chain	HH51-0-SI001	
3.94	1.81	11.81		QRC-HH-51-DM-46/CN-W89-SI	

Dimensions (mm/in)			Material	Dust Plug for Female Body	
D1	D2	L		Old Part Numbers	STAUFF Ordering Codes
34	30	240	Aluminium with chain	HH10-9-SI001	
1.34	1.18	9.45		QRC-HH-10-DF-30/CN-W89-SI	
34	30	240	Aluminium with chain	HH12-9-SI001	
1.34	1.18	9.45		QRC-HH-12-DF-30/CN-W89-SI	
53	48	300	Aluminium with chain	HH19-9-SI001	
2.09	1.89	11.81		QRC-HH-19-DF-48/CN-W89-SI	
53	41	290	Aluminium with chain	HH25-9-SI001	
2.09	1.61	11.42		QRC-HH-25-DF-41/CN-W89-SI	
71	48	400	Aluminium with chain	HH31-9-SI001	
2.80	1.89	15.75		QRC-HH-31-DF-48/CN-W89-SI	
98	46	210	Aluminium with chain	HH38-9-SI001	
3.86	1.81	8.27		QRC-HH-38-DF-46/CN-W89-SI	
115	46	270	Aluminium with chain	HH51-9-SI001	
4.53	1.81	10.63		QRC-HH-51-DF-46/CN-W89-SI	



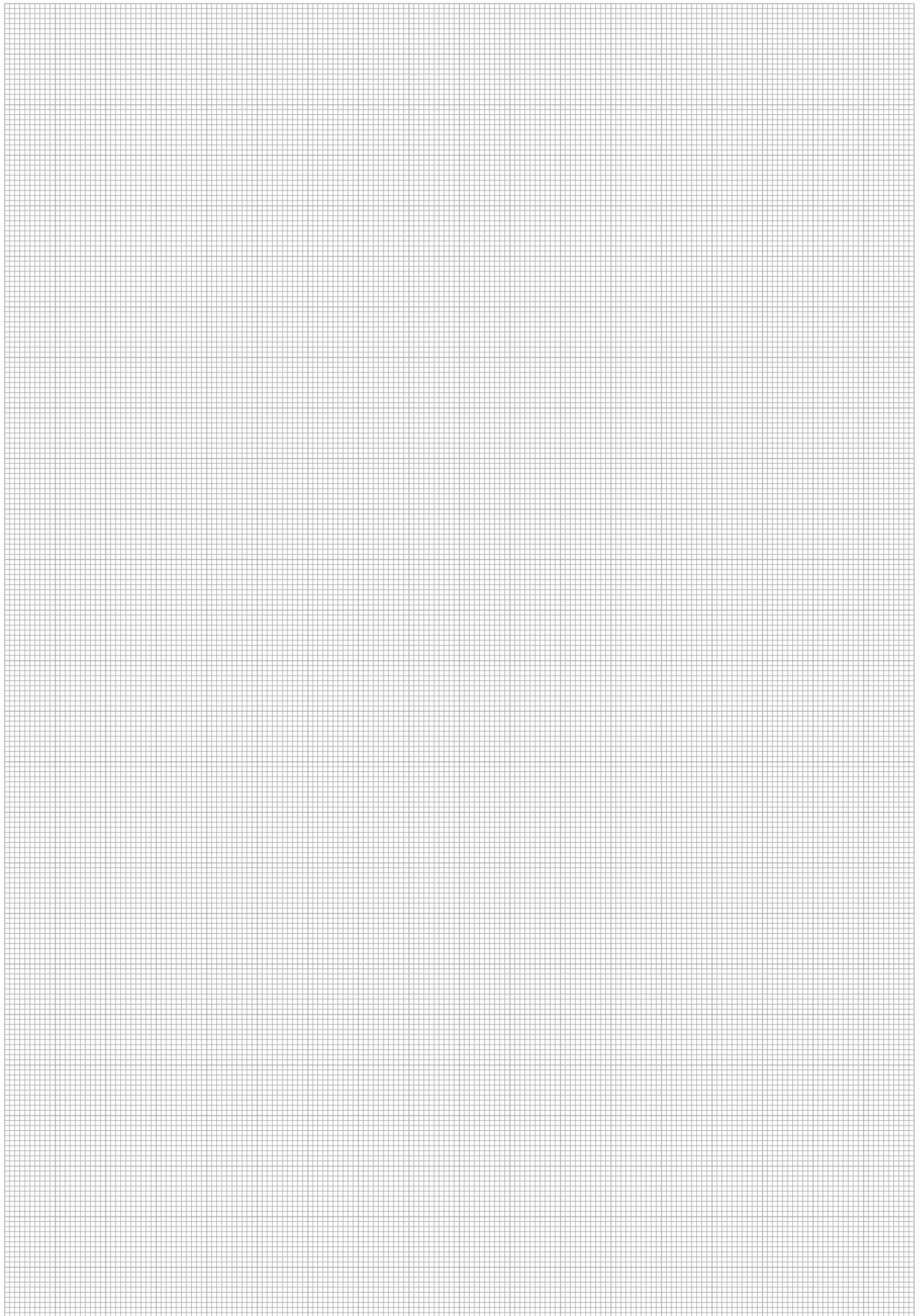

HH



Series HH • Stainless Steel

Series HH • Overview	160
Series HH-10 • BG 2 • Nominal Size 10	161
Series HH-12 • BG 3 • Nominal Size 12,5	161
Series HH-19 • BG 6 • Nominal Size 19	161
Series HH-25 • BG 8 • Nominal Size 25	161
Series HH-31 • BG 10 • Nominal Size 31,5	162
Series HH-38 • BG 12 • Nominal Size 38	162

Series HH-51 • BG 14 • Nominal Size 51	162
Series HH • Dust Protection	163



HH



Series HH ▪ Stainless Steel

Material	Stainless Steel V4A (AISI 316)
Surface Finishing	-
Standard Seal Material(s)	FKM (Viton®) ²
Working Temperature	-25° C ... +200° C / -13° F ... +392° F
Valve Design	Poppet Valve
Connection	Screw
Disconnection	Screw
Connect Under Pressure	Male Tip and Female Body allowed
Application	Industrial Hydraulic, Offshore, Rescue and Tensioning Hydraulics
ISO Interchange	-



²Alternative seal materials are available on request.

Technical Data

Series	BG	DN Zoll Inch	DN metric ISO 4397	Q _{max}		Working Pressure		Bursting Pressure Connected		Female Body		Male Tip		Spillage	
				l/min	US GPM	bar	PSI	bar	PSI	bar	PSI	bar	PSI	ml	fl oz
HH-10	2	3/8"	10	18	4.75	650	9427	2600	37710	2000	29008	2300	33359	1,9	.0642
HH-12	3	1/2"	12,5	23	6.08	600	8702	2500	36259	2700	39160	2100	30458	2,7	.0913
HH-19	6	3/4"	19 (20)	45	11.89	500	7252	2400	34809	1700	24656	2100	30458	9,3	.3145
HH-25	8	1"	25	106	28.00	460	6672	1500	21756	1900	27557	1600	23206	16	.5410
HH-31	10	1 1/4"	31	189	49.93	360	5221	1000	14504	1000	14504	1000	14504	30	1.0144
HH-38	12	1 1/2"	38	300	79.25	360	5221	900	13053	900	13053	900	13053	54	1.8260
HH-51	14	2"	51	757	199.98	210	3046	500	7252	500	7252	500	7252	120	4.0577

The indicated pressure ratings only apply to the coupling itself and depend on the connection type.

Flow Characteristics

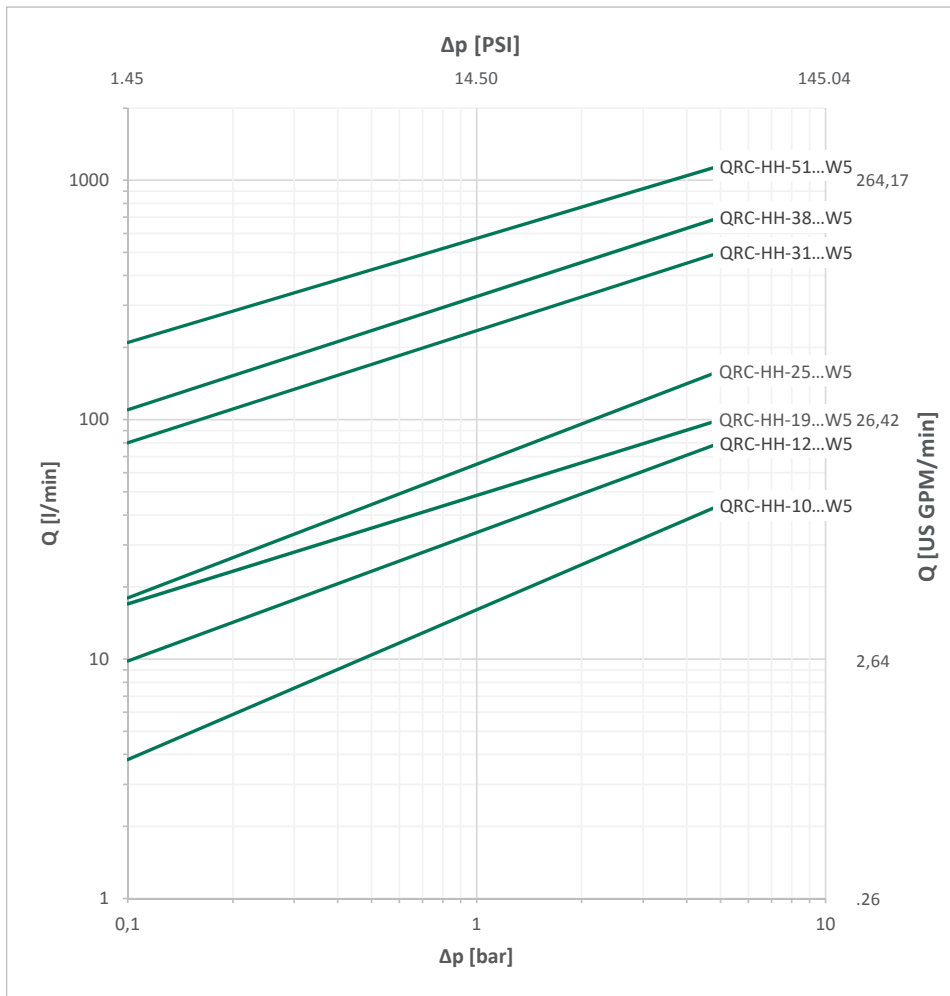

Please note: Unless otherwise stated, all flow characteristics have been determined with hydraulic oil with a kinematic viscosity of 28,8 - 35,2 mm²/s (28,8 - 35,2 cSt) and are only valid for components with non-reducing connections.



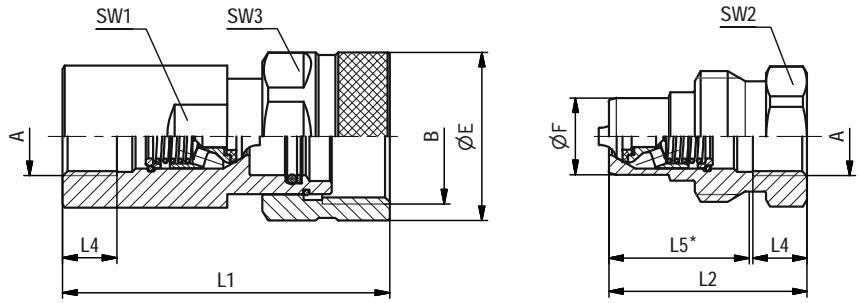

SW: Width across flats. All dimensions in mm (inch). Drawing similar Series HH-12.
* Insertion Male Tip.

Series HH-10 • BG 2 • Nominal Size 10

Port A	Dimensions (mm/in)										Female Body		Weight (^{kg} /lbs) ca. per 100	Male Tip		Weight (^{kg} /lbs) ca. per 100
	ØE	ØF	B	L1	L2	L4 min	L5	SW1	SW2	SW3	Old Part Numbers	STAUFF Ordering Codes		Old Part Numbers	STAUFF Ordering Codes	
Female Thread according to DIN 3852 - ANSI B 1.20.3																
	G 3/8"	40	19	1 1/4" - 8 UN	76	48	12	34	27	32	36	HH10-1-IGF06-VA	34,40	HH10-2-IGF06-VA	15,50	
		1.57	.75		2.99	1.89	.47	1.34	1.06	1.26	1.42	QRC-HH-10-F-G06-VT-W5	75.84	QRC-HH-10-M-G06-V-W5	34.17	
	NPTF 3/8" -18	40	19	1 1/4" - 8 UN	76	48		34	27	32	36	HH10-1-INF06-VA	34,60	HH10-2-INF06-VA	15,70	
		1.57	.75		2.99	1.89		1.34	1.06	1.26	1.42	QRC-HH-10-F-NF06-VT-W5	76.28	QRC-HH-10-M-NF06-V-W5	34.61	

Series HH-12 • BG 3 • Nominal Size 12,5

Port A	Dimensions (mm/in)										Female Body		Weight (^{kg} /lbs) ca. per 100	Male Tip		Weight (^{kg} /lbs) ca. per 100
	ØE	ØF	B	L1	L2	L4 min	L5	SW1	SW2	SW3	Old Part Numbers	STAUFF Ordering Codes		Old Part Numbers	STAUFF Ordering Codes	
Female Thread according to DIN 3852 - ANSI B 1.20.3																
	G 1/2"	45	20,5	1 3/8" - 8 UN	87	53	14	37,5	34	34	41	HH12-1-IGF08-VA	57,60	HH12-2-IGF08-VA	17,70	
		1.77	.81		3.43	2.09	.55	1.48	1.34	1.34	1.61	QRC-HH-12-F-G08-VT-W5	126.99	QRC-HH-12-M-G08-V-W5	39.02	
	NPTF 1/2" -14	45	20,5	1 3/8" - 8 UN	87	53		37,5	34	34	41	HH12-1-INF08-VA	58,20	HH12-2-INF08-VA	18	
		1.77	.81		3.43	2.09		1.48	1.34	1.34	1.61	QRC-HH-12-F-NF08-VT-W5	128.31	QRC-HH-12-M-NF08-V-W5	39.68	

Series HH-19 • BG 6 • Nominal Size 19

Port A	Dimensions (mm/in)										Female Body		Weight (^{kg} /lbs) ca. per 100	Male Tip		Weight (^{kg} /lbs) ca. per 100
	ØE	ØF	B	L1	L2	L4 min	L5	SW1	SW2	SW3	Old Part Numbers	STAUFF Ordering Codes		Old Part Numbers	STAUFF Ordering Codes	
Female Thread according to DIN 3852 - ANSI B 1.20.3																
	G 3/4"	55	27,9	1 3/4" - 6 UN	106	63	16	48	41	46	50	HH19-1-IGF12-VA	98,80	HH19-2-IGF12-VA	36,40	
		2.16	1.10		4.17	2.48	.63	1.89	1.61	1.81	1.97	QRC-HH-19-F-G12-VT-W5	217.82	QRC-HH-19-M-G12-V-W5	80.25	
	NPTF 3/4" -14	55	27,9	1 3/4" - 6 UN	106	63		48	41	46	50	HH19-1-INF12-VA	99,70	HH19-2-INF12-VA	37,30	
		2.16	1.10		4.17	2.48		1.89	1.61	1.81	1.97	QRC-HH-19-F-NF12-VT-W5	219.80	QRC-HH-19-M-NF12-V-W5	82.23	

Series HH-25 • BG 8 • Nominal Size 25

Port A	Dimensions (mm/in)										Female Body		Weight (^{kg} /lbs) ca. per 100	Male Tip		Weight (^{kg} /lbs) ca. per 100
	ØE	ØF	B	L1	L2	L4 min	L5	SW1	SW2	SW3	Old Part Numbers	STAUFF Ordering Codes		Old Part Numbers	STAUFF Ordering Codes	
Female Thread according to DIN 3852 - ANSI B 1.20.3																
	G 1"	60	31,2	M52x4	123	72	18	56	50	50	55	HH25-1-IGF16-VA	146,50	HH25-2-IGF16-VA	52,40	
		2.36	1.23		4.84	2.83	.71	2.20	1.97	1.97	2.16	QRC-HH-25-F-G16-VT-W5	322.98	QRC-HH-25-M-G16-V-W5	115.52	
	NPTF 1" -11	60	31,2	M52x4	123	72		56	50	50	55	HH25-1-INF16-VA	148,10	HH25-2-INF16-VA	54	
	1/2	2.36	1.23		4.84	2.83		2.20	1.97	1.97	2.16	QRC-HH-25-F-NF16-VT-W5	326.50	QRC-HH-25-M-NF16-V-W5	119.05	

HH

Note: The connection of the two halves of a coupling is achieved depending on the type. It is important to observe the positive engagement of plug-type couplings and the secure tightening of screw-type couplings to the limit stop of the thread. Forced or improper separation will result in malfunction of the coupling.



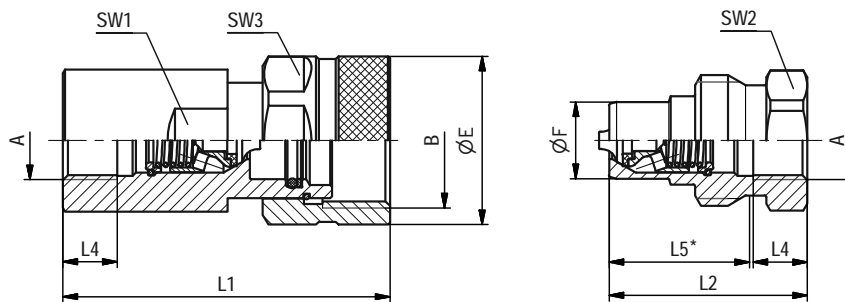

SW: Width across flats. All dimensions in mm (inch). Drawing similar Series HH-12.
* Insertion Male Tip.

Series HH-31 • BG 10 • Nominal Size 31,5

	Port A	Dimensions (mm/in)										Female Body		Weight (^{kg} /lbs) ca. per 100	Male Tip		Weight (^{kg} /lbs) ca. per 100
		ØE	ØF	B	L1	L2	L4 min	L5	SW1	SW2	SW3	Old Part Numbers	Old Part Numbers		STAUFF Ordering Codes	STAUFF Ordering Codes	
												STAUFF Ordering Codes	STAUFF Ordering Codes		STAUFF Ordering Codes	STAUFF Ordering Codes	
Female Thread according to DIN 3852 - ANSI B 1.20.3																	
	G 1 1/4"	80	44	M68x6	153	86	20	72	65	65	75	HH31-1-IGF20-VA	293,30	HH31-2-IGF20-VA	107,40		
		3.15	1.73		6.02	3.39	.79	2.83	2.56	2.56	2.95	QRC-HH-31-F-G20-VT-W5	646.62	QRC-HH-31-M-G20-V-W5	236.78		
	NPTF 1 1/4"	80	44	M68x6	153	86		72	65	65	75	HH31-1-INF20-VA	295	HH31-2-INF20-VA	109,20		
	-11 1/2	3.15	1.73		6.02	3.39		2.83	2.56	2.56	2.95	QRC-HH-31-F-NF20-VT-W5	650.36	QRC-HH-31-M-NF20-V-W5	240.74		

Series HH-38 • BG 12 • Nominal Size 38

	Port A	Dimensions (mm/in)										Female Body		Weight (^{kg} /lbs) ca. per 100	Male Tip		Weight (^{kg} /lbs) ca. per 100
		ØE	ØF	B	L1	L2	L4 min	L5	SW1	SW2	SW3	Old Part Numbers	Old Part Numbers		STAUFF Ordering Codes	STAUFF Ordering Codes	
												STAUFF Ordering Codes	STAUFF Ordering Codes		STAUFF Ordering Codes	STAUFF Ordering Codes	
Female Thread according to DIN 3852 - ANSI B 1.20.3																	
	G 1 1/2"	98	53,4	M78x6	172	95	22	80	75	80	90	HH38-1-IGF24-VA	455	HH38-2-IGF24-VA	173,40		
		3.86	2.10		6.77	3.74	.87	3.15	2.95	3.15	3.54	QRC-HH-38-F-G24-VT-W5	1003.10	QRC-HH-38-M-G24-V-W5	382.28		
	NPTF 1 1/2"	98	53,4	M78x6	172	95		80	75	80	90	HH38-1-INF24-VA	457	HH38-2-INF24-VA	173		
	-11 1/2	3.86	2.10		6.77	3.74		3.15	2.95	3.15	3.54	QRC-HH-38-F-NF24-VT-W5	1007.51	QRC-HH-38-M-NF24-V-W5	381.40		

Series HH-51 • BG 14 • Nominal Size 51

	Port A	Dimensions (mm/in)										Female Body		Weight (^{kg} /lbs) ca. per 100	Male Tip		Weight (^{kg} /lbs) ca. per 100
		ØE	ØF	B	L1	L2	L4 min	L5	SW1	SW2	SW3	Old Part Numbers	Old Part Numbers		STAUFF Ordering Codes	STAUFF Ordering Codes	
												STAUFF Ordering Codes	STAUFF Ordering Codes		STAUFF Ordering Codes	STAUFF Ordering Codes	
Female Thread according to DIN 3852 - ANSI B 1.20.3																	
	G 2"	129	81,8	M115x8	205	118	24	96	100	110	125	HH51-1-IGF32-VA	888	HH51-2-IGF32-VA	503		
		5.07	3.22		8.07	4.65	.94	3.78	3.93	4.33	4.92	QRC-HH-51-F-G32-VT-W5	1957.71	QRC-HH-51-M-G32-V-W5	1108.93		
	NPTF 2" -11	129	81,8	M115x8	205	118		96	100	110	125	HH51-1-INF32-VA	892	HH51-2-INF32-VA	507		
	1/2	5.07	3.22		8.07	4.65		3.78	3.93	4.33	4.92	QRC-HH-51-F-NF32-VT-W5	1966.52	QRC-HH-51-M-NF32-V-W5	1117.74		

Note: The connection of the two halves of a coupling is achieved depending on the type. It is important to observe the positive engagement of plug-type couplings and the secure tightening of screw-type couplings to the limit stop of the thread. Forced or improper separation will result in malfunction of the coupling.

HH

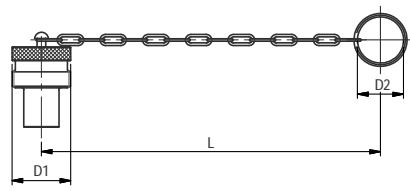
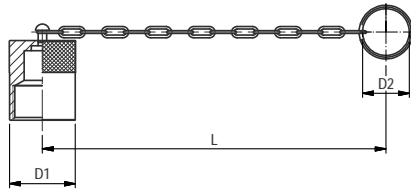

Series HH • Dust Protection

Dimensions (mm/in)			Material	Dust Cap for Male Tip	
D1	D2	L		Old Part Numbers	STAUFF Ordering Codes
34	30	240	Aluminium with chain	HH10-0-SI001	
1.34	1.18	9.45		QRC-HH-10-DM-30/CN-W89-SI	
38	30	240	Aluminium with chain	HH12-0-SI001	
1.50	1.18	9.45		QRC-HH-12-DM-30/CN-W89-SI	
48	41	290	Aluminium with chain	HH19-0-SI001	
1.89	1.61	11.42		QRC-HH-19-DM-41/CN-W89-SI	
58	48	300	Aluminium with chain	HH25-0-SI001	
2.28	1.89	11.81		QRC-HH-25-DM-48/CN-W89-SI	
81	48	400	Aluminium with chain	HH31-0-SI001	
3.19	1.89	15.75		QRC-HH-31-DM-48/CN-W89-SI	
85	46	260	Aluminium with chain	HH38-0-SI001	
3.35	1.81	10.24		QRC-HH-38-DM-46/CN-W89-SI	
100	46	300	Aluminium with chain	HH51-0-SI001	
3.94	1.81	11.81		QRC-HH-51-DM-46/CN-W89-SI	

Dimensions (mm/in)			Material	Dust Plug for Female Body	
D1	D2	L		Old Part Numbers	STAUFF Ordering Codes
34	30	240	Aluminium with chain	HH10-9-SI001	
1.34	1.18	9.45		QRC-HH-10-DF-30/CN-W89-SI	
34	30	240	Aluminium with chain	HH12-9-SI001	
1.34	1.18	9.45		QRC-HH-12-DF-30/CN-W89-SI	
53	48	300	Aluminium with chain	HH19-9-SI001	
2.09	1.89	11.81		QRC-HH-19-DF-48/CN-W89-SI	
53	41	290	Aluminium with chain	HH25-9-SI001	
2.09	1.61	11.42		QRC-HH-25-DF-41/CN-W89-SI	
71	48	400	Aluminium with chain	HH31-9-SI001	
2.80	1.89	15.75		QRC-HH-31-DF-48/CN-W89-SI	
98	46	210	Aluminium with chain	HH38-9-SI001	
3.86	1.81	8.27		QRC-HH-38-DF-46/CN-W89-SI	
115	46	270	Aluminium with chain	HH51-9-SI001	
4.53	1.81	10.63		QRC-HH-51-DF-46/CN-W89-SI	



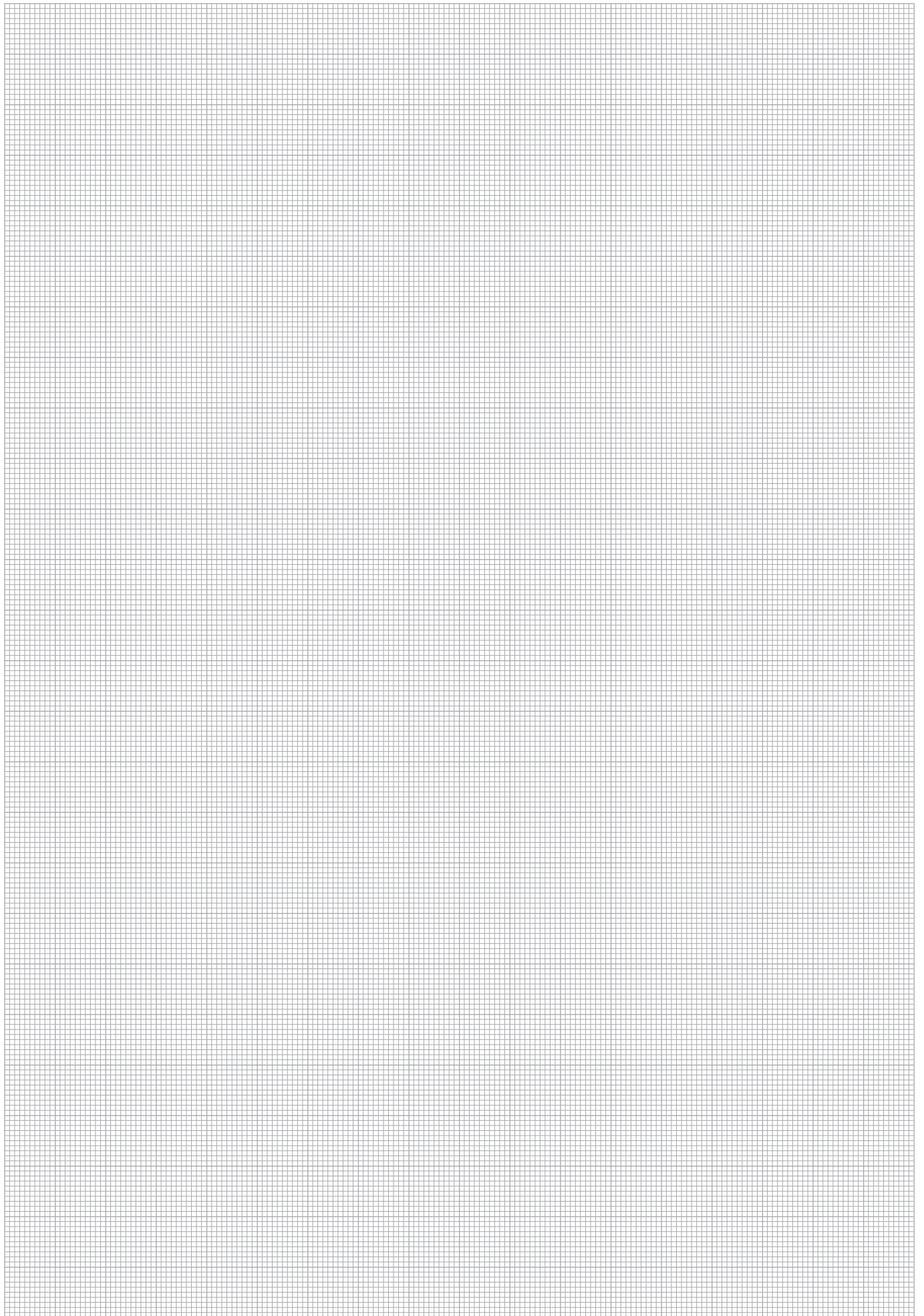

HH



Series HI - Carbon Steel

Series HI - Overview	166
Series HI-06 - BG 1 - Nominal Size 6,3	167
Series HI-10 - BG 2 - Nominal Size 10	167



HI



Series HI (HIB) • Carbon Steel

Material	Carbon Steel
Surface Finishing	Zinc-Nickel
Standard Seal Material(s)	NBR (Buna-N®), PU ²
Working Temperature	-25° C ... +100° C / -13° F ... +212° F
Valve Design	Poppet Valve (HI), Ball Valve (HIB) (optional)
Connection	Screw
Disconnection	Screw
Connect Under Pressure	not allowed
Application	Industrial Hydraulic, Rescue and Tensioning Hydraulics
ISO Interchange	ISO 14540



²Alternative seal materials are available on request.

Technical Data

Series	BG	DN Zoll Inch	DN metric ISO 4397	Q _{max}		Working Pressure		Bursting Pressure Connected		Female Body		Male Tip		Spillage	
				l/min	US GPM	bar	PSI	bar	PSI	bar	PSI	bar	PSI	ml	fl oz
HI-06	1	1/4"	6,3	10	2.64	720	10443	2160	31328	2160	31328	2160	31328	0,5	.0176
HI-10	2	3/8"	10	20	5.28	720	10443	2160	31328	2160	31328	2160	31328	1	.0352
HIB-06	1	1/4"	6,3	10	2.64	720	10443	2160	31328	1440	20885	1440	20885	0,5	.0176
HIB-10	2	3/8"	10	20	5.28	720	10443	2160	31328	1440	20885	1440	20885	1	.0352

The indicated pressure ratings only apply to the coupling itself and depend on the connection type.

Flow Characteristics

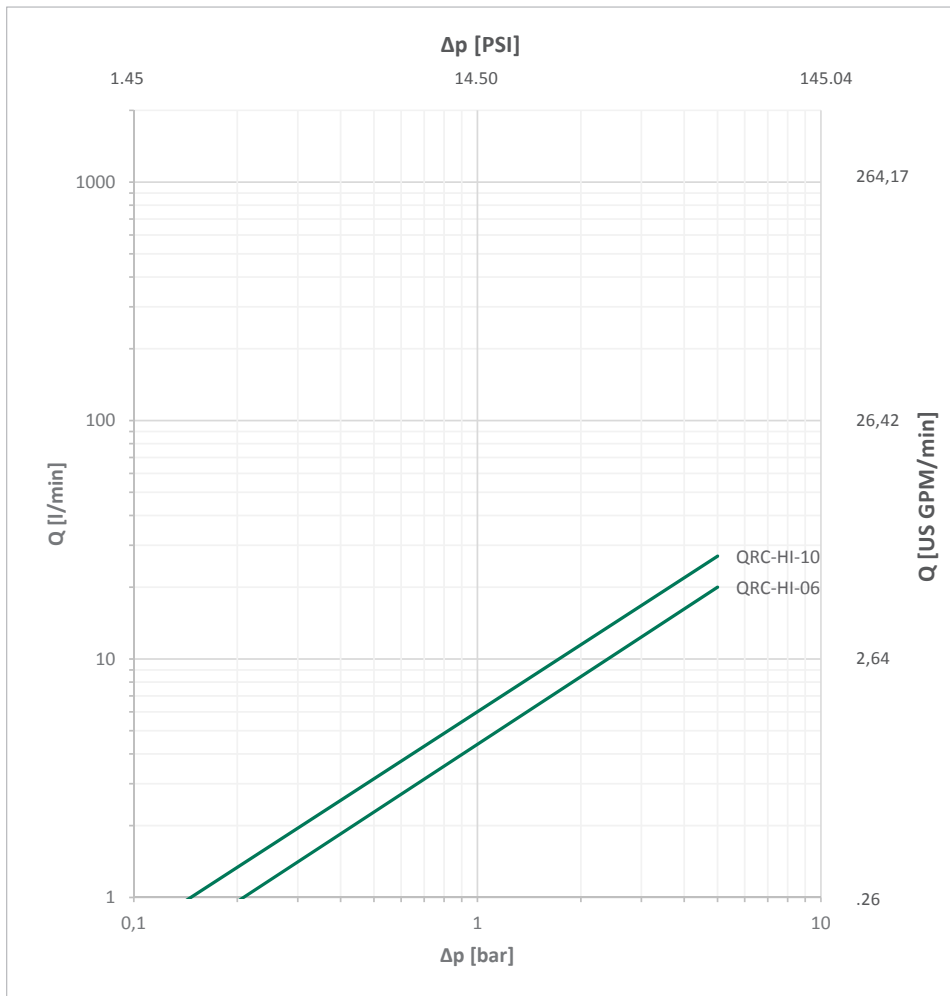



Please note: Unless otherwise stated, all flow characteristics have been determined with hydraulic oil with a kinematic viscosity of 28,8 - 35,2 mm²/s (28,8 - 35,2 cSt) and are only valid for components with non-reducing connections.

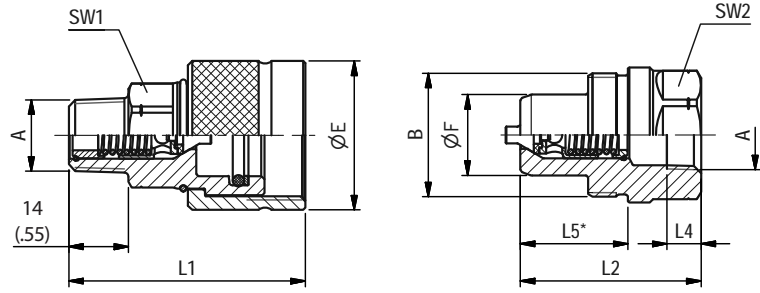

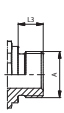
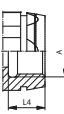

SW: Width across flats. All dimensions in mm (inch). Drawing similar Series HI-10.
* Insertion Male Tip.

Series HI-06 • BG 1 • Nominal Size 6,3

Port A	Dimensions (mm/in)										Female Body		Weight (^{kg} /lbs) ca. per 100	Male Tip		Weight (^{kg} /lbs) ca. per 100
	ØE	ØF	B	L1	L2	L4 min	L5	SW1	SW2	Old Part Numbers	STAUFF Ordering Codes	Old Part Numbers		STAUFF Ordering Codes		
Male Thread according to ANSI B 1.20.3																
 NPTF 1/4" -18	30	15,9	1" - 18 UNS	51,8			11,1	22	19	HI06-1-ANF04	13,10					
	1.18	.63		2.04			.44	.87	.75	QRC-HI-06-F-NF04M-S1-W3	28.88					
Female Thread according to DIN 3852 - ANSI B 1.20.3																
 G 1/4"	30	15,9	1" - 18 UNS	51,3	40,4	12	11,1	22	19	HI06-1-IGF04	14,90	HI06-2-IGF04	9			
	1.18	.63		2.02	1.59	.47	.44	.87	.75	QRC-HI-06-F-G04-BP-W3	32.85	QRC-HI-06-M-G04-BP-W3	19.84			
 NPTF 1/4" -18	30	15,9	1" - 18 UNS	51,3	40,5		11,1	22	19	HI06-1-INF04	15	HI06-2-INF04	9,10			
	1.18	.63		2.02	1.59		.44	.87	.75	QRC-HI-06-F-NF04-BP-W3	33.07	QRC-HI-06-M-NF04-BP-W3	20.06			

Series HI-10 • BG 2 • Nominal Size 10

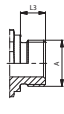
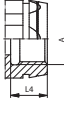
Port A	Dimensions (mm/in)										Female Body		Weight (^{kg} /lbs) ca. per 100	Male Tip		Weight (^{kg} /lbs) ca. per 100
	ØE	ØF	B	L1	L2	L4 min	L5	SW1	SW2	Old Part Numbers	STAUFF Ordering Codes	Old Part Numbers		STAUFF Ordering Codes		
Male Thread according to ANSI B 1.20.3																
 NPTF 3/8" -18	35	19	1" 3/16-16UN	56			25,3	24	32	HI10-1-ANF06	16,50					
	1.38	.75		2.19			.99	.94	1.26	QRC-HI-10-F-NF06M-S1-W3	36.38					
Female Thread according to ANSI B 1.20.3																
 NPTF 3/8" -18	35	19	1" 3/16-16UN	42,5			25,3	24	32			HI10-2-INF06	13,80			
	1.38	.75		1.67			.99	.94	1.26			QRC-HI-10-M-NF06-BP-W3	30.40			

In addition to the version with poppet valve is a version with ball valve available.
Please use for these version the code HIB instead of HI.

HI

Note: The connection of the two halves of a coupling is achieved depending on the type. It is important to observe the positive engagement of plug-type couplings and the secure tightening of screw-type couplings to the limit stop of the thread. Forced or improper separation will result in malfunction of the coupling.



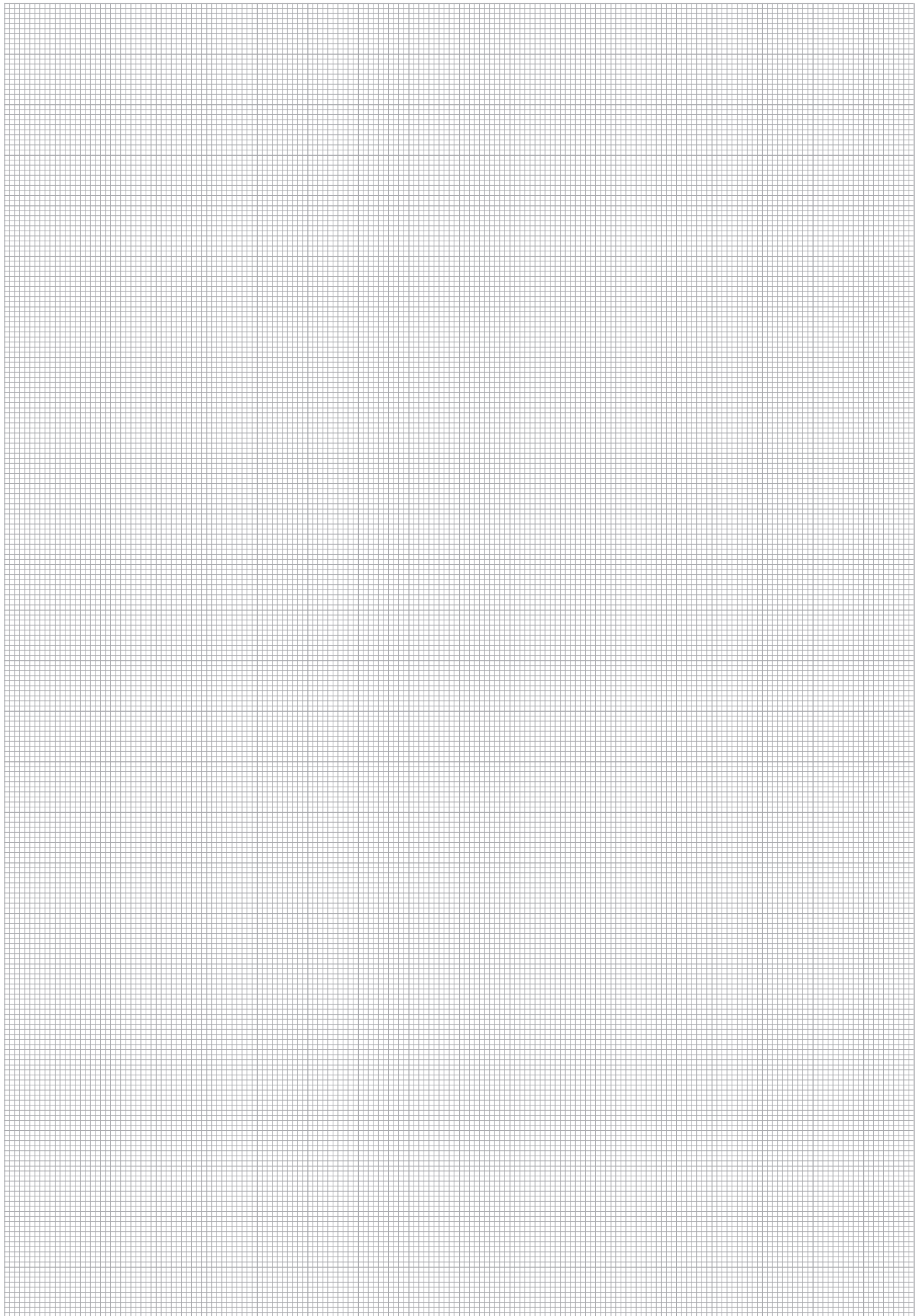

HI



Series HT - Carbon Steel

Series HT - Overview	170
Series HT-19 - BG 6 - Nominal Size 19	171
Series HT-25 - BG 8 - Nominal Size 25	171
Series HT - Dust Protection	171

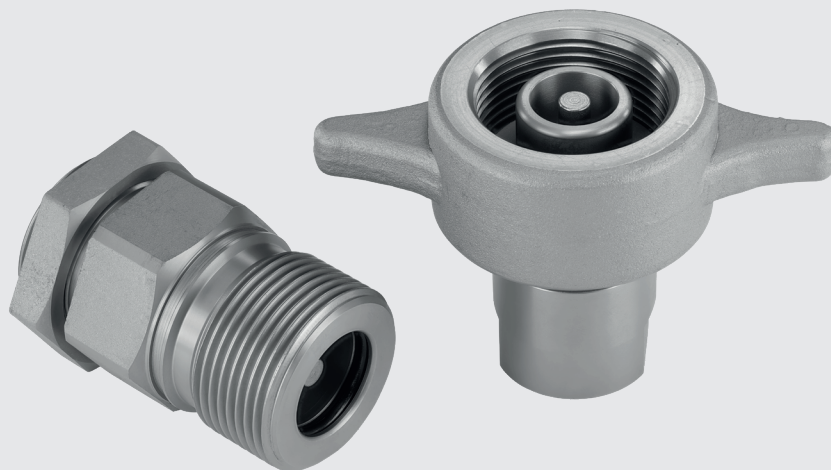
**HT**

Series HT • Carbon Steel

Material	Carbon Steel
Surface Finishing	Zinc-Nickel
Standard Seal Material(s)	NBR (Buna-N®) ²
Working Temperature	-25° C ... +100° C / -13° F ... +212° F
Valve Design	Poppet Valve
Connection	Screw
Disconnection	Screw
Connect Under Pressure	not allowed
Application	Industrial Hydraulic
ISO Interchange	-



Male Tip Female Body

²Alternative seal materials are available on request.

Technical Data

Series	BG	DN Zoll	DN metric ISO 4397	Q _{max}		Working Pressure		Bursting Pressure Connected		Female Body		Male Tip		Spillage	
				l/min	US GPM	bar	PSI	bar	PSI	bar	PSI	bar	PSI	ml	fl oz
HT-19	6	3/4"	19 (20)	240	63.40	350	5076	1300	18855	1000	14504	1000	14504	10	.3381
HT-25	8	1"	25	320	84.53	300	4351	1000	14504	1000	14504	1000	14504	15	.5072

The indicated pressure ratings only apply to the coupling itself and depend on the connection type.

Flow Characteristics

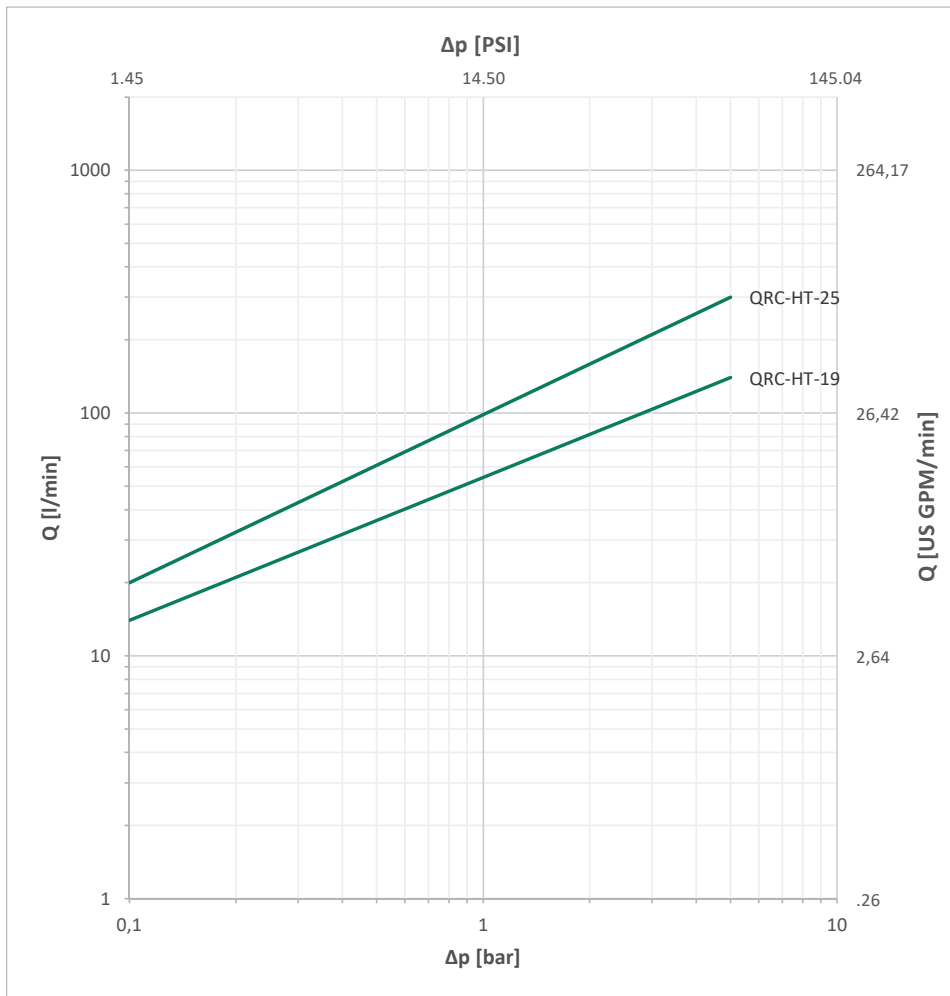

Please note: Unless otherwise stated, all flow characteristics have been determined with hydraulic oil with a kinematic viscosity of 28,8 - 35,2 mm²/s (28,8 - 35,2 cSt) and are only valid for components with non-reducing connections.

HT



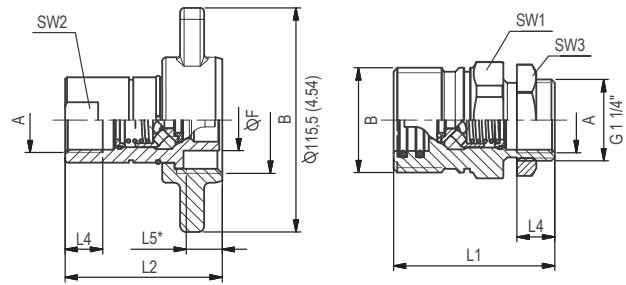

SW: Width across flats. All dimensions in mm (inch). Drawing similar Series HT-25.
* Insertion Male Tip.

Series HT-19 • BG 6 • Nominal Size 19

Port A	Dimensions (mm/in)	Female Body									Weight (^{kg} /lbs) ca. per 100	Male Tip		Weight (^{kg} /lbs) ca. per 100
		ØB	ØF	L1	L2	L4 min	L5	SW1	SW2	SW3		Old Part Numbers	Old Part Numbers	
Female Thread according to DIN 3852														
	G 3/4"	1 3/4" - 12 UN	25,2	78	80	16	25	46	33	50	HT19-1-IGF12	75,50	HT19-2-IGF12	70,40
			.99	3.07	3.15	.63	.98	1.81	1.30	1.97	QRC-HT-19-F-G12-B-W3	166.45	QRC-HT-19-M-G12-B-W3	155.21

Series HT-25 • BG 8 • Nominal Size 25

Port A	Dimensions (mm/in)	Female Body									Weight (^{kg} /lbs) ca. per 100	Male Tip		Weight (^{kg} /lbs) ca. per 100
		ØB	ØF	L1	L2	L4 min	L5	SW1	SW2	SW3		Old Part Numbers	Old Part Numbers	
Female Thread according to DIN 3852														
	G 1"	UNS 2 1/8"	31,75	81,5	81,5	18	18,5	55	40	50	HT25-1-IGF16	87,40	HT25-2-IGF16	91,50
			1.25	3.21	3.21	.71	.73	2.16	1.57	1.97	QRC-HT-25-F-G16-B-W3	192.68	QRC-HT-25-M-G16-B-W3	201.72

Series HT • Dust Protection

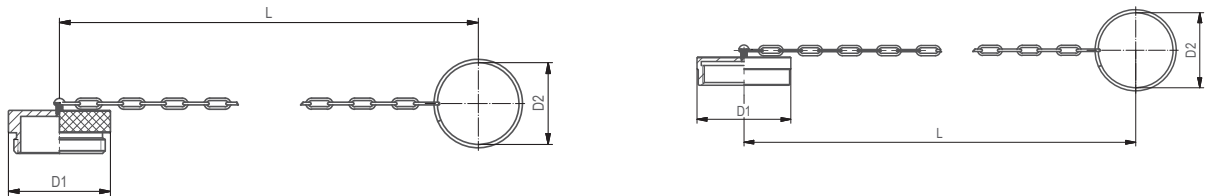

Dimensions (mm/in)			Material	Dust Plug for Female Body	
D1	D2	L		Old Part Numbers	STAUFF Ordering Codes
49,5	49	270	Carbon Steel with chain	HT19-0-ST001	QRC-HT-19-DF-49/CN-W3
1.95	1.93	10.63			
59,5	49	270	Carbon Steel with chain	HT25-0-ST001	QRC-HT-25-DF-49/CN-W3
2.34	1.93	10.63			

Dimensions (mm/in)			Material	Dust Cap for Male Tip	
D1	D2	L		Old Part Numbers	STAUFF Ordering Codes
49	41	270	Carbon Steel with chain	HT19-9-ST001	QRC-HT-19-DM-41/CN-W3
1.93	1.61	10.63			
59,5	49	270	Carbon Steel with chain	HT25-9-ST001	QRC-HT-25-DM-49/CN-W3
2.34	1.93	10.63			

Note: The connection of the two halves of a coupling is achieved depending on the type. It is important to observe the positive engagement of plug-type couplings and the secure tightening of screw-type couplings to the limit stop of the thread. Forced or improper separation will result in malfunction of the coupling.



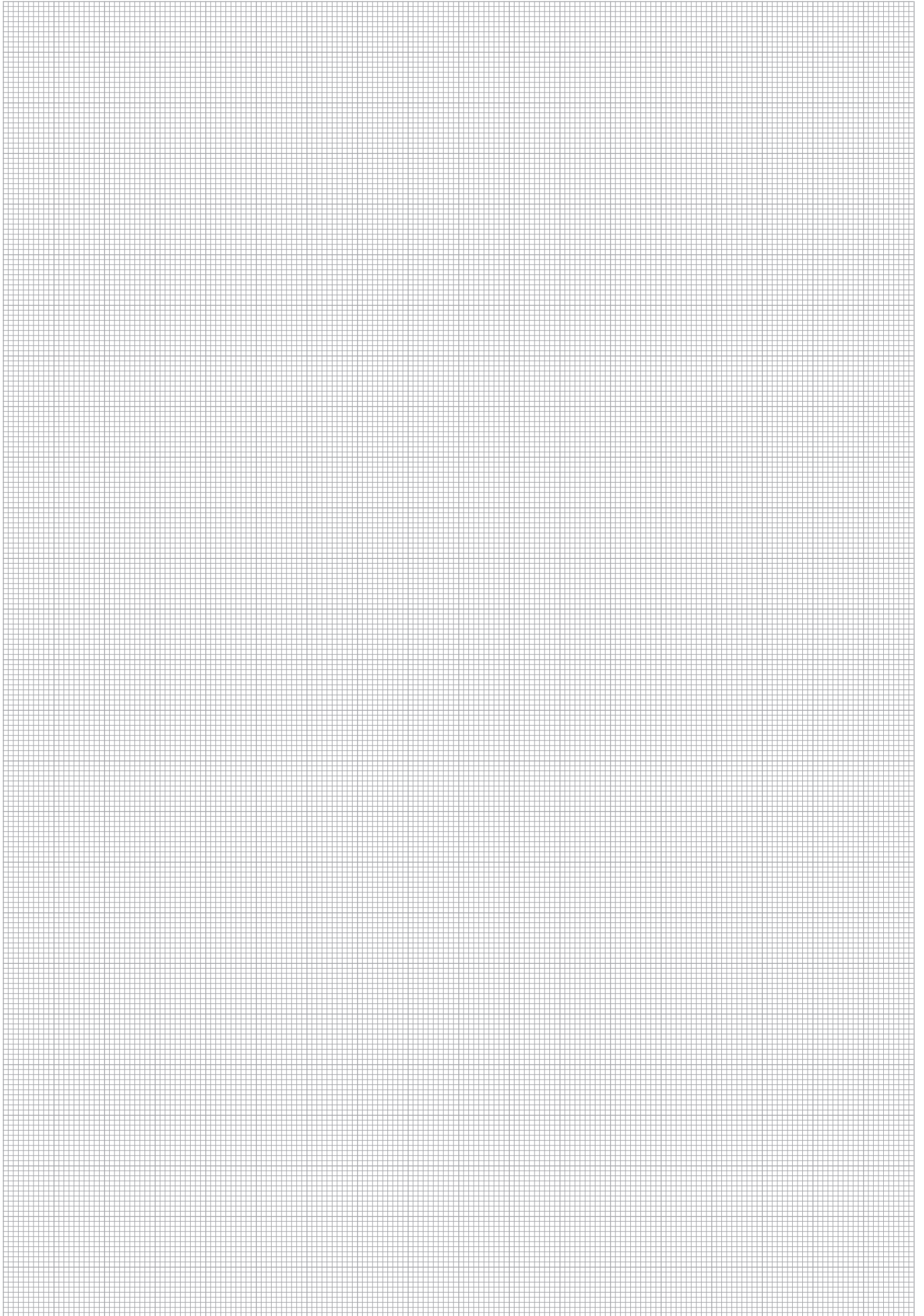

HT



Series HM • Carbon Steel and Brass

Series HM • Overview	174
Series HM-19 • BG 6 • Nominal Size 19	175
Series HM-25 • BG 8 • Nominal Size 25	175
Series HM-31 • BG 10 • Nominal Size 31,5	175
Series HM-38 • BG 12 • Nominal Size 38	175
Series HM • Dust Protection	176

HM

Series HM - Carbon Steel and Brass

Material	Brass and Carbon Steel
Surface Finishing	Carbon Steel: Zinc-Plating and Thick-Film-Passivation (Chrome III)
Standard Seal Material(s)	NBR (Buna-N®) ²
Working Temperature	-25° C ... +100° C / -13° F ... +212° F
Valve Design	Flat Valve
Connection	Screw
Disconnection	Screw
Connect Under Pressure	not allowed
Application	Industrial Hydraulic
ISO Interchange	-



Female Body

Male Tip

²Alternative seal materials are available on request.

Technical Data

Series	BG	DN Zoll	DN metric ISO 4397	Q _{max}		Working Pressure		Bursting Pressure Connected		Female Body		Male Tip		Spillage	
				l/min	US GPM	bar	PSI	bar	PSI	bar	PSI	bar	PSI	ml	fl oz
HM-19	6	3/4"	19 (20)	220	58.12	210	3046	1160	16824	580	8412	460	6672	0,15	.0051
HM-25	8	1"	25	260	68.68	210	3046	880	12763	720	10443	370	5366	0,4	.0135
HM-31	10	1 1/4"	31	400	105.67	190	2756	520	7542	570	8267	430	6237	0,65	.0220
HM-38	12	1 1/2"	38	600	158.50	170	2466	500	7252	350	5076	430	6237	0,85	.0287

The indicated pressure ratings only apply to the coupling itself and depend on the connection type.

Flow Characteristics

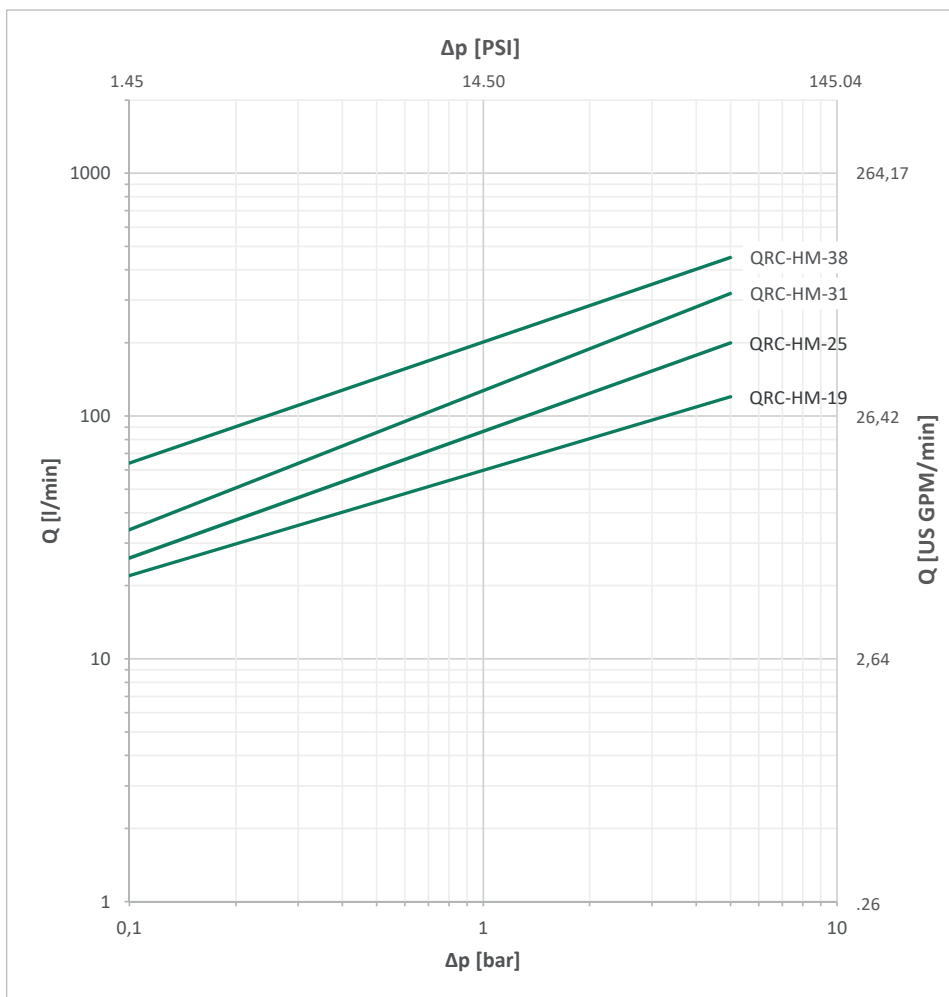

Please note: Unless otherwise stated, all flow characteristics have been determined with hydraulic oil with a kinematic viscosity of 28,8 - 35,2 mm²/s (28,8 - 35,2 cSt) and are only valid for components with non-reducing connections.

HM



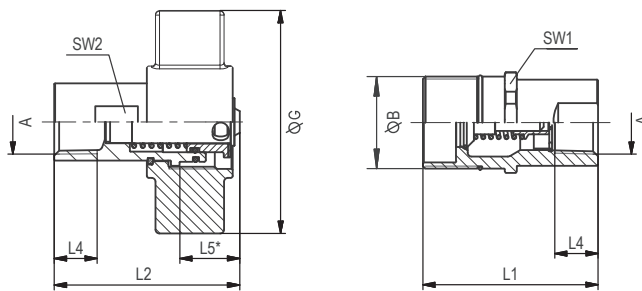

SW: Width across flats. All dimensions in mm (inch). Drawing similar Series HM-25.
* Insertion Male Tip.

Series HM-19 • BG 6 • Nominal Size 19

Port A	Dimensions (^{mm} / _{in})								Female Body		Weight (^{kg} / _{lbs}) ca. per 100	Male Tip		Weight (^{kg} / _{lbs}) ca. per 100
	ØB	ØG	L1	L2	L4 min	L5	SW1	SW2	Old Part Numbers	STAUFF Ordering Codes		Old Part Numbers	STAUFF Ordering Codes	
Female Thread according to ANSI B 1.20.3														
	NPTF 1/2" -14	1 1/2 - 12 UNF	102	79	80,5			41,3	28,6	HM19-1-INF08	63,50	HM19-2-INF08	43	
			4,01	3,11	3,17			1 5/8	1 1/8	QRC-HM-19-F-NF08-BT-W162	139,99	QRC-HM-19-M-NF08-B-W162	94,80	
	NPTF 3/4" -14	1 1/2 - 12 UNF	102	79	80,5			41,3	28,6	HM19-1-INF12	60,20	HM19-2-INF12	39,50	
			4,01	3,11	3,17			1 5/8	1 1/8	QRC-HM-19-F-NF12-BT-W162	132,72	QRC-HM-19-M-NF12-B-W162	87,08	

Series HM-25 • BG 8 • Nominal Size 25

Port A	Dimensions (^{mm} / _{in})								Female Body		Weight (^{kg} / _{lbs}) ca. per 100	Male Tip		Weight (^{kg} / _{lbs}) ca. per 100
	ØB	ØG	L1	L2	L4 min	L5	SW1	SW2	Old Part Numbers	STAUFF Ordering Codes		Old Part Numbers	STAUFF Ordering Codes	
Female Thread according to ANSI B 1.20.3														
	NPTF 1" -11 1/2	1 7/8 - 12 UN	114,5	90	95,3			48	36,3	HM25-1-INF16	104	HM25-2-INF16	63,30	
			4,50	3,54	3,75			1 7/8	1 7/16	QRC-HM-25-F-NF16-BT-W162	229,28	QRC-HM-25-M-NF16-B-W162	139,55	

Series HM-31 • BG 10 • Nominal Size 31,5

Port A	Dimensions (^{mm} / _{in})								Female Body		Weight (^{kg} / _{lbs}) ca. per 100	Male Tip		Weight (^{kg} / _{lbs}) ca. per 100
	ØB	ØG	L1	L2	L4 min	L5	SW1	SW2	Old Part Numbers	STAUFF Ordering Codes		Old Part Numbers	STAUFF Ordering Codes	
Female Thread according to ANSI B 1.20.3														
	NPTF 1 1/4" -11 1/2	2 1/8 - 12 UN	135	94,2	100			55,1	44,5	HM31-1-INF20	125,50	HM31-2-INF20	76,50	
			4,31	3,71	3,94			2 3/18	1 3/4	QRC-HM-31-F-NF20-BT-W162	276,68	QRC-HM-31-M-NF20-B-W162	168,65	

Series HM-38 • BG 12 • Nominal Size 38

Port A	Dimensions (^{mm} / _{in})								Female Body		Weight (^{kg} / _{lbs}) ca. per 100	Male Tip		Weight (^{kg} / _{lbs}) ca. per 100
	ØB	ØG	L1	L2	L4 min	L5	SW1	SW2	Old Part Numbers	STAUFF Ordering Codes		Old Part Numbers	STAUFF Ordering Codes	
Female Thread according to ANSI B 1.20.3														
	NPTF 1 1/2" -11 1/2	2 1/2 - 12 UN	135	104,5	103			63,5	50,8	HM38-1-INF24	155	HM38-2-INF24	116	
			5,31	4,11	4,06			2 1/2	2"	QRC-HM-38-F-NF24-BT-W162	341,72	QRC-HM-38-M-NF24-B-W162	255,74	

HM

Note: The connection of the two halves of a coupling is achieved depending on the type. It is important to observe the positive engagement of plug-type couplings and the secure tightening of screw-type couplings to the limit stop of the thread. Forced or improper separation will result in malfunction of the coupling.



Series HM • Dust Protection

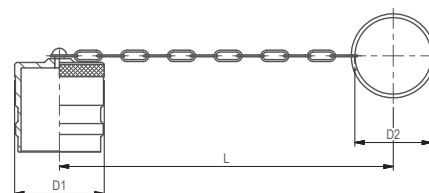
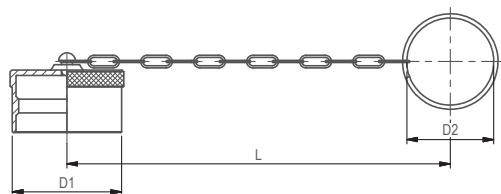

Dimensions (mm/in)			Material	Dust Plug for Female Body	
D1	D2	L		Old Part Numbers	STAUFF Ordering Codes
40	30	210	Brass with chain	HM19-0-MS001	
1.57	1.18	8.27		QRC-HM-19-DF-30/CN-W69	
48,0	41	270	Brass with chain	HM25-0-MS001	
1.89	1.61	10.63		QRC-HM-25-DF-41/CN-W69	
56	48	280	Brass with chain	HM31-0-MS001	
2.20	1.89	11.02		QRC-HM-31-DF-48/CN-W69	
63	48	280	Brass with chain	HM38-0-MS001	
2.48	1.89	11.02		QRC-HM-38-DF-48/CN-W69	

Dimensions (mm/in)			Material	Dust Cap for Male Tip	
D1	D2	L		Old Part Numbers	STAUFF Ordering Codes
41	30	210	Brass with chain	HM19-9-MS001	
1.61	1.18	8.27		QRC-HM-19-DM-30/CN-W69	
53	41	270	Brass with chain	HM25-9-MS001	
2.09	1.61	10.63		QRC-HM-25-DM-41/CN-W69	
62	48	280	Brass with chain	HM31-9-MS001	
2.44	1.89	11.02		QRC-HM-31-DM-48/CN-W69	
69	48	280	Brass with chain	HM38-9-MS001	
2.72	1.89	11.02		QRC-HM-38-DM-48/CN-W69	

HM



Series HV • Carbon Steel

Series HV • Overview	178
Series HV-19 • BG 6 • Nominal Size 19	179
Series HV-25 • BG 8 • Nominal Size 25	179
Series HV-31 • BG 10 • Nominal Size 31,5	179
Series HV-38 • BG 12 • Nominal Size 38	179
Series HV-51 • BG 14 • Nominal Size 51	180
Series HV • Dust Protection	180

HV

Series HV ▪ Carbon Steel

Material	Carbon Steel
Surface Finishing	Zinc-Plating and Thick-Film-Passivation (Chrome III)
Standard Seal Material(s)	NBR (Buna-N®) ²
Working Temperature	-25° C ... +100° C / -13° F ... +212° F
Valve Design	Poppet Valve
Connection	Screw
Disconnection	Screw
Connect Under Pressure	Male Tip and Female Body up to max. 100 bar / 1450 PSI allowed
Application	Industrial Hydraulic
ISO Interchange	-



Female Body Male Tip

²Alternative seal materials are available on request.

Technical Data

Series	BG	DN Zoll Inch	DN metric ISO 4397	Q _{max}		Working Pressure		Bursting Pressure Connected		Female Body		Male Tip		Spillage	
				l/min	US GPM	bar	PSI	bar	PSI	bar	PSI	bar	PSI	ml	fl oz
HV-19	6	3/4"	19 (20)	190	50.19	350	5076	1500	21756	750	10878	1400	20305	8	.2705
HV-25	8	1"	25	280	73.97	350	5076	1600	23206	900	13053	1500	21756	16	.5410
HV-31	10	1 1/4"	31	480	126.80	350	5076	1300	18855	850	12328	1600	23206	31	1.0482
HV-38	12	1 1/2"	38	700	184.92	350	5076	1200	17404	600	8702	900	13053	64	2.1641
HV-51	14	2"	51	1000	264.17	350	5076	1100	15954	500	7252	600	8702	141	4.7678

The indicated pressure ratings only apply to the coupling itself and depend on the connection type.

Flow Characteristics

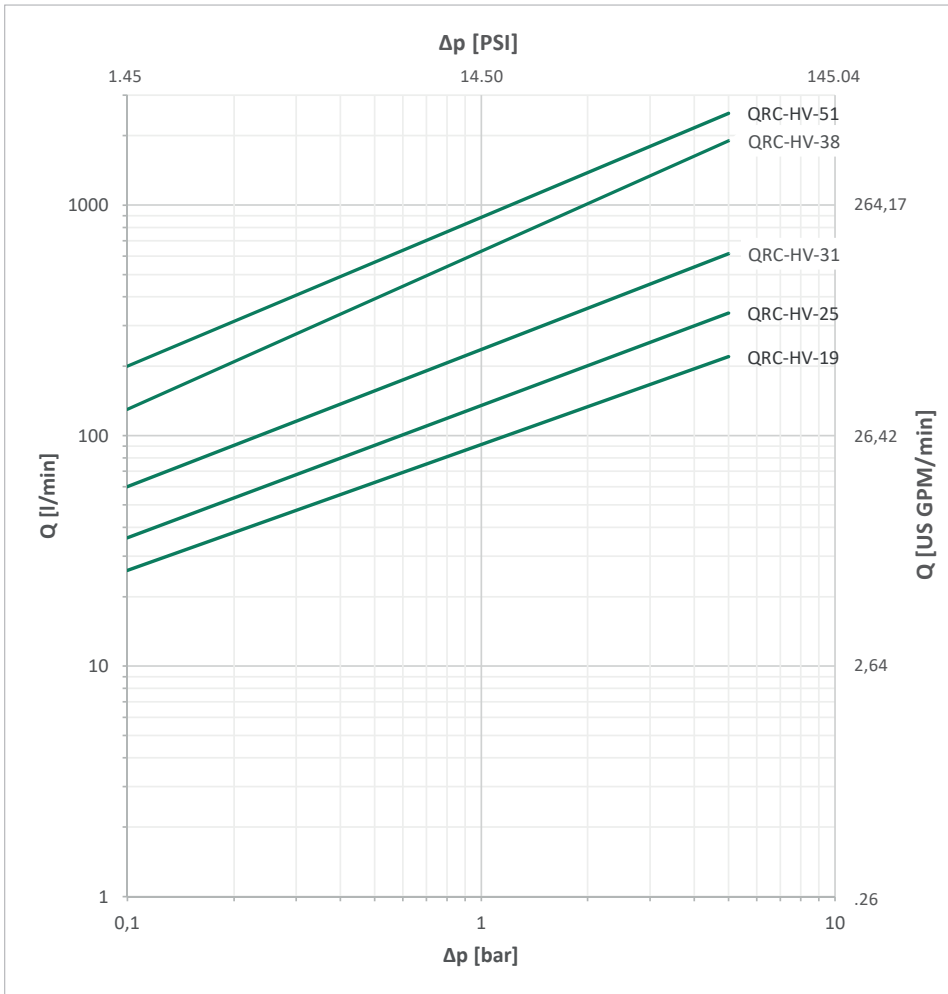

Please note: Unless otherwise stated, all flow characteristics have been determined with hydraulic oil with a kinematic viscosity of 28,8 - 35,2 mm²/s (28,8 - 35,2 cSt) and are only valid for components with non-reducing connections.



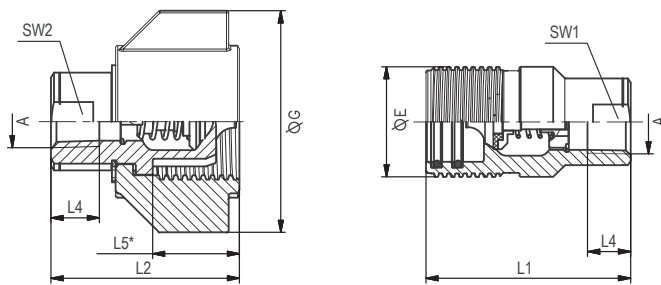

SW: Width across flats. All dimensions in mm (inch). Drawing similar Series HV-25.
* Insertion Male Tip.

Series HV-19 ▪ BG 6 ▪ Nominal Size 19

Port A	Dimensions (mm/in)	Female Body							Weight (kg/lbs) ca. per 100	Male Tip Old Part Numbers STAUFF Ordering Codes	Weight (kg/lbs) ca. per 100		
		ØE	ØG	L1	L2	L4 min	L5	SW1				SW2	
Female Thread according to ANSI B 1.20.3													
	NPTF 3/4" -14	44,5	72	83	62		22	31,8	31,8	HV19-1-INF12	84	HV19-2-INF12	48
		1.75	2.83	3.27	2.44		0.87	1"1/4	1"1/4	QRC-HV-19-F-NF12-BT-W66	185.19	QRC-HV-19-M-NF12-B-W66	105.82

Series HV-25 ▪ BG 8 ▪ Nominal Size 25

Port A	Dimensions (mm/in)	Female Body							Weight (kg/lbs) ca. per 100	Male Tip Old Part Numbers STAUFF Ordering Codes	Weight (kg/lbs) ca. per 100		
		ØE	ØG	L1	L2	L4 min	L5	SW1				SW2	
Female Thread according to ANSI B 1.20.3													
	NPTF 1" -11 1/2	57	102	106	87,6		39,95	41,3	41,3	HV25-1-INF16	114,50	HV25-2-INF16	110
		2.25	4.01	4.17	3.45		1.57	1"5/8	1"5/8	QRC-HV-25-F-NF16-BT-W66	252.43	QRC-HV-25-M-NF16-B-W66	242.51

Series HV-31 ▪ BG 10 ▪ Nominal Size 31,5

Port A	Dimensions (mm/in)	Female Body							Weight (kg/lbs) ca. per 100	Male Tip Old Part Numbers STAUFF Ordering Codes	Weight (kg/lbs) ca. per 100		
		ØE	ØG	L1	L2	L4 min	L5	SW1				SW2	
Female Thread according to ANSI B 1.20.3													
	NPTF 1 1/4" -11 1/2	66,5		136	113		51			HV31-1-INF20	253	HV31-2-INF20	187
		2.62		5.35	4.45		12.01			QRC-HV-31-F-NF20-BT-W66	557.77	QRC-HV-31-M-NF20-B-W66	412.26

Series HV-38 ▪ BG 12 ▪ Nominal Size 38

Port A	Dimensions (mm/in)	Female Body							Weight (kg/lbs) ca. per 100	Male Tip Old Part Numbers STAUFF Ordering Codes	Weight (kg/lbs) ca. per 100		
		ØE	ØG	L1	L2	L4 min	L5	SW1				SW2	
Female Thread according to ANSI B 1.20.3													
	NPTF 1 1/2" -11 1/2	82,5	140	152	133,3		64,3			HV38-1-INF24	401	HV38-2-INF24	310
		3.25	5.51	5.98	5.25		2.53			QRC-HV-38-F-NF24-BT-W66	884.05	QRC-HV-38-M-NF24-B-W66	683.43

HV

Note: The connection of the two halves of a coupling is achieved depending on the type. It is important to observe the positive engagement of plug-type couplings and the secure tightening of screw-type couplings to the limit stop of the thread. Forced or improper separation will result in malfunction of the coupling.



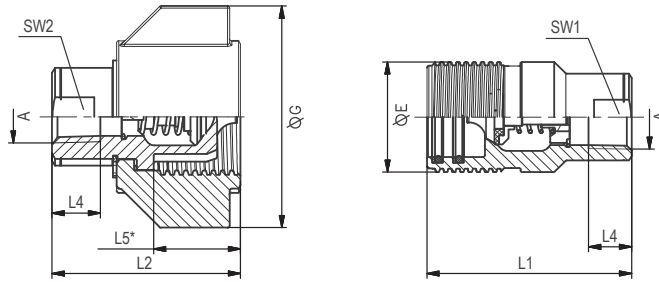

SW: Width across flats. All dimensions in mm (inch). Drawing similar Series HV-25.
* Insertion Male Tip.

Series HV-51 • BG 14 • Nominal Size 51

Port A	Dimensions (mm/in)	Female Body							Weight (^{kg} /lbs) ca. per 100	Male Tip	Weight (^{kg} /lbs) ca. per 100	
		ØE	ØG	L1	L2	L4 min	L5	SW1				SW2
Female Thread according to ANSI B 1.20.3		STAUFF Ordering Codes							per 100	STAUFF Ordering Codes	per 100	
	NPTF 2" -11 1/2	101	162	179	151,5		75,5		HV51-1-INF32	793,50	HV51-2-INF32	557
		3.97	6.37	7.05	5.96		2.97		QRC-HV-51-F-NF32-BT-W66	1749.67	QRC-HV-51-M-NF32-B-W66	1227.98

Series HV • Dust Protection



Dimensions (mm/in)			Material	Dust Plug for Female Body	
D1	D2	L		Old Part Numbers	STAUFF Ordering Codes
			Aluminium with chain	HV19-0-SI001*	QRC-HV-19-DF-CN-W89-SI*
69,5	48	270	Aluminium with chain	HV25-0-SI001	QRC-HV-25-DF-48/CN-W89-SI
2,74	1,89	10,63	Aluminium with chain	HV31-0-SI001	QRC-HV-31-DF-49/CN-W89-SI
75,5	49	270	Aluminium with chain	HV38-0-SI001	QRC-HV-38-DF-48/CN-W89-SI
2,97	1,93	10,63	Aluminium with chain	HV51-0-SI001*	QRC-HV-51-DF-CN-W89-SI*
95,5	48	280	Aluminium with chain		
3,76	1,89	11,02	Aluminium with chain		

Dimensions (mm/in)			Material	Dust Cap for Male Tip	
D1	D2	L		Old Part Numbers	STAUFF Ordering Codes
			Aluminium with chain	HV19-9-SI001*	QRC-HV-19-DM-CN-W89-SI*
70	48	270	Aluminium with chain	HV25-9-SI001	QRC-HV-25-DM-48/CN-W89-SI
2,76	1,89	10,63	Aluminium with chain	HV31-9-SI001	QRC-HV-31-DM-49/CN-W89-SI
80,5	49	270	Aluminium with chain	HV38-9-SI001	QRC-HV-38-DM-48/CN-W89-SI
3,17	1,93	10,63	Aluminium with chain	HV51-9-SI001*	QRC-HV-51-DM-CN-W89-SI*
96	48	280	Aluminium with chain		
3,78	1,89	11,02	Aluminium with chain		

* Available on request.

HV

Note: The connection of the two halves of a coupling is achieved depending on the type. It is important to observe the positive engagement of plug-type couplings and the secure tightening of screw-type couplings to the limit stop of the thread. Forced or improper separation will result in malfunction of the coupling.



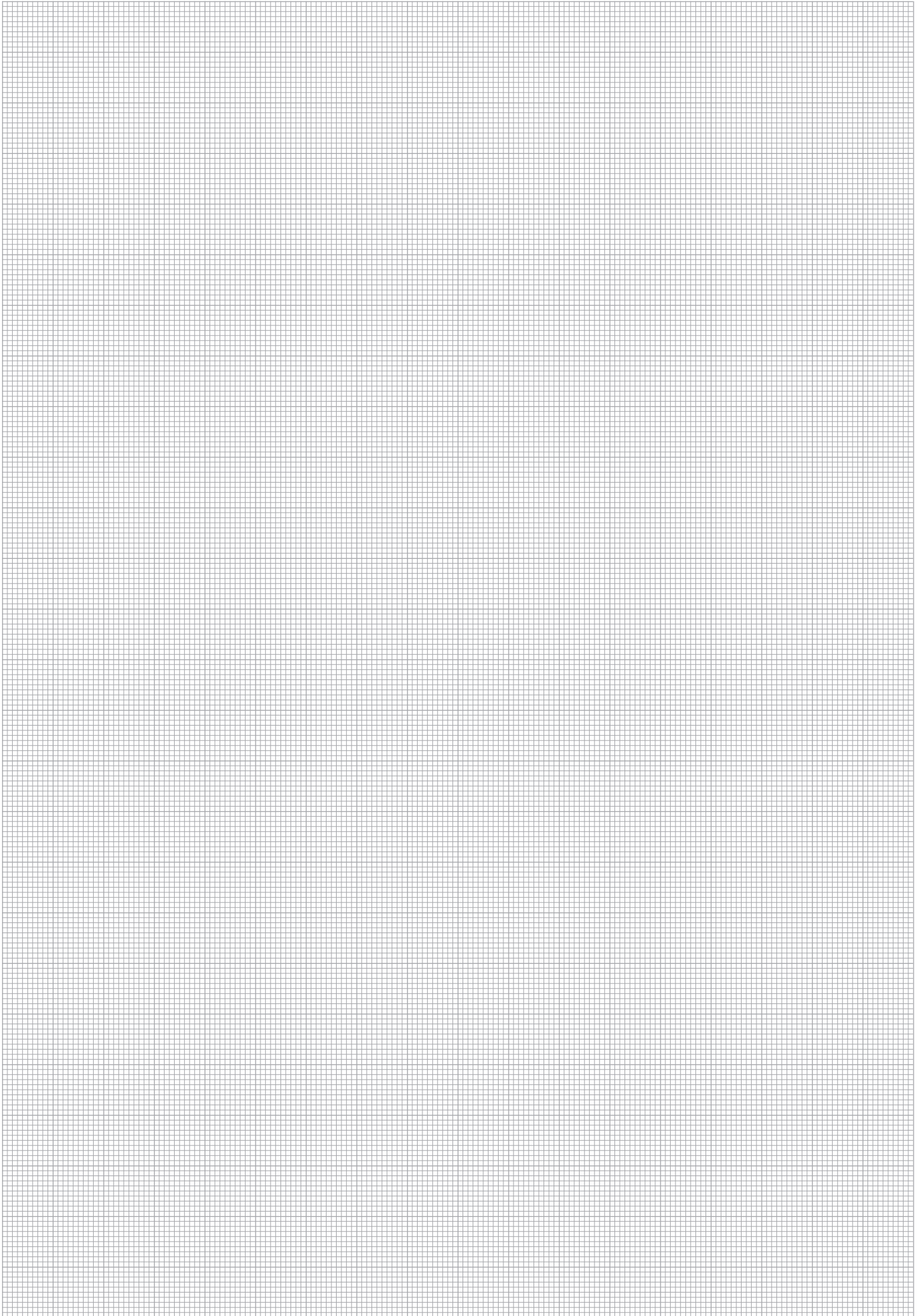





In addition of our common couplings series, we also have various special designs for a huge range of special applications, even outside the hydraulic area, in our portfolio.

We are open minded to find customized solutions for all kind of applications and different influencing factors and work them out for or together with our customers.

Water Application



Electro-technics

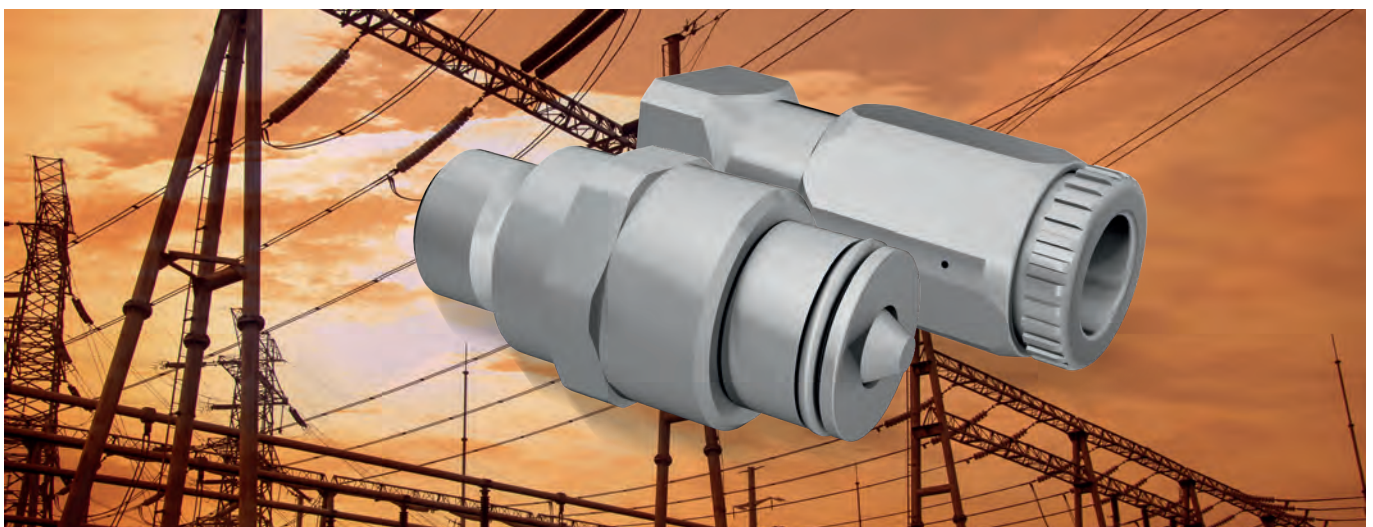

Note: The connection of the two halves of a coupling is achieved depending on the type. It is important to observe the positive engagement of plug-type couplings and the secure tightening of screw-type couplings to the limit stop of the thread. Forced or improper separation will result in malfunction of the coupling.



Automotive Engineering



Agricultural Engineering



Refrigeration



Note: The connection of the two halves of a coupling is achieved depending on the type. It is important to observe the positive engagement of plug-type couplings and the secure tightening of screw-type couplings to the limit stop of the thread. Forced or improper separation will result in malfunction of the coupling.





Dust cover clips	188
Dust cover body	188
Marking Clips	189
Safety Clamp with 4-hole flange	189
Anchor bracket for Male Tip	189
Seal Kits	190 - 191



Dust cover clips

Description

This dust guard can be fitted to the Female Body after installation for the Series HP and FF. The cap is also available with an optional drill hole for a marking clip.

In addition to the standard colour black, plastic dust caps are also available for the types HP-10 and the series FF in blue, green, yellow and red. Please use the old color codes BL, GN, GE and RT respectively instead of SW. Please use the STAUFF codes BU, GN, YE and RD respectively instead of BK. The types HP-08 and HP-12 are only available in black.

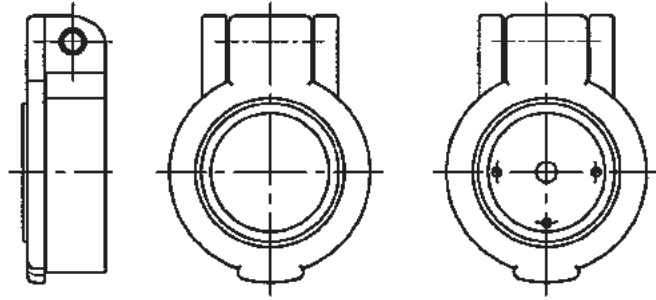

Type	Without bore	With bore
	Old Part Numbers STAUFF Ordering Codes	Old Part Numbers STAUFF Ordering Codes
HP-10 + FF-10		SZ08-6-SW001C1 QRC-SZ-SF-32/L-K-BK
UX-12/HP-12 + FF-12	SZ10-6-SW001A1 QRC-SZ-SF-38-K-BK	SZ10-6-SW002C1 QRC-SZ-SF-38/L-K-BK
HP-19 + FF-19		SZ12-6-SW002C1 QRC-SZ-SF-46/L-K-BK

Dust cover body

Description

The dust guard is used to protect the carrier half against pollution. The cap is also available with an optional drill hole for a marking clip.

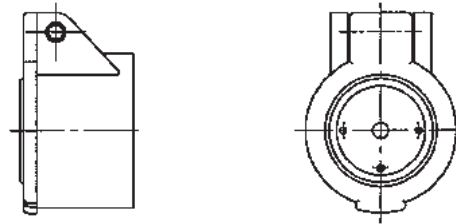

Type	Without bore	With bore
	Old Part Numbers STAUFF Ordering Codes	Old Part Numbers STAUFF Ordering Codes
RH-10	RH-08-7-SW001A1 QRC-RH-10-BF-30-K-BK	RH-08-7-SW001C1 QRC-RH-10-BF-30/L-K-BK



Marking Clips

Description

The marking clips are used for identification purposes.



Mark	Colour	Old Part Numbers
		STAUFF Ordering Codes
1	red	SZ00-5-RT100
		QRC-SZ-CL-1-K-RD
2	red	SZ00-5-RT200
		QRC-SZ-CL-2-K-RD
3	green	SZ00-5-GN300
		QRC-SZ-CL-3-K-GN
4	green	SZ00-5-GN400
		QRC-SZ-CL-4-K-GN
5	yellow	SZ00-5-GE500
		QRC-SZ-CL-5-K-YE
6	yellow	SZ00-5-GE600
		QRC-SZ-CL-6-K-YE
7	blue	SZ00-5-BL700
		QRC-SZ-CL-7-K-BU
8	blue	SZ00-5-BL800
		QRC-SZ-CL-8-K-BU
II	white	SZ00-5-WS005
		QRC-SZ-CL-R2-K-WH
III	white	SZ00-5-WS009
		QRC-SZ-CL-R3-K-WH
Rückl.	black	SZ00-5-SW004
		QRC-SZ-CL-T-K-BK
Neutr.	black	SZ00-5-SW001
		QRC-SZ-CL-K-BK

Safety Clamp with 4-hole flange

Description

This safety clamp enables the HP-10 Female Body to be rigidly secured on the vehicle. The carrier is held in the clamp by a spring.

Old Part Numbers
STAUFF Ordering Codes
SZ10-1-V0015
QRC-SZ-BH-38-W66

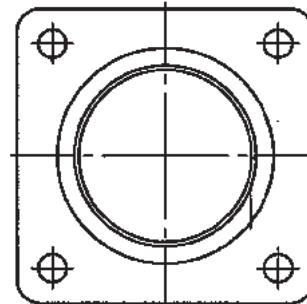

Anchor bracket for Male Tip

Description

The anchor bracket allows the Male Tip to be parked when disconnected. This protects the probe from damage and dirt. The anchor bracket is made of red plastic and fitted with a spring-loaded cap.

Old Part Numbers
STAUFF Ordering Codes
SZ10-1-RT001A0
QRC-HP-12-MH-M18-K-RD

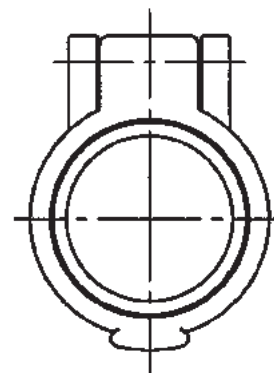
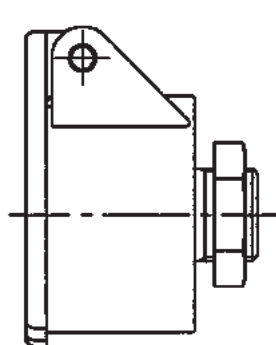

Seal Kits

Type	Description	Amount	Old Part Numbers	STAUFF Ordering Codes
for Female Body				
HP-06	O-ring Back up ring	25	HP04-1DICHTSATZ	QRC-HPA-06-FSK-BT
HP-10	O-ring Back up ring	25	HP08-1DICHTSATZ	QRC-HP-10-FSK-BT
HP-10A	O-ring Back up ring	20	HP-08A1DICHTSATZ	QRC-HPA-10-FSK-BT
HP-12	O-ring	50	HP10-1DICHTSATZ	QRC-HP-12-FSK-B
HP-19	O-ring Back up ring	25	HP12-1DICHTSATZ	QRC-HP-19-FSK-BT
HP-25	O-ring	25	HP20-1DICHTSATZ	QRC-HP-25-FSK-BT
for Male Tip				
FH-06	Profile packing	25	FH06-2DICHTSATZ	QRC-FH-06-MSK-PU
FH-10	O-ring Profile packing	25	FH10-2DICHTSATZ	QRC-FH-10-MSK-BT
FH-12	O-ring Profile packing	25	FH12-2DICHTSATZ	QRC-FH-12-MSK-BT
FH-16	Profile packing	25	FH16-2DICHTSATZ	QRC-FH-16-MSK-PU
FH-19	O-ring Profile packing	25	FH19-2DICHTSATZ	QRC-FH-19-MSK-BT
FH-25	O-ring PTFE ring	10	FH25-2DICHTSATZ	QRC-FH-25-MSK-BT
for Male Tip				
FF-06	Profile packing	25	FF06-2DICHTSATZ	QRC-FF-06-MSK-PU
FF-10	Profile packing	25	FF10-2DICHTSATZ	QRC-FF-10-MSK-PU
FF-12	Profile packing	25	FF12-2DICHTSATZ	QRC-FF-12-MSK-PU
FF-16	Profile packing	25	FF16-2DICHTSATZ	QRC-FF-16-MSK-PU
FF-19	Profile packing	25	FF19-2DICHTSATZ	QRC-FF-19-MSK-PU
FF-25	O-ring PTFE ring	10	FF25-2DICHTSATZ	QRC-FF-25-MSK-BT
for Female Body				
HS-06	O-ring Back up ring Arrest ring	25	HS04-1DICHTSATZ	QRC-HS-06-FSK-BT
HS-10	O-ring Back up ring Arrest ring	25	HS08-1DICHTSATZ	QRC-HS-10-FSK-BT
HS-12	O-ring Back up ring Arrest ring	50	HS10-1DICHTSATZ	QRC-HS-12-FSK-BT
HS-19	O-ring Back up ring Arrest ring	25	HS12-1DICHTSATZ	QRC-HS-19-FSK-BT
HS-25	O-ring Back up ring Arrest ring	25	HS20-1DICHTSATZ	QRC-HS-25-FSK-BT
HS-38	O-ring Back up ring Arrest ring	10	HS25-1DICHTSATZ	QRC-HS-38-FSK-BT

Note: Any disconnection of the coupling leads up to the expiration of the guarantee.



Seal Kits

Type	Description	Amount	Old Part Numbers	STAUFF Ordering Codes
for Male Tip				
FT-10	O-ring	10	FT10-2DICHTSATZ	QRC-FT-10-MSK-BT
	Profile packing			
FT-12	O-ring	10	FT12-2DICHTSATZ	QRC-FT-12-MSK-BT
	Profile packing			
FT-16	O-ring	10	FT16-2DICHTSATZ	QRC-FT-16-MSK-BT
	Profile packing			
FT-19	O-ring	10	FT19-2DICHTSATZ	QRC-FT-19-MSK-BT
	Profile packing			
FT-31	O-ring	10	FT32-2DICHTSATZ	QRC-FT-31-MSK-BT
	Profile packing			
for Female Body				
PS-25	Back up ring	5	PS-25-1DICHTSATZ	QRC-PS-25-FSK-S4
	O-ring			
for Female Body				
RH-10	O-ring	25	RH08-1DICHTSATZ	QRC-RH-10-FSK-BT
	Back up ring			
RH-12	O-ring	25	RH12-1DICHTSATZ	QRC-RH-12-FSK-BT
	Back up ring			
RH-16	O-ring	10	RH16-1DICHTSATZ	QRC-RH-16-FSK-BT
	Back up ring			
RK-19	O-ring	10	RK19-1DICHTSATZ	QRC-RK-19-FSK-BT
	Back up ring			
RH-25	O-ring	10	RH25-1DICHTSATZ	QRC-RH-25-FSK-BT
	Back up ring			

Note: Any disconnection of the coupling leads up to the expiration of the guarantee.







Safety Regulations for Handling of Quick Release Couplings and Accessories

Important !

Incorrect selection or incorrect and inexpert handling of couplings and accessories may result in property damage or personal injury.

- High velocity fluid discharge
- Explosion or combustion of the conveyed fluid
- Collision with moving or dropping components, caused by failure of a hydraulic circuit
- Dangerous whipping of hydraulic hoses
- Risk of injury through contacting hot, cold or otherwise dangerous fluids

Read and observe the following instructions prior to selecting and using a snap-in coupling or associated accessories.

1 General Notes

1.1 General

This section contains instructions on selection and handling (installation, coupling and uncoupling and maintenance). This is to be understood as additional safety notes and must be taken into consideration in the use and application of the products.

1.2 Safety Measures

Couplings may possibly fail without prior warning. Take this into consideration when planning the safety devices of your system or plant.

1.3 Information for the User

Forward these safety notes to the persons responsible for the selection and handling of couplings. Use only couplings for which you have received and understood product-specific information.

1.4 Responsibility of the User

Due to the versatile range of applications of couplings, not every application case and every technical detail can be dealt with in this document.

The user is responsible for:

- final selection of the product
- fulfilment of requirements by the operator
- safety of operating personnel and plant
- safety measures necessary in the use of couplings

Should you have any further questions, please contact our sales department.

2 Correct Selection of Couplings

2.1 Pressure Range

The coupling to be used must be selected so that the maximum permissible operating pressure is equal to or higher than the system pressure. Pressure peaks in the system in excess of the operating pressure reduce the service life of the couplings and therefore should be taken into consideration when making the selection.

2.2 Resistance to Media

The Sealing Materials in the couplings are suitable for a large variety of pressure media. Information on the compatibility of a particular type of fluid are available upon request from product manager.

2.3 Operating Temperature

The indication of operating temperatures in the technical specifications represents maximum values. These values may not be exceeded in standing or flowing circuits. For actuation the natural warming of the coupling must also be taken into consideration.

2.4 Size

The selection of the size and type of connection depends on the required transmission of forces. For this purpose, refer to the corresponding diagrams. Flow volume, pressure loss and flow speed should be taken into consideration when selecting the correct size of a coupling. Should these values be exceeded, malfunctions within the coupling may occur.

2.5 Mechanical Connection

The connection of the two halves of a coupling is achieved depending on the type. It is important to observe the positive engagement of plug-type couplings and the secure tightening of screw-type couplings to the limit stop of the thread. Forced or improper separation will result in malfunction of the coupling.

2.6 Thermal Stress

Excessive warming of the coupling above the recommended operating temperature, for instance due to welding or soldering, can cause the formation of dangerous gases. In addition, the protective surface finish (galvanization) will be damaged and the function of the coupling may be impaired.

2.7 Guidelines

Applicable specifications, standards and regulations as well as technical rules must be taken into consideration in the selection of couplings.



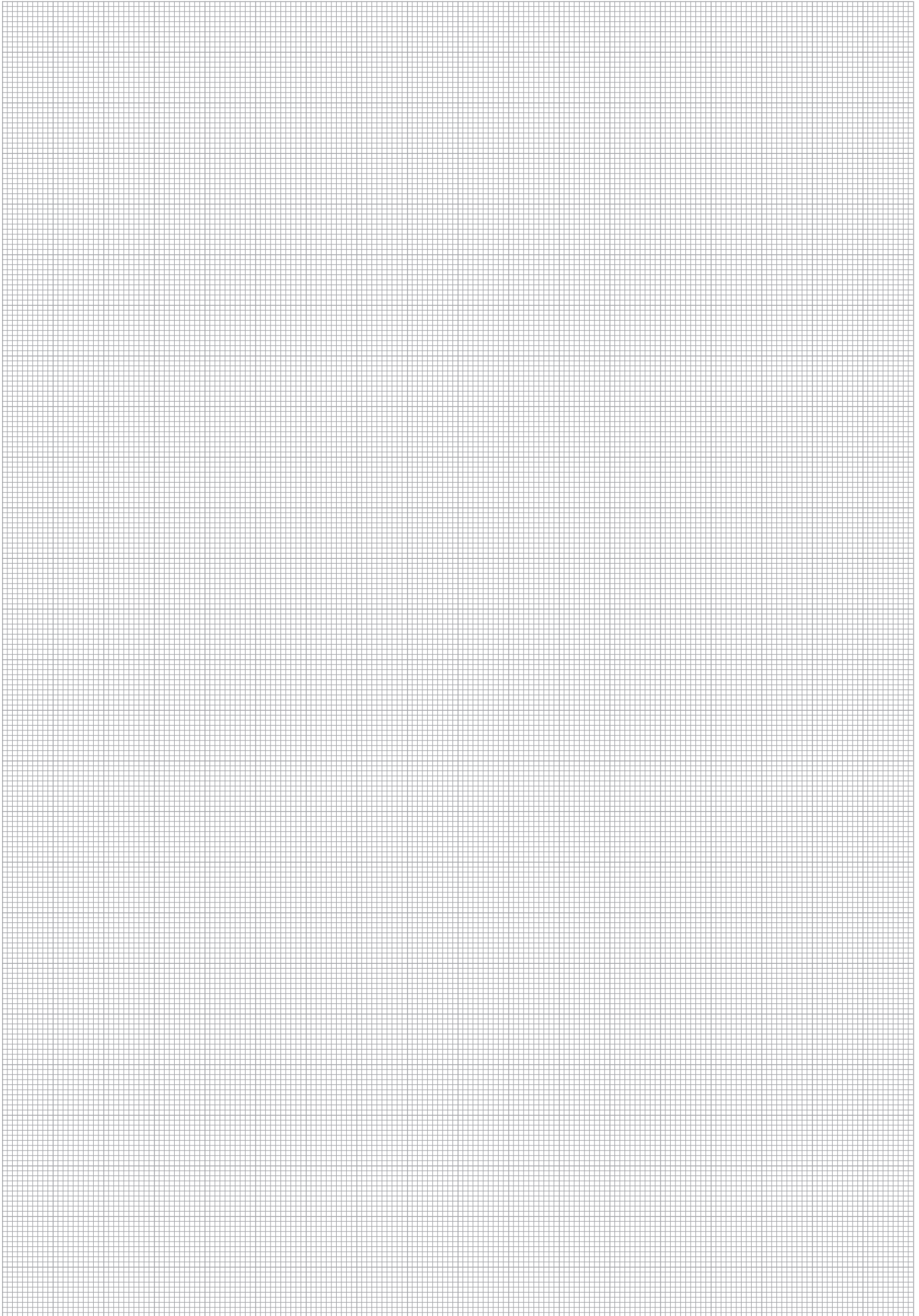



Product-Specific Abbreviations

198 - 201

Global Contact Directory

202 - 203



Product-Specific Abbreviations

Abbreviation	Product Category	Product Description	Page
FF-06	Push-to-Connect Couplings	Series FF-06 ■ BG 1 ■ Nominal Size 6,3	23
FF-10	Push-to-Connect Couplings	Series FF-10 ■ BG 2 ■ Nominal Size 10	24
FF-12	Push-to-Connect Couplings	Series FF-12 ■ BG 3 ■ Nominal Size 12,5	25
FF-16	Push-to-Connect Couplings	Series FF-16 ■ BG 4A ■ Nominal Size 16	26
FF-19	Push-to-Connect Couplings	Series FF-19 ■ BG 4 ■ Nominal Size 19	27
FF-25	Push-to-Connect Couplings	Series FF-25 ■ BG 5 ■ Nominal Size 25	28
FF-38	Push-to-Connect Couplings	Series FF-38 ■ BG 6 ■ Nominal Size 31,5	29
FH/FU 51	Push-to-Connect Couplings	Series FH/FU 51 ■ BG 7 ■ Nominal Size 50	29
FU-10	Push-to-Connect Couplings	Series FU-10 ■ BG 2 ■ Nominal Size 10	30
FU-12	Push-to-Connect Couplings	Series FU-12 ■ BG 3 ■ Nominal Size 12,5	30
FU-19	Push-to-Connect Couplings	Series FU-19 ■ BG 4 ■ Nominal Size 19	30
FF/FH/FU ■ Dust Protection	Push-to-Connect Couplings	Series FF/FH/FU ■ Dust Protection	31
FH-10 ■ Stainless Steel	Push-to-Connect Couplings	Series FH-10 ■ BG 2 ■ Nominal Size 10	35
FH-12 ■ Stainless Steel	Push-to-Connect Couplings	Series FH-12 ■ BG 3 ■ Nominal Size 12,5	35
FH-19 ■ Stainless Steel	Push-to-Connect Couplings	Series FH-19 ■ BG 6 ■ Nominal Size 19	36
FO-06 ■ Stainless Steel	Push-to-Connect Couplings	Series FO-06 ■ BG 1 ■ Nominal Size 6,3	39
FO-10 ■ Stainless Steel	Push-to-Connect Couplings	Series FO-10 ■ BG 2 ■ Nominal Size 10	39
FO-12 ■ Stainless Steel	Push-to-Connect Couplings	Series FO-12 ■ BG 3 ■ Nominal Size 12,5	39
FO-19 ■ Stainless Steel	Push-to-Connect Couplings	Series FO-19 ■ BG 6 ■ Nominal Size 19	39
FO-25 ■ Stainless Steel	Push-to-Connect Couplings	Series FO-25 ■ BG 8 ■ Nominal Size 25	40
HP-06	Push-to-Connect Couplings	Series HP-06 ■ BG 1 ■ Nominal Size 6,3	43
HP-10	Push-to-Connect Couplings	Series HP-10 ■ BG 2 ■ Nominal Size 10	44
HP-10A	Push-to-Connect Couplings	Series HP-10A ■ BG 2 ■ Nominal Size 10	45
HP-12	Push-to-Connect Couplings	Series HP-12 ■ BG 3 ■ Nominal Size 12,5	46-47
ZP-12	Push-to-Connect Couplings	Series ZP-12 ■ BG 3 ■ Nominal Size 12,5	48
AP-12	Push-to-Connect Couplings	Series AP-12 ■ BG 3 ■ Nominal Size 12,5	49
HP-19	Push-to-Connect Couplings	Series HP-19 ■ BG 6 ■ Nominal Size 19	50
HP-25	Push-to-Connect Couplings	Series HP-25 ■ BG 8 ■ Nominal Size 25	51
HU-12	Push-to-Connect Couplings	Series HU-12 ■ BG 3 ■ Nominal Size 12,5	49
HP/HU ■ Dust Protection	Push-to-Connect Couplings	Series HP und Series HU ■ Dust Protection	52
UX-12 ■ short version	Push-to-Connect Couplings	Series UX-S-12 ■ BG 3 ■ Nominal Size 12,5 ■ short version	55
UX-12 ■ long version	Push-to-Connect Couplings	Series UX-L-12 ■ BG 3 ■ Nominal Size 12,5 ■ long version	56
IA-06	Push-to-Connect Couplings	Series IA-06 ■ BG 1 ■ Nominal Size 6,3	59
IA-10	Push-to-Connect Couplings	Series IA-10 ■ BG 2 ■ Nominal Size 10	59
IA-12	Push-to-Connect Couplings	Series IA-12 ■ BG 3 ■ Nominal Size 12,5	60
IA-19	Push-to-Connect Couplings	Series IA-19 ■ BG 6 ■ Nominal Size 19	60
IA-25	Push-to-Connect Couplings	Series IA-25 ■ BG 8 ■ Nominal Size 25	61
IA-31	Push-to-Connect Couplings	Series IA-31 ■ BG 10 ■ Nominal Size 31,5	61
IA-38	Push-to-Connect Couplings	Series IA-38 ■ BG 12 ■ Nominal Size 38	61
IA-51	Push-to-Connect Couplings	Series IA-51 ■ BG 14 ■ Nominal Size 51	61
IA ■ Dust Protection	Push-to-Connect Couplings	Series IA ■ Dust Protection	62
IA-06 ■ Stainless Steel	Push-to-Connect Couplings	Series IA-06 ■ BG 1 ■ Nominal Size 6,3	65
IA-10 ■ Stainless Steel	Push-to-Connect Couplings	Series IA-10 ■ BG 2 ■ Nominal Size 10	65
IA-12 ■ Stainless Steel	Push-to-Connect Couplings	Series IA-12 ■ BG 3 ■ Nominal Size 12,5	65
IA-19 ■ Stainless Steel	Push-to-Connect Couplings	Series IA-19 ■ BG 6 ■ Nominal Size 19	65
IA-25 ■ Stainless Steel	Push-to-Connect Couplings	Series IA-25 ■ BG 8 ■ Nominal Size 25	66
IA-31 ■ Stainless Steel	Push-to-Connect Couplings	Series IA-31 ■ BG 10 ■ Nominal Size 31,5	66
IA-38 ■ Stainless Steel	Push-to-Connect Couplings	Series IA-38 ■ BG 12 ■ Nominal Size 38	66
IA-51 ■ Stainless Steel	Push-to-Connect Couplings	Series IA-51 ■ BG 14 ■ Nominal Size 51	66
IA ■ Stainless Steel ■ Dust Protection	Push-to-Connect Couplings	Series IA ■ Dust Protection	67
IB-03	Push-to-Connect Couplings	Series IB-03 ■ BG 0 ■ Nominal Size 3,2	71
IB-06	Push-to-Connect Couplings	Series IB-06 ■ BG 1 ■ Nominal Size 6,3	71
IB-10	Push-to-Connect Couplings	Series IB-10 ■ BG 2 ■ Nominal Size 10	71
IB-12	Push-to-Connect Couplings	Series IB-12 ■ BG 3 ■ Nominal Size 12,5	72
IB-19	Push-to-Connect Couplings	Series IB-19 ■ BG 6 ■ Nominal Size 19	72
IB-25	Push-to-Connect Couplings	Series IB-25 ■ BG 8 ■ Nominal Size 25	72
IB-38	Push-to-Connect Couplings	Series IB-38 ■ BG 12 ■ Nominal Size 38	73
IB-51	Push-to-Connect Couplings	Series IB-51 ■ BG 14 ■ Nominal Size 51	73
IB ■ Dust Protection	Push-to-Connect Couplings	Series IB ■ Dust Protection	74
IB-06 ■ Brass	Push-to-Connect Couplings	Series IB-06 ■ BG 1 ■ Nominal Size 6,3	77
IB-10 ■ Brass	Push-to-Connect Couplings	Series IB-10 ■ BG 2 ■ Nominal Size 10	77
IB-12 ■ Brass	Push-to-Connect Couplings	Series IB-12 ■ BG 3 ■ Nominal Size 12,5	77
IB-19 ■ Brass	Push-to-Connect Couplings	Series IB-19 ■ BG 6 ■ Nominal Size 19	77
IB-25 ■ Brass	Push-to-Connect Couplings	Series IB-25 ■ BG 8 ■ Nominal Size 25	78
IB-38 ■ Brass	Push-to-Connect Couplings	Series IB-38 ■ BG 12 ■ Nominal Size 38	78
IB-51 ■ Brass	Push-to-Connect Couplings	Series IB-51 ■ BG 14 ■ Nominal Size 51	78
IB ■ Brass ■ Dust Protection	Push-to-Connect Couplings	Series IB ■ Dust Protection	79



Product-Specific Abbreviations

Abbreviation	Product Category	Product Description	Page
IB-06 ■ Stainless Steel	Push-to-Connect Couplings	Series IB-06 ■ BG 1 ■ Nominal Size 6,3	83
IB-10 ■ Stainless Steel	Push-to-Connect Couplings	Series IB-10 ■ BG 2 ■ Nominal Size 10	83
IB-12 ■ Stainless Steel	Push-to-Connect Couplings	Series IB-12 ■ BG 3 ■ Nominal Size 12,5	83
IB-19 ■ Stainless Steel	Push-to-Connect Couplings	Series IB-19 ■ BG 6 ■ Nominal Size 19	83
IB-25 ■ Stainless Steel	Push-to-Connect Couplings	Series IB-25 ■ BG 8 ■ Nominal Size 25	84
IB-38 ■ Stainless Steel	Push-to-Connect Couplings	Series IB-38 ■ BG 12 ■ Nominal Size 38	84
IB-51 ■ Stainless Steel	Push-to-Connect Couplings	Series IB-51 ■ BG 14 ■ Nominal Size 51	84
IB ■ Stainless Steel ■ Dust Protection	Push-to-Connect Couplings	Series IB ■ Dust Protection	85
ID-06	Push-to-Connect Couplings	Series ID-06 ■ BG 1 ■ Nominal Size 6,3	89
ID-10	Push-to-Connect Couplings	Series ID-10 ■ BG 2 ■ Nominal Size 10	89
ID-19	Push-to-Connect Couplings	Series ID-19 ■ BG 6 ■ Nominal Size 19	89
ID-25	Push-to-Connect Couplings	Series ID-25 ■ BG 8 ■ Nominal Size 25	89
ID ■ Dust Protection	Push-to-Connect Couplings	Series ID ■ Dust Protection	90
BP-12	Push-to-Connect Couplings	Series BP-12 ■ BG 3 ■ Nominal Size 12,5	93
BP ■ Dust Protection	Push-to-Connect Couplings	Series BP ■ Dust Protection	93
HC-06	Push-to-Connect Couplings	Series HC-06 ■ BG 1 ■ Nominal Size 6,3	97
HC ■ Dust Protection	Push-to-Connect Couplings	Series HC ■ Dust Protection	97
HD-06	Push-to-Connect Couplings	Series HD-06 ■ BG 1 ■ Nominal Size 6,3	101
HD ■ Dust Protection	Push-to-Connect Couplings	Series HD ■ Dust Protection	101
HUS-10	Push-to-Connect Couplings	Series HUS-10 ■ BG 2 ■ Nominal Size 10	105
HUS-12	Push-to-Connect Couplings	Series HUS-12 ■ BG 3 ■ Nominal Size 12	105
HUS-19	Push-to-Connect Couplings	Series HUS-19 ■ BG 6 ■ Nominal Size 19	105
HUS-25	Push-to-Connect Couplings	Series HUS-25 ■ BG 8 ■ Nominal Size 25	105
HUS ■ Dust Protection	Push-to-Connect Couplings	Series HUS ■ Dust Protection	105
MK-Q-10/4	Multi Couplings	Series MK-Q-10/4 ■ BG 2 ■ Nominal Size 10	109
MK-R-10/4	Multi Couplings	Series MK-R-10/4 ■ BG 2 ■ Nominal Size 10	110
HS-06	Screw-to-Connect Couplings	Series HS-06 ■ BG 1 ■ Nominal Size 6,3	115
HS-10	Screw-to-Connect Couplings	Series HS-10 ■ BG 2 ■ Nominal Size 10	116
HS-12	Screw-to-Connect Couplings	Series HS-12 ■ BG 3 ■ Nominal Size 12,5	117-118
HS-19	Screw-to-Connect Couplings	Series HS-19 ■ BG 6 ■ Nominal Size 19	119
HS-25	Screw-to-Connect Couplings	Series HS-25 ■ BG 8 ■ Nominal Size 25	120-121
HS-38	Screw-to-Connect Couplings	Series HS-38 ■ BG 12 ■ Nominal Size 38	122
HS ■ Special Designs	Screw-to-Connect Couplings	Series HS ■ Special Designs	123
HS ■ Dust Protection	Screw-to-Connect Couplings	Series HS ■ Dust Protection	124
HS-06 ■ Stainless Steel	Screw-to-Connect Couplings	Series HS-06 ■ BG 1 ■ Nominal Size 6,3	127
HS-10 ■ Stainless Steel	Screw-to-Connect Couplings	Series HS-10 ■ BG 2 ■ Nominal Size 10	127
HS-12 ■ Stainless Steel	Screw-to-Connect Couplings	Series HS-12 ■ BG 3 ■ Nominal Size 12,5	127
HS-19 ■ Stainless Steel	Screw-to-Connect Couplings	Series HS-19 ■ BG 6 ■ Nominal Size 19	127
HS-25 ■ Stainless Steel	Screw-to-Connect Couplings	Series HS-25 ■ BG 8 ■ Nominal Size 25	128
HS-38 ■ Stainless Steel	Screw-to-Connect Couplings	Series HS-38 ■ BG 12 ■ Nominal Size 38	128
HS ■ Stainless Steel ■ Dust Protection	Screw-to-Connect Couplings	Series HS ■ Dust Protection	129
PS-25	Screw-to-Connect Couplings	Series PS-25 ■ BG 08 ■ Nominal Size 25	133
PS ■ Dust Protection	Screw-to-Connect Couplings	Series PS ■ Dust Protection	133
RH-10	Screw-to-Connect Couplings	Series RH-10 ■ BG 2 ■ Nominal Size 10	137
RH-12	Screw-to-Connect Couplings	Series RH-12 ■ BG 3 ■ Nominal Size 12,5	137
RH-16	Screw-to-Connect Couplings	Series RH-16 ■ BG 4 ■ Nominal Size 16	138
RK-19	Screw-to-Connect Couplings	Series RK-19 ■ BG 6 ■ Nominal Size 19	138
RH-25	Screw-to-Connect Couplings	Series RH-25 ■ BG 8 ■ Nominal Size 25	139
RH/RK ■ Dust Protection	Screw-to-Connect Couplings	Series RH/RK ■ Dust Protection	139
FT-10	Screw-to-Connect Couplings	Series FT-10 ■ BG 2 ■ Nominal Size 10	143
FT-12	Screw-to-Connect Couplings	Series FT-12 ■ BG 3 ■ Nominal Size 12,5	143
FT-16	Screw-to-Connect Couplings	Series FT-16 ■ BG 4 ■ Nominal Size 16	144
FT-19	Screw-to-Connect Couplings	Series FT-19 ■ BG 6 ■ Nominal Size 19	144
FT-25	Screw-to-Connect Couplings	Series FT-25 ■ BG 8 ■ Nominal Size 25	145
FT-31	Screw-to-Connect Couplings	Series FT-31 ■ BG 10 ■ Nominal Size 31,5	145
FT ■ Dust Protection	Screw-to-Connect Couplings	Series FT ■ Dust Protection	146
HR-10	Screw-to-Connect Couplings	Series HR-10 ■ BG 2 ■ Nominal Size 10	149
HR-12	Screw-to-Connect Couplings	Series HR-12 ■ BG 3 ■ Nominal Size 12,5	149
HR-19	Screw-to-Connect Couplings	Series HR-19 ■ BG 6 ■ Nominal Size 19	149
HR-25	Screw-to-Connect Couplings	Series HR-25 ■ BG 8 ■ Nominal Size 25	149
HR-31	Screw-to-Connect Couplings	Series HR-31 ■ BG 10 ■ Nominal Size 31,5	150
HR-38	Screw-to-Connect Couplings	Series HR-38 ■ BG 12 ■ Nominal Size 38	150
HR ■ Dust Protection	Screw-to-Connect Couplings	Series HR ■ Dust Protection	151



Product-Specific Abbreviations

Abbreviation	Product Category	Product Description	Page
HH-10	Screw-to-Connect Couplings	Series HH-10 ▪ BG 2 ▪ Nominal Size 10	155
HH-12	Screw-to-Connect Couplings	Series HH-12 ▪ BG 3 ▪ Nominal Size 12,5	155
HH-19	Screw-to-Connect Couplings	Series HH-19 ▪ BG 6 ▪ Nominal Size 19	155
HH-25	Screw-to-Connect Couplings	Series HH-25 ▪ BG 8 ▪ Nominal Size 25	155
HH-31	Screw-to-Connect Couplings	Series HH-31 ▪ BG 10 ▪ Nominal Size 31,5	156
HH-38	Screw-to-Connect Couplings	Series HH-38 ▪ BG 12 ▪ Nominal Size 38	156
HH-51	Screw-to-Connect Couplings	Series HH-51 ▪ BG 14 ▪ Nominal Size 51	156
HH ▪ Dust Protection	Screw-to-Connect Couplings	Series HH ▪ Dust Protection	157
HH-10 ▪ Stainless Steel	Screw-to-Connect Couplings	Series HH-10 ▪ BG 2 ▪ Nominal Size 10	161
HH-12 ▪ Stainless Steel	Screw-to-Connect Couplings	Series HH-12 ▪ BG 3 ▪ Nominal Size 12,5	161
HH-19 ▪ Stainless Steel	Screw-to-Connect Couplings	Series HH-19 ▪ BG 6 ▪ Nominal Size 19	161
HH-25 ▪ Stainless Steel	Screw-to-Connect Couplings	Series HH-25 ▪ BG 8 ▪ Nominal Size 25	161
HH-31 ▪ Stainless Steel	Screw-to-Connect Couplings	Series HH-31 ▪ BG 10 ▪ Nominal Size 31,5	162
HH-38 ▪ Stainless Steel	Screw-to-Connect Couplings	Series HH-38 ▪ BG 12 ▪ Nominal Size 38	162
HH-51 ▪ Stainless Steel	Screw-to-Connect Couplings	Series HH-51 ▪ BG 14 ▪ Nominal Size 51	162
HH ▪ Stainless Steel ▪ Dust Protection	Screw-to-Connect Couplings	Series HH ▪ Dust Protection	163
HI-06	Screw-to-Connect Couplings	Series HI-06 ▪ BG 1 ▪ Nominal Size 6,3	167
HI-10	Screw-to-Connect Couplings	Series HI-10 ▪ BG 2 ▪ Nominal Size 10	167
HT-19	Screw-to-Connect Couplings	Series HT-19 ▪ BG 6 ▪ Nominal Size 19	171
HT-25	Screw-to-Connect Couplings	Series HT-25 ▪ BG 8 ▪ Nominal Size 25	171
HT ▪ Dust Protection	Screw-to-Connect Couplings	Series HT ▪ Dust Protection	171
HM-19	Screw-to-Connect Couplings	Series HM-19 ▪ BG 6 ▪ Nominal Size 19	175
HM-25	Screw-to-Connect Couplings	Series HM-25 ▪ BG 8 ▪ Nominal Size 25	175
HM-31	Screw-to-Connect Couplings	Series HM-31 ▪ BG 10 ▪ Nominal Size 31,5	175
HM-38	Screw-to-Connect Couplings	Series HM-38 ▪ BG 12 ▪ Nominal Size 38	175
HM ▪ Dust Protection	Screw-to-Connect Couplings	Series HM ▪ Dust Protection	176
HV-19	Screw-to-Connect Couplings	Series HV-19 ▪ BG 6 ▪ Nominal Size 19	179
HV-25	Screw-to-Connect Couplings	Series HV-25 ▪ BG 8 ▪ Nominal Size 25	179
HV-31	Screw-to-Connect Couplings	Series HV-31 ▪ BG 10 ▪ Nominal Size 31,5	179
HV-38	Screw-to-Connect Couplings	Series HV-38 ▪ BG 12 ▪ Nominal Size 38	179
HV-51	Screw-to-Connect Couplings	Series HV-51 ▪ BG 14 ▪ Nominal Size 51	180
HV ▪ Dust Protection	Screw-to-Connect Couplings	Series HV ▪ Dust Protection	180



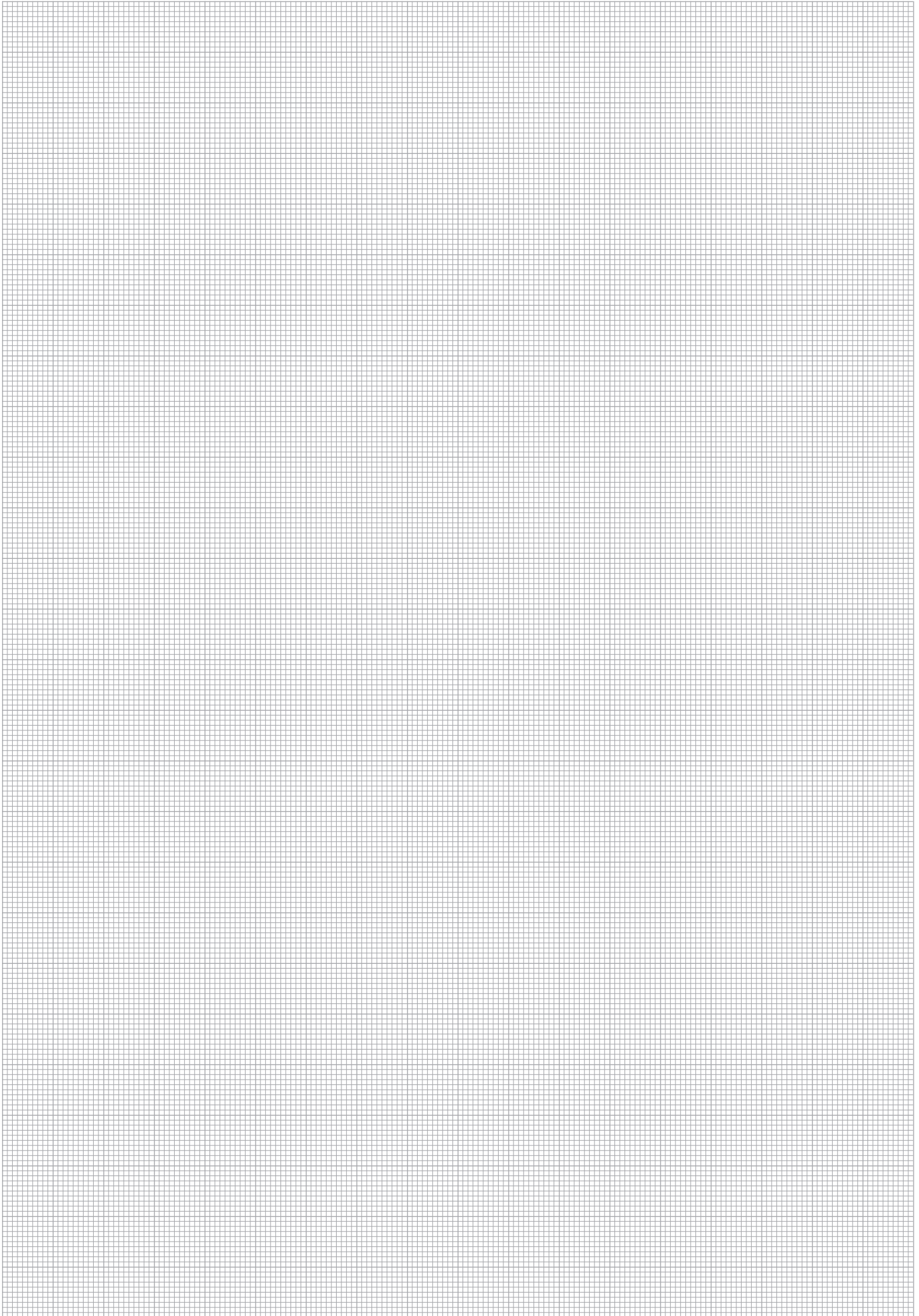

Global Contact Directory

STAUFF products and services are globally available through wholly-owned subsidiaries and a tight network of authorised distributors and representatives in all major industrial regions of the world.

Contact information on this page may be subject to changes and additions over time. Frequently updated and complete contact information can always be found at www.stauff.com.

Germany



Walter Stauffenberg GmbH & Co. KG
Im Ehrenfeld 4
58791 Werdohl
Tel.: +49 2392 91 60
Fax: +49 2392 91 61 03
E-Mail: sales@stauff.com
www.stauff.com



Neuenrade-Küntrop Logistics Centre
Wasserburgstraße 35
58809 Neuenrade



Plettenberg-Ohle Production Site
Lennestraße 2
58840 Plettenberg



Meinerzhagen Production Site
Neugrünenthal
58540 Meinerzhagen

Europe

France

STAUFF S.A.S.
230, Avenue du Grain d'Or
Z.I. de Vineuil - Blois Sud
41354 Vineuil-cedex
Tel.: +33 2 54 50 55 50
Fax: +33 2 54 42 29 19
E-Mail: direction@stauffsa.com
www.stauff.fr

Ireland

STAUFF UK Ltd.
Block B, 9 Ferguson Drive
Knockmore Hill Industrial Estate
Lisburn, County Antrim, BT28 2EX
Tel.: +44 2892 60 69 00
Fax: +44 2892 60 26 88
E-Mail: sales@stauffireland.com
www.stauff.co.uk

Italy

STAUFF Italia s.r.l
Via Borima 21 (Frazione Borima)
23867 Suello (LC)
Tel.: +39 031 65 84 94
Fax: +39 031 65 50 05
E-Mail: sales@stauff.it
www.stauff.it

Poland

STAUFF Polska Sp. z o.o.
Miszewko 43 A
80-297 Banino
Tel.: +48 58 660 11 60
Fax: +48 58 629 79 52
E-Mail: sales@stauff.pl
www.stauff.pl

Russian Federation

STAUFF LLC
Building 1
19, Leninskaya Sloboda
Moscow, 115280
Tel.: +7 495 276 16 50
Fax: +7 495 276 16 51
E-Mail: sales@stauff.ru
www.stauff.ru

United Kingdom

STAUFF UK Ltd.
500, Carlisle Street East
Off Downgate Drive
Sheffield, S4 8BS
Tel.: +44 114 251 85 18
Fax: +44 114 251 85 19
E-Mail: sales@stauff.co.uk
www.stauff.co.uk

STAUFF UK Ltd.
Badentoy Avenue
Badentoy Industrial Estate
Portlethen, Aberdeen, AB12 4YB
Tel.: +44 1224 78 61 66
Fax: +44 1224 78 61 77
E-Mail: sales@stauffscotland.co.uk
www.stauff.co.uk

STAUFF UK Ltd.
Unit 9, Southampton Trade Park
Third Avenue, Millbrook
Southampton, SO15 0AD
Tel.: +44 2380 69 87 00
Fax: +44 2380 69 87 01
E-Mail: sales@stauffsouthampton.co.uk
www.stauff.co.uk

Further branch offices in
Engels, Volzhskiy, Magnitogorsk,
Nizhny Novgorod and St. Petersburg.

North America

Canada

STAUFF Canada Ltd.
866 Milner Avenue
Scarborough
Ontario M1B 5N7
Tel.: +1 416 282 46 08
Fax: +1 416 282 30 39
E-Mail: sales@stauffcanada.com
www.stauffcanada.com

United States

STAUFF Corporation
7 Wm. Demarest Place
Waldwick, 07463-1542
New Jersey
Tel.: +1 201 444 78 00
Fax: +1 201 444 78 52
E-Mail: sales@stauffusa.com
www.stauffusa.com

Further branch office in
Canton, Michigan.

South America

Brazil

STAUFF Brasil Ltda.
Avenida Gupê 10767
Galpão 2 - Bloco A
Barueri, São Paulo, CEP 06422-120
Tel.: +55 11 47 72 72 00
Fax: +55 11 47 72 72 10
E-Mail: stauff@stauffbrasil.com
www.stauffbrasil.com



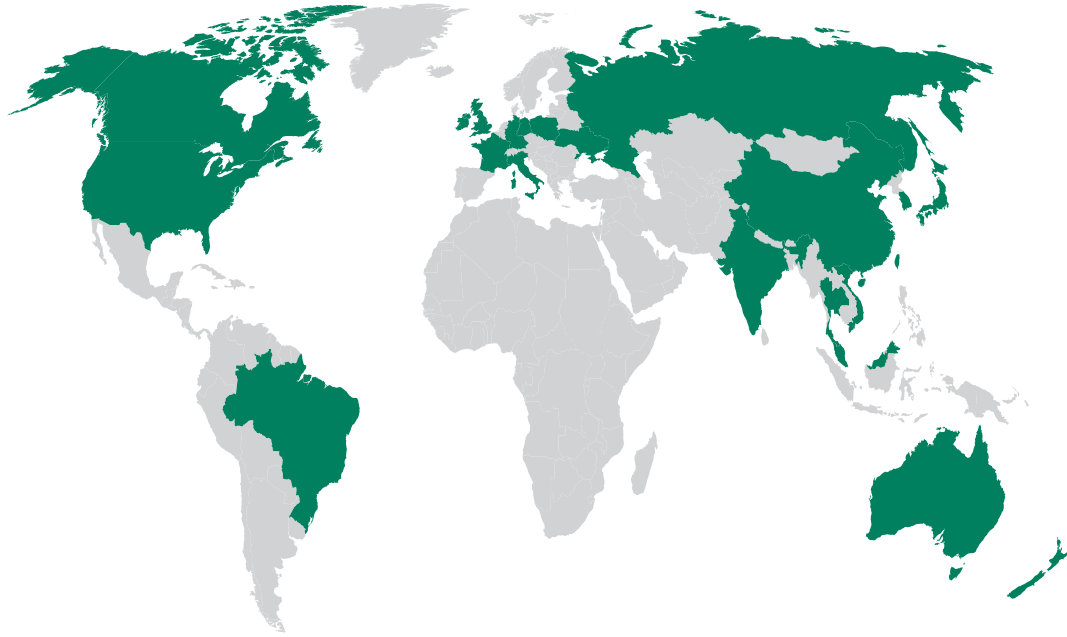

Asia

China

STAUFF CHINA

Building 1, No. 128, Die Qiao Road
Jushuo Industrial Zone, Kang Qiao
Shanghai, 201319
Tel.: +86 21 68 18 70 00
Fax: +86 21 68 18 71 36
E-Mail: info@stauff.com.cn
www.stauff.com.cn

Further branch offices in Beijing,
Changsha, Chengdu, Changchun,
Chongqing, Jinan, Harbin, Guangzhou,
Shenyang, Wuhan, Xian and Xuzhou.

India

STAUFF India Pvt. Ltd.

Gat no. 26/1 & 27, Sanghar Warehousing
Pune - Nagar Road
Lonikand - 412216
Tel.: +91 20 6731 4900
Fax: +91 20 6731 4905
E-Mail: sales@stauffindia.com
www.stauffindia.com

Korea

STAUFF Korea Ltd.

105, Hwajeonsandan 5-ro
Gangseo-gu
Busan, 46739
Tel.: +82 51 266 6666
Fax: +82 51 266 8866
E-Mail: info@stauff.co.kr
www.stauff.co.kr

Malaysia

STAUFF South East Asia Sdn Bhd

No. 8, Jalan SS13/6A
Subang Jaya Industrial Estate
47500 Subang Jaya
Tel.: +60 3 5637 78 88
Fax: +60 3 5636 78 90
E-Mail: sales@stauff.com.my
www.stauff.com.my

Thailand

STAUFF (Thailand) Co., Ltd.

10 Soi On-Nut 74/4
Pravet District
Bangkok 10250
Tel.: +66 2 721 73 23 / 24
Fax: +66 2 721 73 35
E-Mail: sales@stauff.co.th
www.stauff.co.th

Vietnam

STAUFF Vietnam Ltd.

2nd Floor, CT-IN Building
#435 Hoang Van Thu Street
Tan Binh District, Ho Chi Minh City
Tel.: +84 8 3948 10 41 / 42
Fax: +84 8 3948 10 44
E-Mail: sales@stauff.com.vn
www.stauff.com.vn

Oceania

Australia

STAUFF Corporation Pty Ltd

24-26 Doyle Avenue
Unanderra NSW 2526
Tel.: +61 2 4271 9000
Fax: +61 2 4271 8432
E-Mail: sales@stauff.com.au
www.stauff.com.au

Further branch offices in
Adelaide, Brisbane, Melbourne
and Sydney.

New Zealand

STAUFF Corporation (NZ) Ltd.

Unit D, 103 Harris Road
East Tamaki, Auckland 2013
Tel.: +64 9 912 1530
Fax: +64 9 912 1531
E-Mail: sales@stauff.co.nz
www.stauff.co.nz



Introduction

Overview

Push-to-Connect Couplings • FF/FU Series

Push-to-Connect Couplings • FH Series

Push-to-Connect Couplings • FO Series

Push-to-Connect Couplings • HP/HU Series

Push-to-Connect Couplings • UX Series

Push-to-Connect Couplings • IA Series

Push-to-Connect Couplings • IB Series

Push-to-Connect Couplings • ID Series

Push-to-Connect Couplings • BP Series

Push-to-Connect Couplings • HC Series

Push-to-Connect Couplings • HD Series

Push-to-Connect Couplings • HUS Series

Multi Couplings • MK Series

Screw-to-Connect Couplings • HS Series

Screw-to-Connect Couplings • PS Series

Screw-to-Connect Couplings • RH/RK Series

Screw-to-Connect Couplings • FT Series

Screw-to-Connect Couplings • HR Series

Screw-to-Connect Couplings • HH Series

Screw-to-Connect Couplings • HI Series

Screw-to-Connect Couplings • HT Series

Screw-to-Connect Couplings • HM Series

Screw-to-Connect Couplings • HV Series

Special Applications

Spare Parts / Accessories

Technical Appendix

Appendix



Catalogue 5

STAUFF Quick Release Couplings

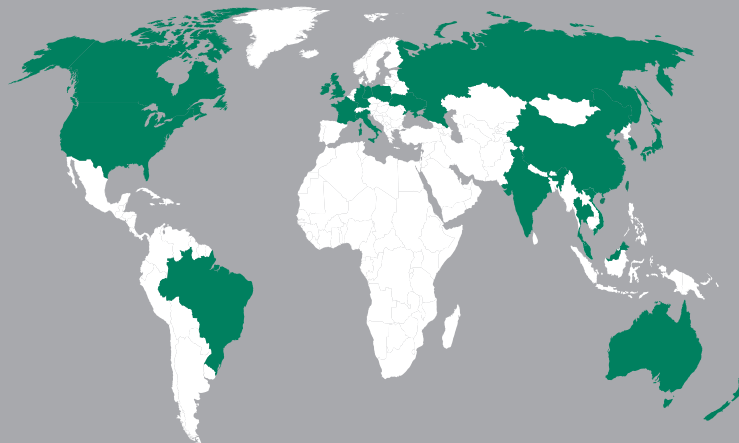

Germany

Walter Stauffenberg GmbH & Co. KG
Im Ehrenfeld 4
58791 Werdohl
Tel.: +49 2392 91 60
Fax: +49 2392 91 61 03
E-Mail: sales@stauff.com

STAUFF products and services are globally available through wholly-owned subsidiaries and a tight network of authorised distributors and representatives in all major industrial regions of the world.

You can find detailed contact information on the last two pages of this product catalogue or at

www.stauff.com